

# NOTICE

The information contained is for **DEALER REFERENCE PURPOSES ONLY**.  
MANUALS ARE MODEL AND SERIAL NUMBER SPECIFIC.

If additional printed manuals are required for your shop/office location, order by part number through the factory's Parts Center.

If a retail customer needs replacement manual(s) for a specific unit, contact the factory's Customer Data Center at: 800-829-0051 or  
[customerdata@vermeer.com](mailto:customerdata@vermeer.com)

This page intentionally left blank.

# *D36x50 Series II Navigator® Horizontal Directional Drill*

---

## *Parts Manual*



P4.03  
Serial No. 552 -  
Order No. 105400ZQT

# **Vermeer®**

## HOW TO USE THE MANUAL

This manual contains illustrations and parts lists of components and assemblies which make up the machine. Each page consists of the name of the assembly or component, a figure number, reference numbers, part numbers, part names, and the quantities of the parts used.

Assembly or component name helps identify the illustration and parts list for each figure. This name also helps locate the general area of the machine where the assembly or component can be located.

Figure numbers are used to identify each assembly or component and to group these assemblies or components into major categories.

Reference numbers shown in a column refer to the numbered parts in the illustration. This ties the part in the illustration to the part number and description in the parts list.

An asterisk indicates information about the item has changed since the previous release of the parts manual. A note in the Remarks column often explains the change.

Part numbers are used to identify individual parts or part assemblies.

Part descriptions provide the name of the part, plus additional information such as dimensional specifications and what parts are grouped together to form part assemblies, which helps you identify the part(s).

Quantities listed for each figure are only for that assembly or component and not the total used per machine.

This parts manual is not intended to be a complete guide for machine service or repairs. Contact your Vermeer dealer for any of your service or technical requirements.

## ORDERING PARTS

Parts for repair or replacement are available through our network of authorized dealers located throughout the world.

Use only authorized Vermeer parts for repair or replacement. Always give the serial number and

model number of the machine for which parts are being ordered. When ordering parts for component(s), which are not manufactured by Vermeer Corporation, also give the serial number of that component(s). Order all parts by part number, part name, and quantity needed.

## UPDATING AND REORDERING MANUALS

The parts lists, illustrations, and specifications in this manual are based on the latest information available at time of publication. Your machine may have product improvements and options not yet contained in this manual.

Vermeer Corporation reserves the right to make changes at any time without notice or obligation to you.

Your dealer will receive notice of these changes and can assist you with accurate parts identification when ordering.

A copy of this manual is supplied with each machine. Additional copies are available through your dealer. When ordering additional manuals, use the reorder number listed on the front cover and the quantity needed.

**NOTICE TO OWNER** – You are requested to notify Vermeer Corporation when you have purchased a **used** Vermeer machine. Notify the Customer Data Department by telephone: 800-829-0051 or 641-628-3141; email: [customerdata@vermeer.com](mailto:customerdata@vermeer.com); internet: [www.vermeer.com](http://www.vermeer.com) or [www.vermeerag.com](http://www.vermeerag.com); or, letter: Customer Data Dept., Vermeer Corporation, PO Box 200, Pella IA 50219 USA. Upon request, an owner of a used Vermeer machine will receive one free set of Operator's, Maintenance and Parts manuals.

**Maintenance Items - Section 1**

Hydraulic Supplies . . . . . Fig 1-1  
 Lubricants . . . . . Fig 1-2  
 DRC Series Connectors . . . . . Fig 1-3  
 DT Series Connectors . . . . . Fig 1-4  
 DTHD Series/HDFB Modules . . . . . Fig 1-5  
 DT Series Diode/Buss Blocks . . . . . Fig 1-6

**Decals/Resource Library - Section 2**

Cosmetic . . . . . Fig 2-1  
 Control . . . . . Fig 2-2  
 Control . . . . . Fig 2-3  
 Safety . . . . . Fig 2-4  
 Safety . . . . . Fig 2-5  
 Safety . . . . . Fig 2-6  
 Safety . . . . . Fig 2-7  
 Miscellaneous . . . . . Fig 2-8  
 Miscellaneous . . . . . Fig 2-9  
 Miscellaneous . . . . . Fig 2-10  
 Resource Library . . . . . Fig 2-11

**Frame - Section 3**

Main Frame/Track . . . . . Fig 3-1  
 Track Drive Motor . . . . . Fig 3-2  
 Components-Planetary . . . . . Fig 3-2z01  
 Components-Track Drive Park Brake . . . . . Fig 3-2z02  
 Components-Track Drive Motor . . . . . Fig 3-2z03  
 Track Tightener . . . . . Fig 3-3  
 Steel/Rubber Tracks (S/N 580-) . . . . . Fig 3-4r01  
 Steel/Rubber Tracks (S/N 552-579) . . . . . Fig 3-4  
 Rack-15' . . . . . Fig 3-5  
 Rack-10' . . . . . Fig 3-6  
 Rack-Lift Cylinder . . . . . Fig 3-7  
 Components-Rack Lift Cylinder . . . . . Fig 3-7z01  
 Carriage . . . . . Fig 3-8  
 Thrust-Motor . . . . . Fig 3-9  
 Components-Thrust Motor/W Brake . . . . . Fig 3-9z01  
 Components-Thrust Motor . . . . . Fig 3-9z02  
 Thrust-Valve . . . . . Fig 3-10  
 Components-Thrust Valve . . . . . Fig 3-10z01  
 Gearbox . . . . . Fig 3-11  
 Rotation-Motor . . . . . Fig 3-12  
 Components-Rotation Motor . . . . . Fig 3-12z01  
 Components-Rotation Motor . . . . . Fig 3-12z02  
 Drive Chuck . . . . . Fig 3-12x01  
 Components-Drive Chuck . . . . . Fig 3-12x01z01  
 Operator Platform . . . . . Fig 3-13

Control Console . . . . . Fig 3-14  
 Seat/Arm Rest . . . . . Fig 3-15  
 Outrigger . . . . . Fig 3-16  
 Outrigger Cylinder . . . . . Fig 3-17  
 Components-Outrigger Cylinder . . . . . Fig 3-17z01  
 Outrigger Valve . . . . . Fig 3-18  
 Components-Outrigger Valve . . . . . Fig 3-18z01  
 Umbrella . . . . . Fig 3-19

**Cab - Section 4**

Platform . . . . . Fig 4-1  
 Control Console . . . . . Fig 4-2  
 Seat . . . . . Fig 4-3  
 Cab Side-Right . . . . . Fig 4-4  
 Components-Cab Side-Right . . . . . Fig 4-4z01  
 Cab Side-Left . . . . . Fig 4-5  
 Components-Cab Side-Left . . . . . Fig 4-5z01  
 Windows . . . . . Fig 4-6  
 Door . . . . . Fig 4-7  
 Control Panel/Upper RH W/Cab . . . . . Fig 4-8  
 Control Panel-LH . . . . . Fig 4-9  
 Joystick Panel-LH . . . . . Fig 4-10  
 Components-Joystick . . . . . Fig 4-10z01  
 Joystick Panel-RH . . . . . Fig 4-11  
 Components-Joystick . . . . . Fig 4-11z01  
 Battery . . . . . Fig 4-12  
 Swing Cylinder/Valve . . . . . Fig 4-13  
 Components-Swing Cylinder . . . . . Fig 4-13z01  
 Blower/Duct . . . . . Fig 4-14  
 Rear Transport Station . . . . . Fig 4-15  
 Row Selector Control Box . . . . . Fig 4-16  
 Hood (S/N 582-) . . . . . Fig 4-17r01  
 Hood (S/N 552-581) . . . . . Fig 4-17  
 Kit-Headliner Panel . . . . . Fig 4-18  
 Harness-Keyswitch/Ground Lead . . . . . Fig 4-19  
 Harness-Outrigger Fuel . . . . . Fig 4-20  
 Harness-Heat A/C . . . . . Fig 4-21  
 Harness-Console . . . . . Fig 4-22  
 Harness-Engine Bay . . . . . Fig 4-23  
 Harness-Power Distribution . . . . . Fig 4-24  
 Harness-Cab Swing / 24 Way Extention . . . . . Fig 4-25  
 Heater Plumbing . . . . . Fig 4-26  
 Blower Electrical . . . . . Fig 4-27  
 A/C Condenser . . . . . Fig 4-28  
 A/C Compressor . . . . . Fig 4-29

**Engine - Section 5**

Engine/Mounting . . . . . Fig 5-1  
 Components-Engine . . . . . Fig 5-1z01  
 Components-Engine . . . . . Fig 5-1z02  
 Cooler Shroud . . . . . Fig 5-2

Radiator/Charge Air Cooler . . . . .	Fig 5-3
Components-Radiator . . . . .	Fig 5-3z01
Air Cleaner . . . . .	Fig 5-4
Components-Air Cleaner . . . . .	Fig 5-4z01
Exhaust . . . . .	Fig 5-5
Fuel & Antifreeze Tank . . . . .	Fig 5-6
Hood . . . . .	Fig 5-7
Hood Latch . . . . .	Fig 5-8
Hood Pivot. . . . .	Fig 5-9
Ether Start System (Optional). . . . .	Fig 5-10

## Hydraulic - Section 6

Oil Tank . . . . .	Fig 6-1
Oil tank-Cover 10" . . . . .	Fig 6-1z01
Oil Tank-Cover 6" . . . . .	Fig 6-1z02
Return Filter Manifold . . . . .	Fig 6-2
Components-Filter Head . . . . .	Fig 6-2z01
Stack Pump. . . . .	Fig 6-3
Components-90 Series 55cc . . . . .	Fig 6-3z01
Components-PFC/Implement. . . . .	Fig 6-3z02
Valve-Proportional/Dump . . . . .	Fig 6-4
Components-Valve Proportional/Dump. . . . .	Fig 6-4z01
Valve-Torque/Thrust Limiter. . . . .	Fig 6-5
Components-Torque . . . . .	Fig 6-5z01
Valve-Return. . . . .	Fig 6-6
Components-Valve Return. . . . .	Fig 6-6z01
Valve-Remote Lockout . . . . .	Fig 6-7
Components-Valve Remote Lockout . . . . .	Fig 6-7z01
Cylinder-Gearbox Lock. . . . .	Fig 6-8
Components-Cylinder Gearbox Lock. . . . .	Fig 6-8z01
Valve-Pressure Gauge Shuttle. . . . .	Fig 6-9
Valve-3 Speed Gearbox . . . . .	Fig 6-10
Components-Valve 3 Speed Gearbox. . . . .	Fig 6-10z01
Hose Carrier & Tower (10') . . . . .	Fig 6-11
Components-Hose Track (10') . . . . .	Fig 6-11z01
Hose Carrier & Tower (15') . . . . .	Fig 6-12
Components-Hose Track (15') . . . . .	Fig 6-12z01
Carriage Bulkhead Fittings. . . . .	Fig 6-13
Oil Cooler . . . . .	Fig 6-14
Block-Transducer . . . . .	Fig 6-15
Transport Valve 10' . . . . .	Fig 6-16
Components-Control Valve . . . . .	Fig 6-16z01
Components-WH Main Relief . . . . .	Fig 6-16z02
Components-Standard Spool Positioner . . . . .	Fig 6-16z03
Components-Load Check Plug. . . . .	Fig 6-16z04
Valve-Counter Balance . . . . .	Fig 6-17
Components-Valve Counter Balance. . . . .	Fig 6-17z01

## Vise - Section 7

Vise Clamp . . . . .	Fig 7-1
Cylinder-Jaw. . . . .	Fig 7-2

Components-Cylinder Jaw . . . . . Fig 7-2z01  
 Cylinder-Rotation . . . . . Fig 7-3  
 Components-Cylinder Rotation . . . . . Fig 7-3z01  
 Valve-Vise Clamp . . . . . Fig 7-4  
 Components-Valve Vise Clamp . . . . . Fig 7-4z01  
 Strike Alert (S/N 568-) . . . . . Fig 7-5r01  
 Strike Alert (S/N 552-567) . . . . . Fig 7-5  
 Tubing Tong . . . . . Fig 7-6  
 Components-Tubing Tong . . . . . Fig 7-6z01  
 Components-Tubing Tong Cylinder. . . . . Fig 7-6z02  
 Auto Greaser. . . . . Fig 7-7  
 Components-Auto Greaser Cylinder . . . . . Fig 7-7z01  
 Components-Auto Greaser Valve . . . . . Fig 7-7z02  
 Bucket Auto Greaser Mount . . . . . Fig 7-8  
 Bucket Auto Greaser (1 Gal.) . . . . . Fig 7-9  
 Bucket Auto Greaser Valve . . . . . Fig 7-10  
 Bucket Auto Greaser Cylinder. . . . . Fig 7-11  
 Components-Bucket Auto Greaser Cylinder. . . . . Fig 7-11z01  
 Bucket Auto Greaser Follower (1 Gal.) . . . . . Fig 7-12  
 Stakedown (S/N 566-) . . . . . Fig 7-13r01  
 Stakedown (S/N 552-565) . . . . . Fig 7-13  
 Components- Motor . . . . . Fig 7-13z01  
 Components- Cylinder . . . . . Fig 7-13z02  
 Valve-Stakedown . . . . . Fig 7-14  
 Components-Valve . . . . . Fig 7-14z01  
 Vise Dies/Rod Wipers . . . . . Fig 7-15

**Rod Loader - Section 8**

Motor-10' Rod Loader . . . . . Fig 8-1  
 Components-Motor Rod Loader . . . . . Fig 8-1z01  
 Motor-15' Rod Loader . . . . . Fig 8-2  
 Guard . . . . . Fig 8-3  
 Safety Arm . . . . . Fig 8-4  
 Extend/Retract Arm . . . . . Fig 8-5  
 Rod Selector . . . . . Fig 8-6  
 Rod Lift Cylinder . . . . . Fig 8-7  
 Components-Rod Lift Cylinder . . . . . Fig 8-7z01  
 Valve Rod Loader . . . . . Fig 8-8  
 Components-Valve . . . . . Fig 8-8z01  
 Row Selector . . . . . Fig 8-9  
 Row Selector Control Box. . . . . Fig 8-10  
 Rod Box-10' (250 FT.) . . . . . Fig 8-11  
 Rod Box-10' (500 FT.) . . . . . Fig 8-12  
 Rod Box-15' (300 FT.) . . . . . Fig 8-13  
 Rod Box-15' (600 FT.) . . . . . Fig 8-14

**Control & Electrical - Section 9**

Electrical-Operator Controls . . . . . Fig 9-1  
 Upper LH Panel . . . . . Fig 9-2  
 Left Joystick Panel . . . . . Fig 9-3  
 Upper RH Panel-Domestic . . . . . Fig 9-4



Upper RH Panel-International . . . . . Fig 9-5  
 Lower RH Panel . . . . . Fig 9-6  
 Accessory Panel . . . . . Fig 9-7  
 Right Joystick Panel. . . . . Fig 9-8  
 Battery . . . . . Fig 9-9  
 Engine Electrical Panel . . . . . Fig 9-10  
 Work Light . . . . . Fig 9-11  
 Slowdown & Anticrash-10'. . . . . Fig 9-12  
 Slowdown & Anticrash-15'. . . . . Fig 9-13  
 Remote Lockout-International. . . . . Fig 9-14  
 Components-Remote Lockout-International. . . . . Fig 9-14z01  
 Remote Lockout-Domestic . . . . . Fig 9-15  
 Controller W/Hardware . . . . . Fig 9-16  
 Rod Loader Switches . . . . . Fig 9-17  
 Mount W/PPU. . . . . Fig 9-18  
 Harness-Deere 4045H HP . . . . . Fig 9-19  
 Harness-Rotation Gearbox. . . . . Fig 9-20  
 Harness-Engine Bay. . . . . Fig 9-21  
 Harness-Thrust, Slowdown, Stop, Crash-10' . . . . . Fig 9-22  
 Harness-Thrust, Slowdown, Stop, Crash-15' . . . . . Fig 9-23  
 Harness-Outrigger, Fuel, H2O, Rod Loader. . . . . Fig 9-24  
 Harness-stakedown, Vise, Grease, Lights. . . . . Fig 9-25  
 Harness-Console D24/D36 . . . . . Fig 9-26  
 Harness-Strike Alert . . . . . Fig 9-27  
 Harness-Hose Track/Strike Alert . . . . . Fig 9-28  
 Harness-Start Relay, Power . . . . . Fig 9-29  
 Harness-Main Power . . . . . Fig 9-30  
 Harness-Ground Lead . . . . . Fig 9-31  
 Harness-Remote Lockout. . . . . Fig 9-32  
 Harness-Jumper . . . . . Fig 9-33  
 Harness-Thrust/Rotation Pressure Sensor . . . . . Fig 9-34  
 Harness-Rotation/Thrust EDC . . . . . Fig 9-35  
 Harness-Mud Pump (PPU) . . . . . Fig 9-36  
 Harness-Mud Pump (PWM). . . . . Fig 9-37  
 Harness-Rotation (PPU) . . . . . Fig 9-38  
 Harness-Controller. . . . . Fig 9-39  
 Harness-LH Console. . . . . Fig 9-40  
 Harness-Rotation Limiter Relay . . . . . Fig 9-41  
 Harness-Power Distribution . . . . . Fig 9-42  
 Power Relay . . . . . Fig 9-43  
 Harness-Vise Check Valve. . . . . Fig 9-44  
 Harness-Neutral Ground Jumper . . . . . Fig 9-45

**Ground & Safety - Section 10**

Voltage Stake . . . . . Fig 10-1  
 Components-Voltage Stake . . . . . Fig 10-2  
 Components-Voltage Stake . . . . . Fig 10-3  
 Safety Features. . . . . Fig 10-4

**Water Pump - Section 11**

Water Pump-50 GPM FMC ..... Fig 11-1  
 Components-50 GPM FMC ..... Fig 11-1z01  
 Components-Pressure Dumbell Piston ..... Fig 11-1z02  
 Components-Ball Valve ..... Fig 11-1z03  
 Drive Motor-50 GPM FMC..... Fig 11-2  
 Components-Motor 50 GPM FMC..... Fig 11-2z01  
 Water Pump-50 GPM APLEX ..... Fig 11-3  
 Components-Crankshaft ..... Fig 11-3z01  
 Components-Power Frame..... Fig 11-3z02  
 Components-Fluid End ..... Fig 11-3z03  
 Components-Suction/Discharge Valve ..... Fig 11-3z04  
 Components-Piston..... Fig 11-3z05  
 Drive Motor-50 GPM APLEX..... Fig 11-4  
 Components-Motor 50 GPM APLEX..... Fig 11-4z01  
 Water Pump-70 GPM APLEX ..... Fig 11-5  
 Components-Crankshaft ..... Fig 11-5z01  
 Components-Power Frame..... Fig 11-5z02  
 Components-Fluid End ..... Fig 11-5z03  
 Components-Suction/Discharge Valve ..... Fig 11-5z04  
 Components-Piston..... Fig 11-5z05  
 Drive Motor-70 GPM APLEX..... Fig 11-6  
 Components-Motor 70 GPM APLEX..... Fig 11-6z01  
 Wash Wand..... Fig 11-7  
 Cylinder-Water Shut Off ..... Fig 11-8  
 Components-Cylinder..... Fig 11-8z01  
 Water Valve-15' ..... Fig 11-9  
 Two Speed Valve..... Fig 11-10  
 Water Valve-10' ..... Fig 11-11  
 Rockfire Fitting..... Fig 11-12  
 Components-Cap 2" ..... Fig 11-12z01

**Hose Diagrams - Section 12**

Rotation System ..... Fig 12-1  
 Thrust/Pullback ..... Fig 12-2  
 Implement System ..... Fig 12-3  
 Ground Drive System..... Fig 12-4  
 Stakedown..... Fig 12-5  
 Vise Clamp ..... Fig 12-6  
 Rod Loader ..... Fig 12-7  
 Water System-50 GPM FMC ..... Fig 12-8  
 Water System- 50 GPM Aplex..... Fig 12-9  
 Water System- 70 GPM Aplex..... Fig 12-10  
 Bucket Auto Greaser ..... Fig 12-11  
 Cab ..... Fig 12-12

This page intentionally left blank.

Hydraulic Supplies Fig 1-1

CORDURA SLEEVES

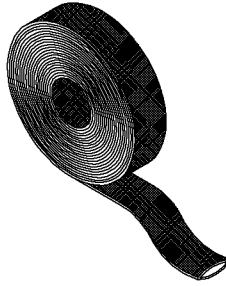

NOTE: SPECIFY LENGTH WHEN ORDERING

TIE STRAPS

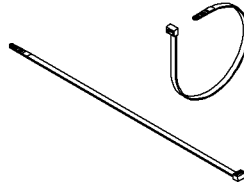

O-RINGS

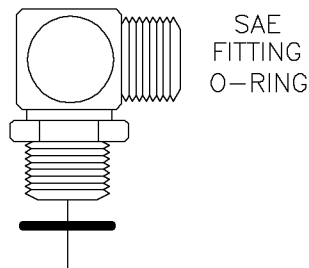

SAE  
FITTING  
O-RING

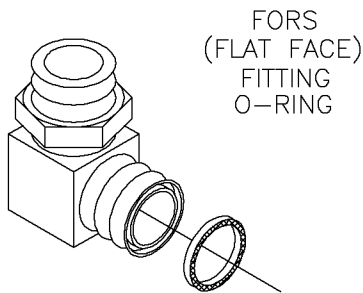

FORs  
(FLAT FACE)  
FITTING  
O-RING

NOTE: O-RINGS LISTED ARE 90 DUROMETER

## Hydraulic Supplies Fig 1-1

REF. NO.	*	PART NO.	DESCRIPTION	QTY.	REMARKS
			<b>CORDURA SLEEVES</b>		
		83726001	INSIDE DIAMETER .71		
		235824001	INSIDE DIAMETER .90		
		66094001	INSIDE DIAMETER 1.22		
		67264001	INSIDE DIAMETER 1.42		
		69129001	INSIDE DIAMETER 1.59		
		53840001	INSIDE DIAMETER 1.81		
		53841001	INSIDE DIAMETER 2.37		
		235824001	INSIDE DIAMETER 2.66		
			NOTE: SPECIFY LENGTH WHEN ORDERING		
			<b>TIE STRAPS</b>		
		78657001	4 IN. LENGTH		
		59634001	6 IN. LENGTH		
		59634001	8 IN. LENGTH		
		58151001	15 IN. LENGTH		
			<b>O-RINGS (SAE)</b>		
		78185027	4M SAE FITTING SIZE		
		53649081	5M SAE FITTING SIZE		
		59088057	6M SAE FITTING SIZE		
		59088053	8M SAE FITTING SIZE		
		792029	10M SAE FITTING SIZE		
		3152013	12M SAE FITTING SIZE		
		3155015	14M SAE FITTING SIZE		
		81580001	16M SAE FITTING SIZE		
		93316001	20M SAE FITTING SIZE		
			<b>O-RINGS (FORS)</b>		
		93843001	ORING-AS-011-C90 FOR#4ORS FIT		90 Durometer
		93844001	ORING-AS-012-C90 FOR #6ORS FIT		90 Durometer
		93845001	ORING-AS-014-C90 FOR#8ORS FIT.		90 Durometer
		93846001	O-RING-AS-016-C90 FOR#10ORS FIT		90 Durometer
		93847001	O-RING-AS-018-C90 FOR#12ORS FIT		90 Durometer
		93848001	ORING-AS-021-C90 FOR#16ORS FIT		90 Durometer
		93849001	O-RING-AS-025-C90 FOR#20ORS FIT		90 Durometer
		93850001	O-RING-AS-029-C90 FOR#24ORS FIT		90 Durometer

Lubricants Fig 1-2

MOTOR OIL, HYD FLUID, HYD OIL, TRANSMISSION FLUID, ETC.

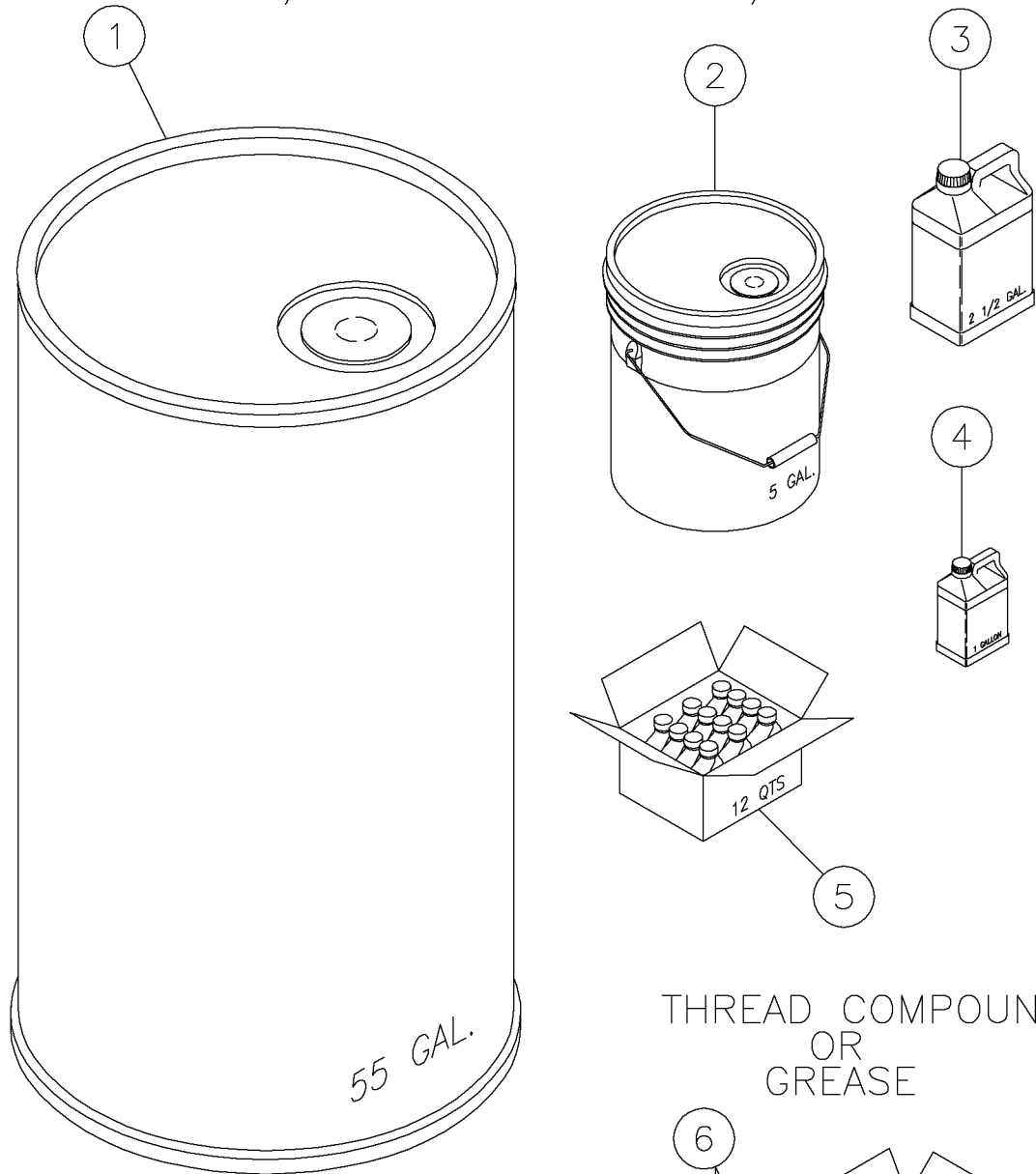

THREAD COMPOUND OR GREASE

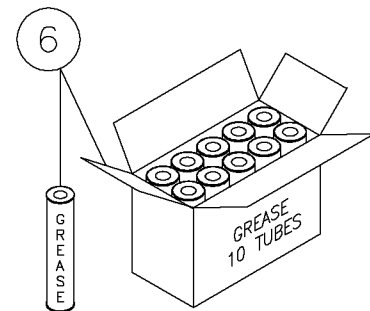

## Lubricants Fig 1-2

REF. NO.	*	PART NO.	DESCRIPTION	QTY.	REMARKS
			55 GALLON		
1		99661005	UL 15W40 55 GALLON DRUM		
1		104155005	UL 30W 55 GALLON DRUM		
1		99662005	UL VMF HYD FLUID 55 DRUM		
1		101518005	UL HY-POWER 68 55 GALLON DRUM		
1		101519005	UL HY-POWER 100 55 GALLON DRUM		
1		621584005	UL HY-POWER 46 HYD OIL 55 GAL.		
1		144569982	MOBIL EAL224H 55 GALLON DRUM		
1		99663005	UL 80/90WGEAR OIL 55 DRUM		
			5 GALLON		
2		99661003	UL 15W40 5 GALLON PAIL		
2		142939003	UL 10W/30 5 GAL PAIL		
2		99662003	UL VMF HYD FLUID 5 GALLON PAIL		
2		101518003	UL HY-POWER 68 5 GALLON PAIL		
2		101519003	UL HY-POWER 100 5 GALLON PAIL		
2		621584003	UL HY-POWER 46 HYD OIL 5 GALLON		
2		125653003	UL ATF 5 GALLON		
2		127732003	HYD. OIL-BIODEGRADABLE (5 GAL)		
2		99663003	UL 80W90 TRANS 5 GALLON PAIL		
			2 1/2 GALLON		
3		99661002	UL 15W40 CASE 2 2 1/2 GALLON JUGS		
3		99662002	UL VMF HYD 2 2 1/2 GALLON JUGS		
3		101518002	UL HY-POWER 68 2 2 1/2 GALLON JUGS		
3		101519002	UL HY-POWER 100 2 2 1/2 GALLON BUCKETS		
3		621584002	UL HY-POWER 46 HYD OIL 2 1/2 GAL (CASE 2)		
3		125653002	UL ATF FLUID 2 2 1/2 GALLON JUGS		
3		99663002	UL 80W90 TRANS 2 1/2 case		
3		142939002	ULTRA GOLD 10W30 2 2 1/2 GALLON BUCKETS		
			1 GALLON		
4		101518007	*UL HY-POWER 68 BULK 12 QUARTS (CASE)		
5		99661008	UL 15W40 CASE 12 QUARTS		
5		142939008	UL 10W30 MOTOR OIL(12 QTS)		
5		247337008	50W OIL-NONDETERGENT(CASE 12 QUARTS)		
5		216825008	UL 75W90 SYNTHETIC 12 QUARTS		
5		238858008	PL VMR ISO SYN GEAR 12QT/CS 10pc CASE (14oz TUBES)		
6		101562003	UL ULTRA LC GREASE CASE OF 10 14OZ		
6		296262012	THRD CMPND-PLUSCO 135-SINGLE CARTRIDGE		
6		275927982	THRD CMPND - PLUSCO 135 - 10 PACK		
6		275928982	THRD CMPND - CASE OF 4 / 10 PACKS		

DRC Series Connectors Fig 1-3

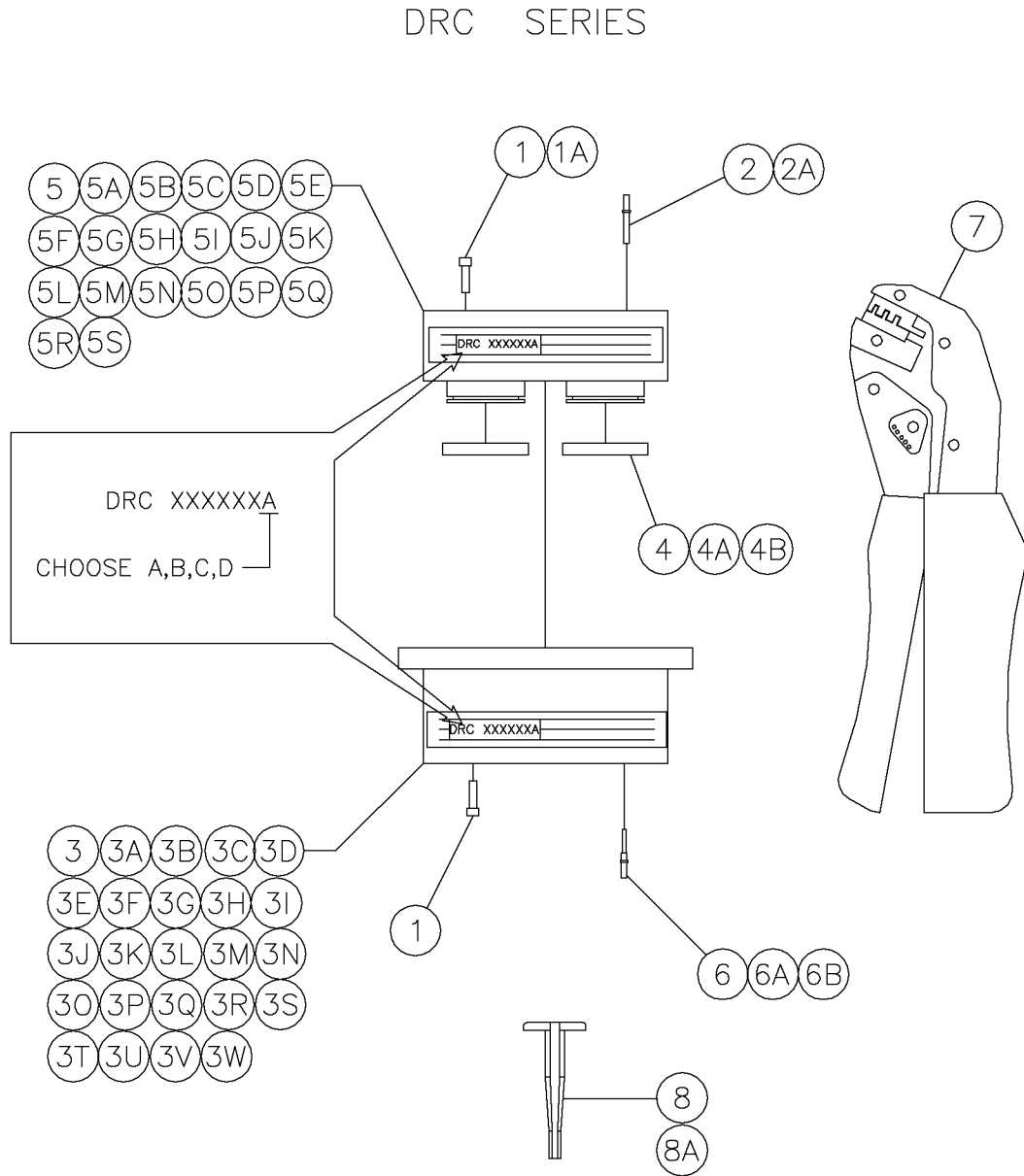



## DRC Series Connectors Fig 1-3

REF. NO.	*	PART NO.	DESCRIPTION	QTY.	REMARKS
1		276906001	PLUG - SEALING (20)		
1A		94201001	PLUG - SEALING (12-16)		
2		91354001	SOCKET - 16/18 GA.		
2A		276916001	SOCKET - 20 GA.		
3		276894001	RECEPTACLE - 24 PIN INLINE (A)		
3A		276907001	RECEPTACLE - 24 PIN INLINE (B)		
3B		276917001	RECEPTACLE - 24 PIN INLINE (C)		
3C		276918001	RECEPTACLE - 24 PIN INLINE (D)		
3D		276895001	RECEPTACLE - 24 IN FLNG MNT (A)		
3E		276908001	RECEPTACLE - 24 PIN FLNG MNT (B)		
3F		276919001	RECEPTACLE - 24 PIN FLNG MNT (C)		
3G		276920001	RECEPTACLE - 24 PIN FLNG MNT (D)		
3H		276896001	RECEPTACLE - 40 PIN INLINE (A)		
3I		276909001	RECEPTACLE - 40 PIN INLINE (B)		
3J		276921001	RECEPTACLE - 40 PIN INLINE (C)		
3K		276922001	RECEPTACLE - 40 PIN INLINE (D)		
3L		276897001	RECEPTACLE - 40 PIN FLNG MNT (A)		
3M		276910001	RECEPTACLE - 40 PIN FLNG MNT (B)		
3N		276923001	RECEPTACLE - 40 PIN FLNG MNT (C)		
3O		276924001	RECEPTACLE - 40 PIN FLNG MNT (D)		
3P		276898001	RECEPTACLE - 70 PIN INLINE (A)		
3Q		276911001	*RECEPTACLE - 70 PIN INLINE (B)		
3R		276925001	RECEPTACLE - 70 PIN INLINE (C)		
3S		276926001	RECEPTACLE - 70 PIN INLINE (D)		
3T		276899001	RECEPTACLE - 70 PIN FLNG MNT (A)		
3U		276912001	RECEPTACLE - 70 PIN FLNG MNT (B)		
3V		276927001	RECEPTACLE - 70 PIN FLNG MNT (C)		
3W		276928001	RECEPTACLE - 70 PIN FLNG MNT (D)		
4		276900001	GASKET - 24 PIN INTERFACE		
4A		276901001	GASKET - 40 PIN INTERFACE		
4B		276902001	GASKET - 70 PIN INTERFACE		
5		276931001	PLUG - 24 PIN (SIZE 20 CONTACTS) (A)		
5A		276932001	PLUG - 24 PIN (SIZE 20 CONTACTS)		
5B		276933001	PLUG - 24 PIN (SIZE 20 CONTACTS) (C)		
5C		276934001	PLUG - 24 PIN (SIZE 20 CONTACTS) (D)		
5D		276939001	PLUG - 40 PIN (SIZE 20 CONTACTS) (A)		
5E		276940001	PLUG - 40 PIN (SIZE 20 CONTACTS) (B)		
5F		276941001	PLUG - 40 PIN (SIZE 20 CONTACTS) (C)		
5G		276942001	PLUG - 40 PIN (SIZE 20 CONTACTS) (D)		
5H		276903001	PLUG - 24 PIN (A)		
5I		276913001	PLUG - 24 PIN (B)		
5J		276929001	PLUG - 24 PIN (C)		
5K		276930001	PLUG - 24 PIN (D)		
5L		276904001	PLUG - 40 PIN (A)		
5M		276914001	PLUG - 40 PIN (B)		
5N		276935001	PLUG - 40 PIN (C)		
5O		276936001	PLUG - 40 PIN (D)		
5P		276905001	PLUG - 70 PIN (A)		
5Q		276915001	PLUG - 70 PIN (B)		
5R		276937001	PLUG - 70 PIN (C)		
5S		276938001	PLUG - 70 PIN (D)		
6		276866001	PIN - 14/16 GA.		
6A		87696001	PIN-16/18 GA.		
6B		276951001	PIN - (20 GA.)		
7		286553001	TOOL - DEUTSCH CRIMPING (FIELD)		
8		276892001	TOOL - 16/18 GA. EXTRACTOR (BLUE)		
8A		276893001	TOOL - 20/24 GA. EXTRACTOR (RED)		

DT Series Connectors Fig 1-4

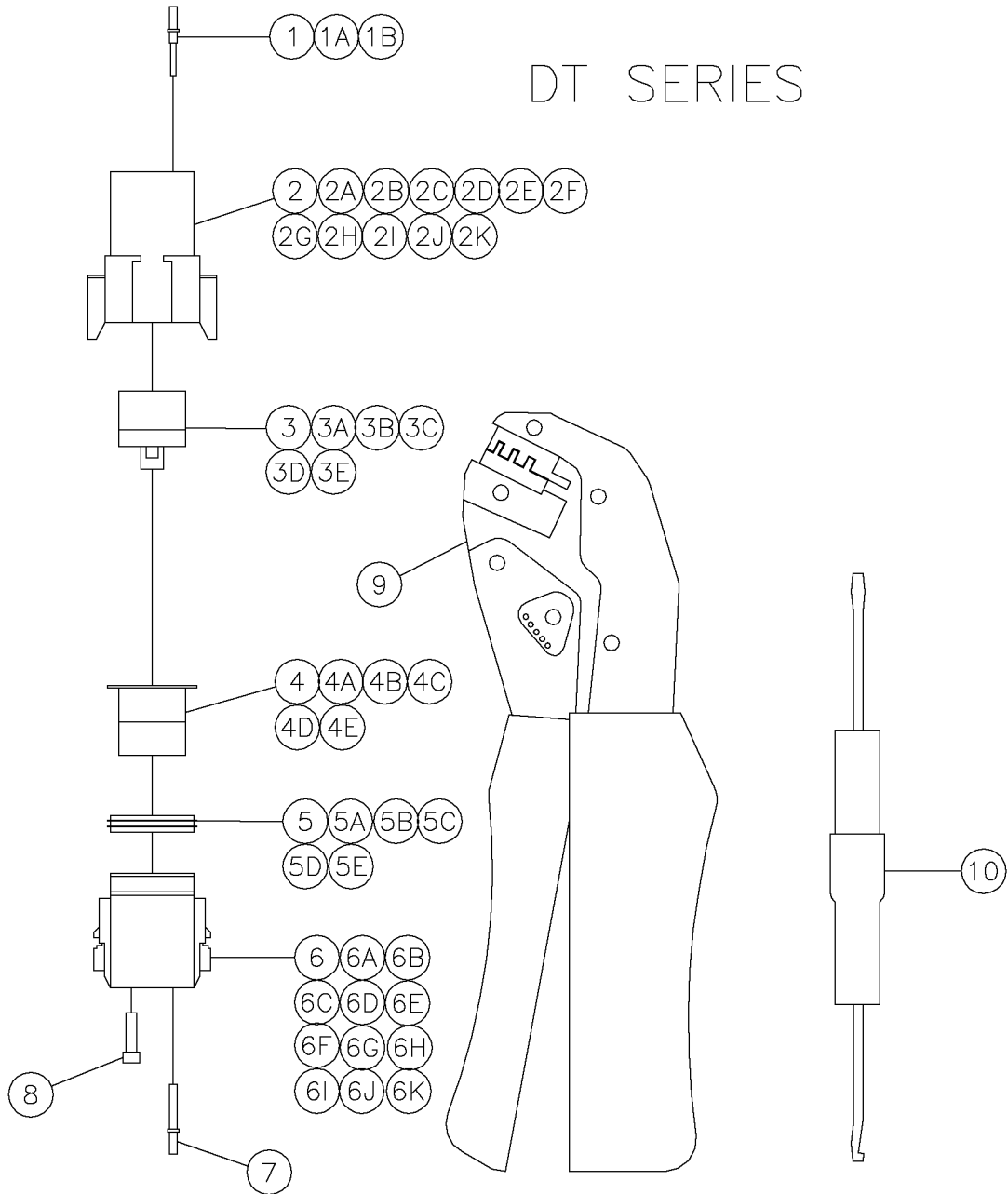

## DT Series Connectors Fig 1-4

REF. NO.	*	PART NO.	DESCRIPTION	QTY.	REMARKS
1		276866001	PIN - 14/16 GA.		
1A		87696001	PIN-16/18 GA.		
1B		276951001	PIN - (20 GA.)		
2		276867001	RECEPTACLE - 2 PIN		
2A		276868001	RECEPTACLE - 3 PIN		
2B		276869001	RECEPTACLE - 4 PIN		
2C		276890001	RECEPTACLE - 6 PIN		
2D		276943001	RECEPTACLE - 8 PIN (A)		
2E		276944001	RECEPTACLE - 8 PIN (B)		
2F		276945001	RECEPTACLE - 8 PIN (C)		
2G		276946001	RECEPTACLE - 8 PIN (D)		
2H		276947001	RECEPTACLE - 12 PIN (A)		
2I		276948001	RECEPTACLE - 12 PIN (B)		
2J		276949001	RECEPTACLE - 12 PIN (C)		
2K		276950001	RECEPTACLE - 12 PIN (D)		
3		276870001	WEDGE - 2 PIN RECEPTACLE		
3A		276871001	WEDGE - 3 PIN RECEPTACLE		
3B		276872001	WEDGE - 4 PIN RECEPTACLE		
3C		276873001	WEDGE - 6 PIN RECEPTACLE		
3D		94200001	WEDGE - 8 PIN RECEPTACLE		
3E		103213001	WEDGE - 12 PIN RECEPTACLE		
4		276874001	WEDGE - 2 PIN PLUG		
4A		276875001	WEDGE - 3 PIN PLUG		
4B		276876001	WEDGE - 4 PIN PLUG		
4C		276877001	WEDGE - 6 PIN PLUG		
4D		98106001	WEDGE - 8 PIN PLUG		
4E		103214001	WEDGE - 12 PIN PLUG		
5		276878001	GASKET - INTERFACE 2 PIN		
5A		276879001	GASKET - INTERFACE 3 PIN		
5B		276880001	GASKET - INTERFACE 4 PIN		
5C		276881001	GASKET - INTERFACE 6 PIN		
5D		276882001	GASKET - INTERFACE 8 PIN		
5E		276883001	GASKET - INTERFACE 12 PIN		
6		276884001	PLUG - 2 PIN		
6A		276885001	PLUG - 3 PIN		
6B		276886001	PLUG - 4 PIN		
6C		276887001	PLUG - 6 PIN		
6D		98107001	PLUG - 8 PIN (A)		
6E		276985001	PLUG - 8 PIN (B)		
6F		276986001	PLUG - 8 PIN (C)		
6G		276987001	PLUG - 8 PIN (D)		
6H		103211001	PLUG - 12 PIN (A)		
6I		276988001	PLUG - 12 PIN (B)		
6J		276989001	PLUG - 12 PIN (C)		
6K		276990001	PLUG - 12 PIN (D)		
7		91354001	SOCKET - 16/18 GA.		
8		94201001	PLUG - SEALING (12-16)		
9		286553001	TOOL - DEUTSCH CRIMPING (FIELD)		
10		286553003	TOOL - DEUTSCH (FIELD)		

DTHD Series/HDFB Modules Fig 1-5

DTHD SERIES

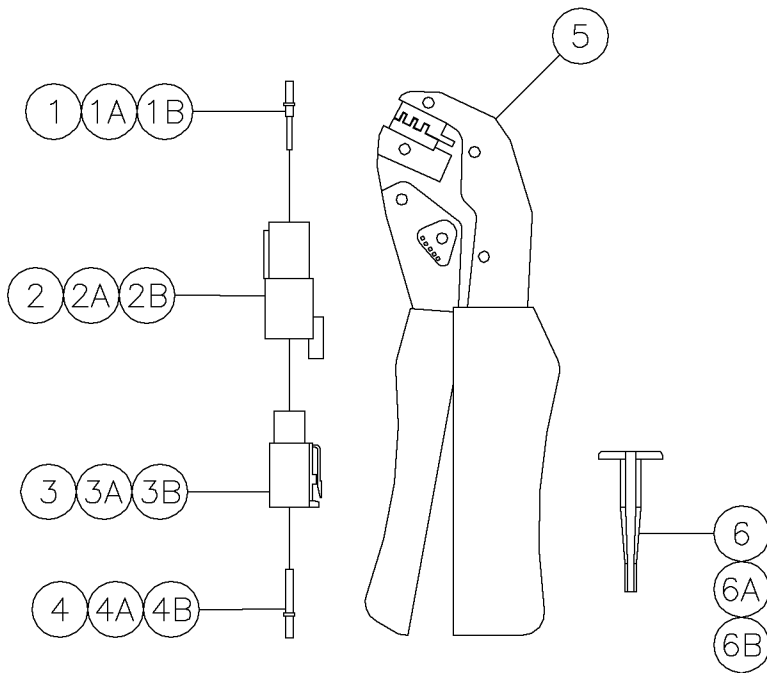

HDFB MODULES

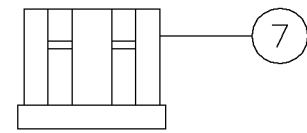

## DTHD Series/HDFB Modules Fig 1-5

REF. NO.	*	PART NO.	DESCRIPTION	QTY.	REMARKS
1		231988001	PIN-12 GA		
1A		276953001	PIN - 8/10 GA.		
1B		276954001	PIN - 6 GA.		
2		279423001	RECEPTACLE - SIZE 4 CONTACT		
2A		279424001	RECEPTACLE - SIZE 8 CONTACT		
2B		279425001	RECEPTACLE - SIZE 12 CONTACT		
3		279426001	PLUG - SIZE 4 CONTACT		
3A		279427001	PLUG - SIZE 8 CONTACT		
3B		279428001	PLUG - SIZE 12 CONTACT		
4		276982001	SOCKET - 12/14 GA. DEUTSCH		
4A		276984001	SOCKET - 8/12 GA.		
4B		276952001	SOCKET - 6 GA.		
5		603961001	PLIERS-DEUTSCH CRIMPING		
6		276981001	PLUG - 19 PIN (SHELL SIZE 24)		
6A		276889001	TOOL - 8/10 GA. EXTRACTOR (GREEN)		
6B		276888001	TOOL - 6 GA. EXTRACTOR (WHITE)		
7		279430001	MODULE - FEEDBACK (10 PIN)		
note			Not All Items Listed Are Used On This Machine		

DT Series Diode/Buss Blocks Fig 1-6

DT SERIES DIODE/BUSS BLOCKS

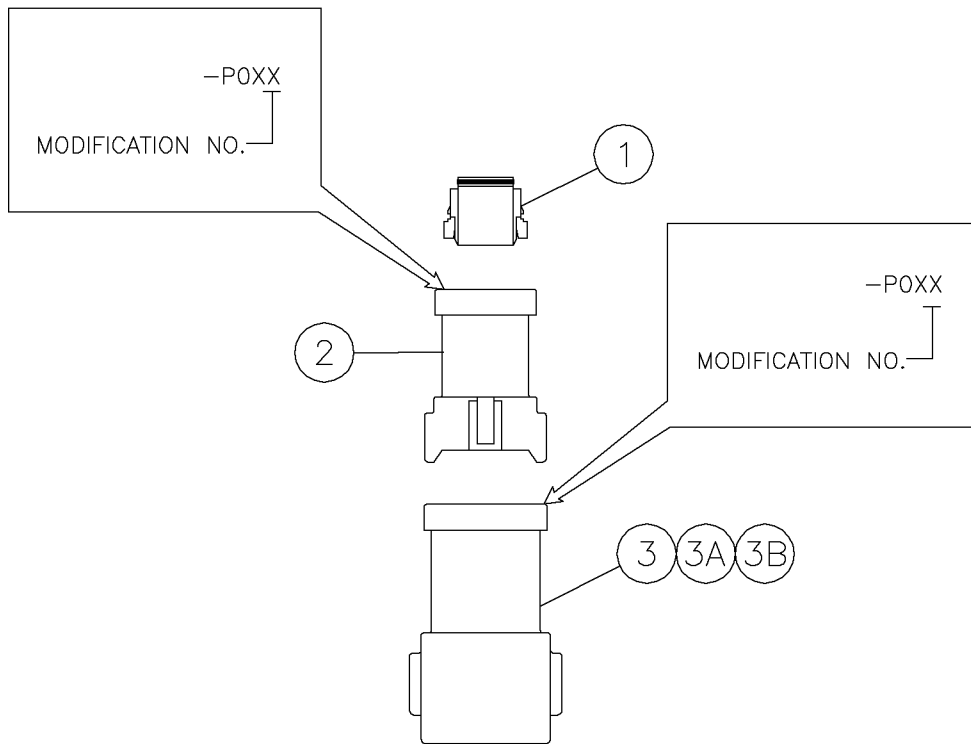

## DT Series Diode/Buss Blocks Fig 1-6

REF. NO.	*	PART NO.	DESCRIPTION	QTY.	REMARKS
1		282531001	MODULE - DEUTSCH DT06-6S 3AMP DIODE	1	
2		700000096	BUSS - 1 - 8PIN - B	1	
3		700000102	BUSS - 1 - 12PIN - B - NICKEL	1	
3A		700000104	BUSS - 2 - 12PIN - B - 6/6	1	
3B		700000106	BUSS - 4 - 12PIN - B - 3/3/3/3	1	

Cosmetic Fig 2-1

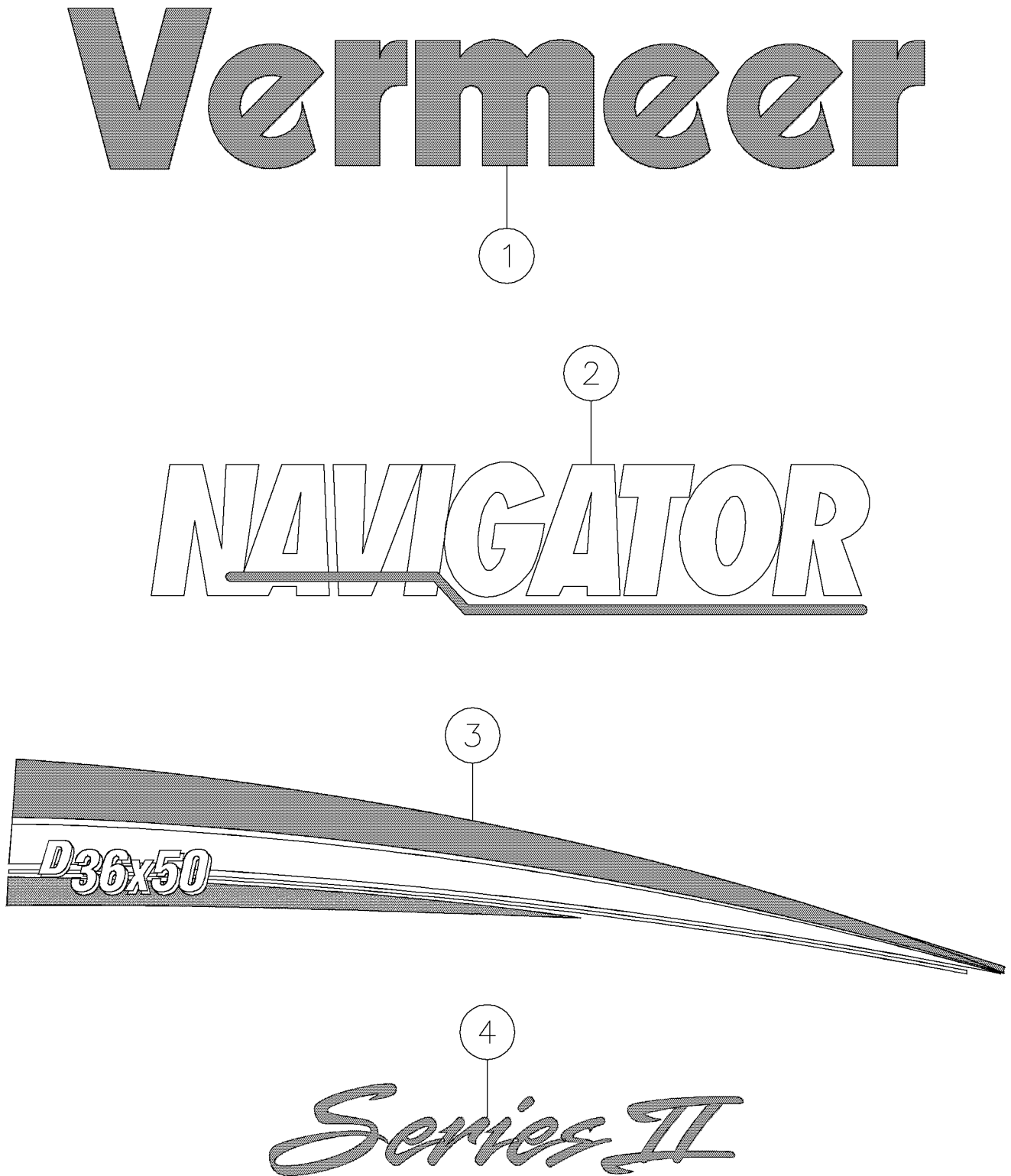



## Cosmetic Fig 2-1

REF. NO.	*	PART NO.	DESCRIPTION	QTY.	REMARKS
1		2326619	DECAL- VERMEER 3 X 15	1	
2		70000614	DECAL-MODEL NAVIGATOR (BIG)	1	
3		7000D176	DECAL D36X50II STRIPE	1	
4		7000C463	DECAL - SERIES II MEDIUM	1	

Control Fig 2-2

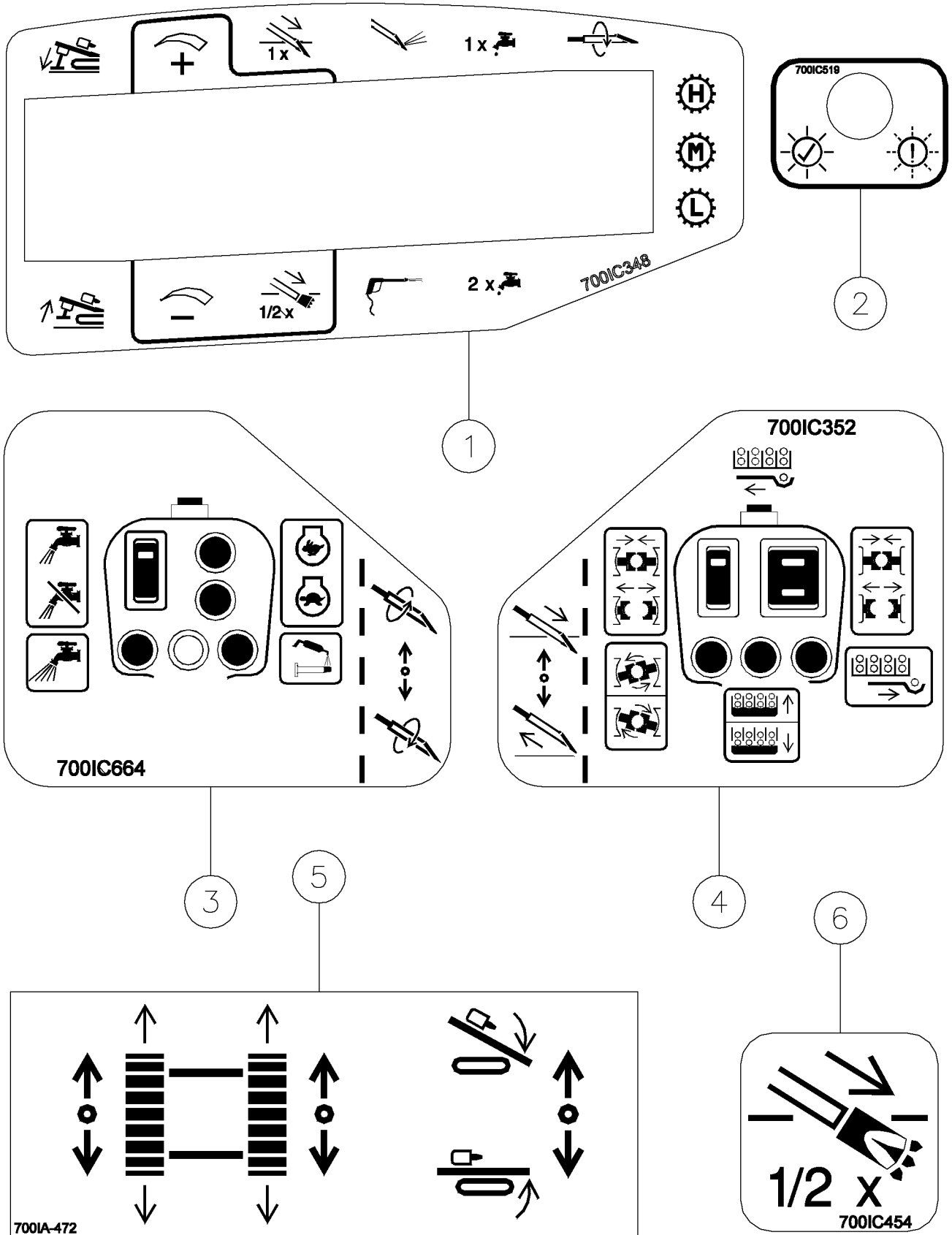

## Control Fig 2-2

REF. NO.	*	PART NO.	DESCRIPTION	QTY.	REMARKS
1		700IC348	DECAL - CONTROL LEFT HAND	1	
2		700IC519	DECAL - STRIKE ALERT GREEN LIGHT	1	
3		700IC664	DECAL - CONTROL LH JOYSTICK	1	
4		700IC352	DECAL - CONTROL RIGHT HAND JOYSTICK	1	
5		700IA472	DECAL-CTRL. TRACK & RACK (UG)	1	
6		700IC454	DECAL - CONTROL	1	



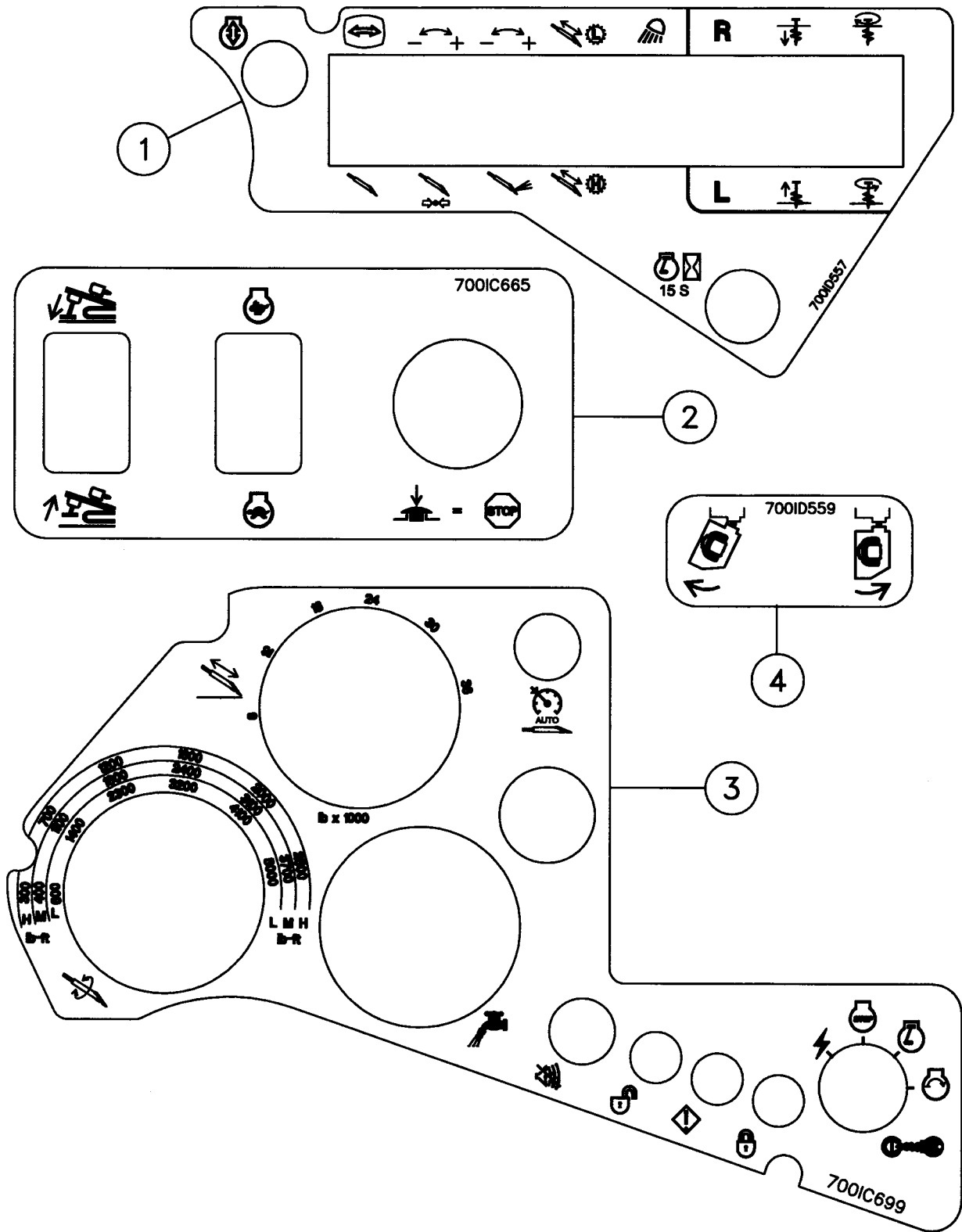





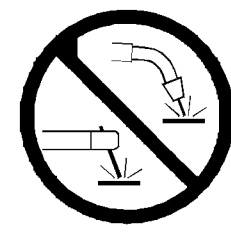
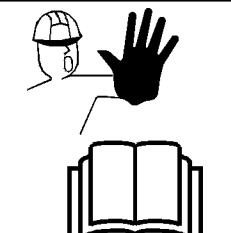
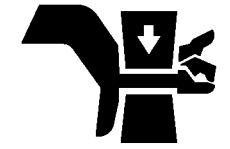
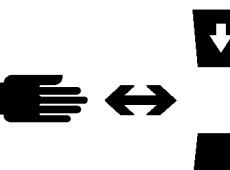

Control Fig 2-3

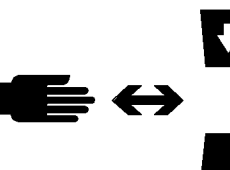

## Control Fig 2-3

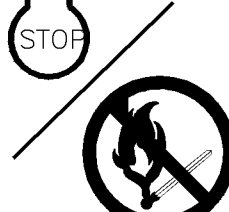
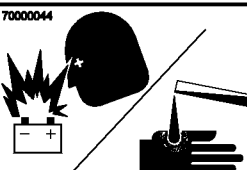
REF. NO.	*	PART NO.	DESCRIPTION	QTY.	REMARKS
1		700ID557	DECAL - CONTROL, RIGHT HAND LOWER	1	
2		700IC665	DECAL - CONTROL REAR TRANSPORT	1	
3		700IC699	DECAL - CONTROL RH UPPER D36X50II	1	
4		700ID559	DECAL - CAB SWING	1	

Safety Fig 2-4

<p><b>ATTENTION</b></p> <p>Welding Alert</p>  <p>Electronic components will be damaged if not unplugged before welding.</p> <p>Read manual for location of components and instructions to unplug before welding.</p> <p>7000C448</p>	  <p>700IC44</p>	<p><b>WARNING</b></p> <p>7000A864</p>  <p>Pinch points crush.</p>  <p>Keep hands away.</p>	<p>700IA864</p>  		
1	5	2	3	6	4
<p><b>WARNING</b></p> <p>2326324</p>  <p>Fuel and fumes can explode and burn.</p>	<p>STOP</p>  <p>No smoking. No Flame Stop engine.</p>	<p>23261324</p> 	<p>STOP</p> 		
7			8		
<p><b>WARNING</b></p> <p>70000044</p>  <p>Battery explosion can blind. Acid can blind and burn.</p>  <p>Read manual before service.</p>	<p>70001044</p>  				

## Safety Fig 2-4

REF. NO.	*	PART NO.	DESCRIPTION	QTY.	REMARKS
1		7000C446	DECAL - NO WELD	4	Domestic
2		700IC446	DECAL - NO WELD	4	International
3		7000A864	DECAL-WARNING DOMESTIC	2	Domestic
4		700IA864	DECAL-WARNING INTERNATIONAL	2	International
5		2326324	DECAL-WARNING/REFUEL	1	Domestic
6		2326I324	DECAL - WARNING EXPLOSION	1	International
7		70000044	DECAL-WARNING(AT/UND)	1	Domestic
8		7000I044	DECAL-WARNING	1	International

Safety Fig 2-5

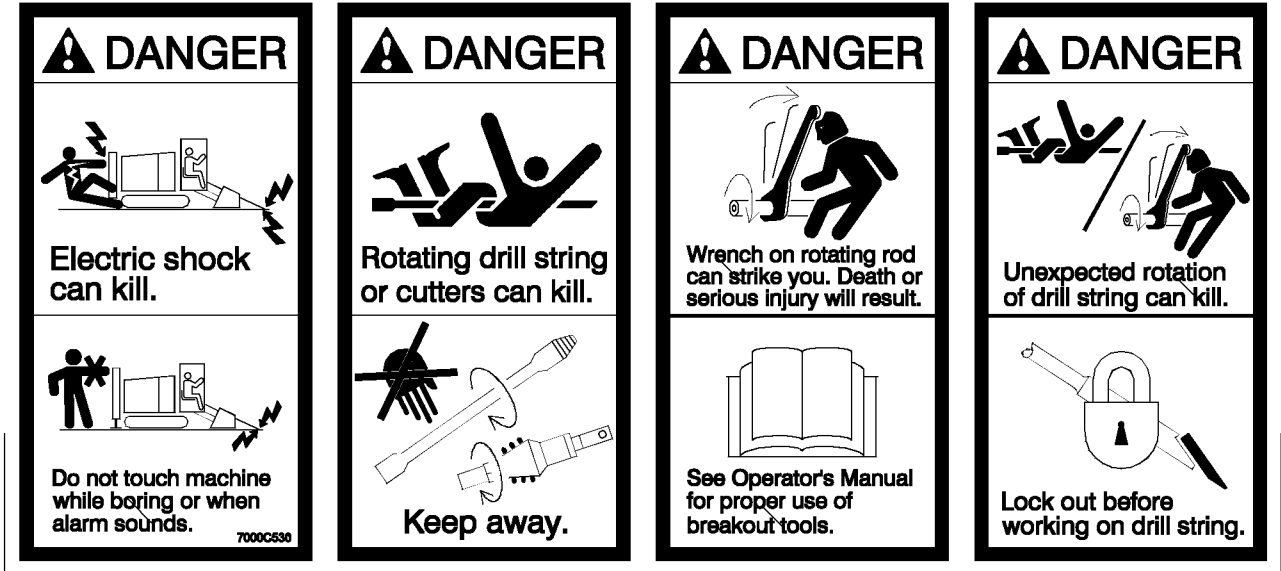

1

2

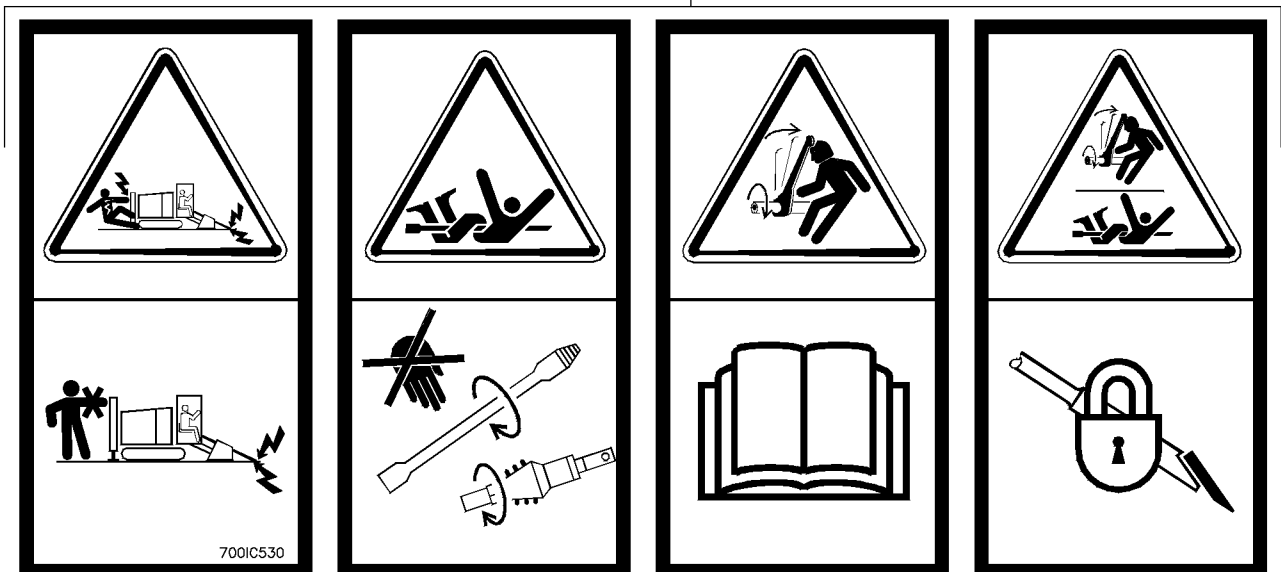



## Safety Fig 2-5

REF. NO.	*	PART NO.	DESCRIPTION	QTY.	REMARKS
1		7000C530	DECAL - DANGER 4 PANEL	1	Domestic
2		700IC530	DECAL - DANGER INTERNATIONAL 4 PANEL	1	International

Safety Fig 2-6

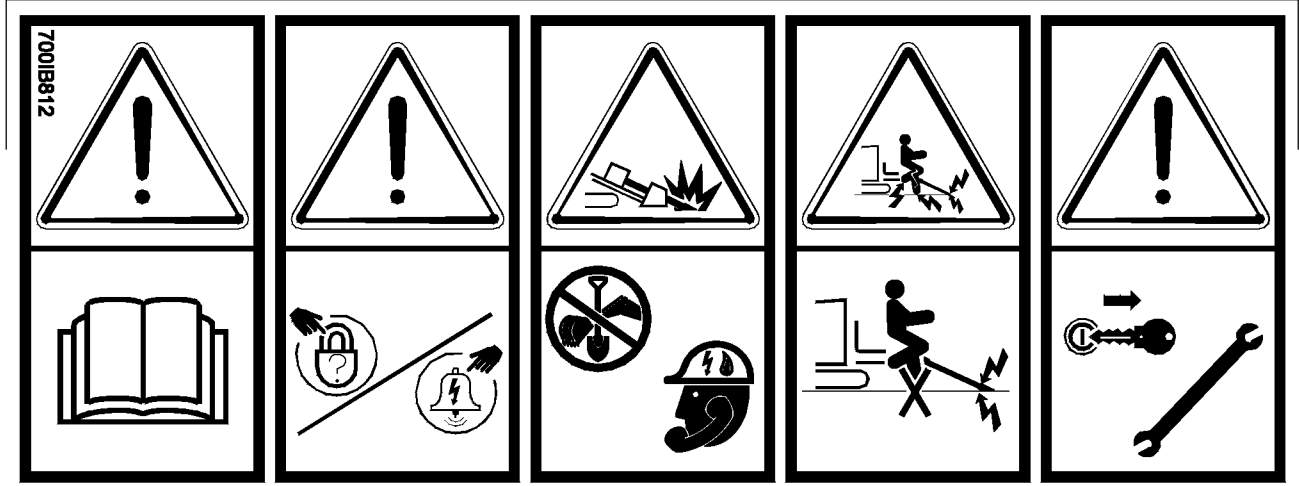
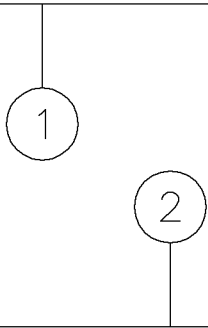
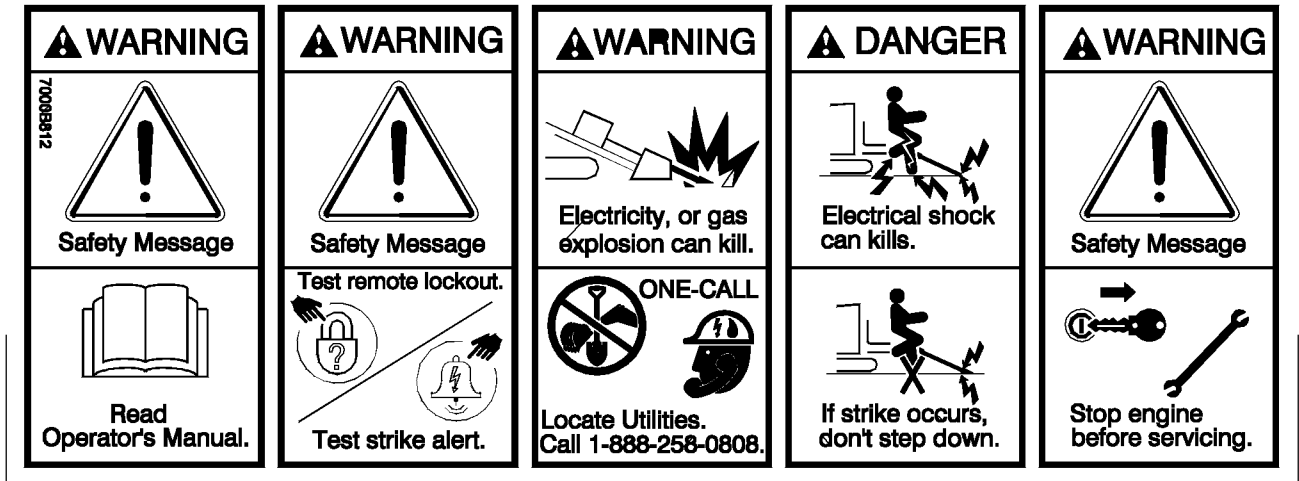

## Safety Fig 2-6

REF. NO.	*	PART NO.	DESCRIPTION	QTY.	REMARKS
1		7000B812	DECAL - WARNING	1	Domestic
2		700IB812	DECAL - WARNING	1	International

Safety Fig 2-7

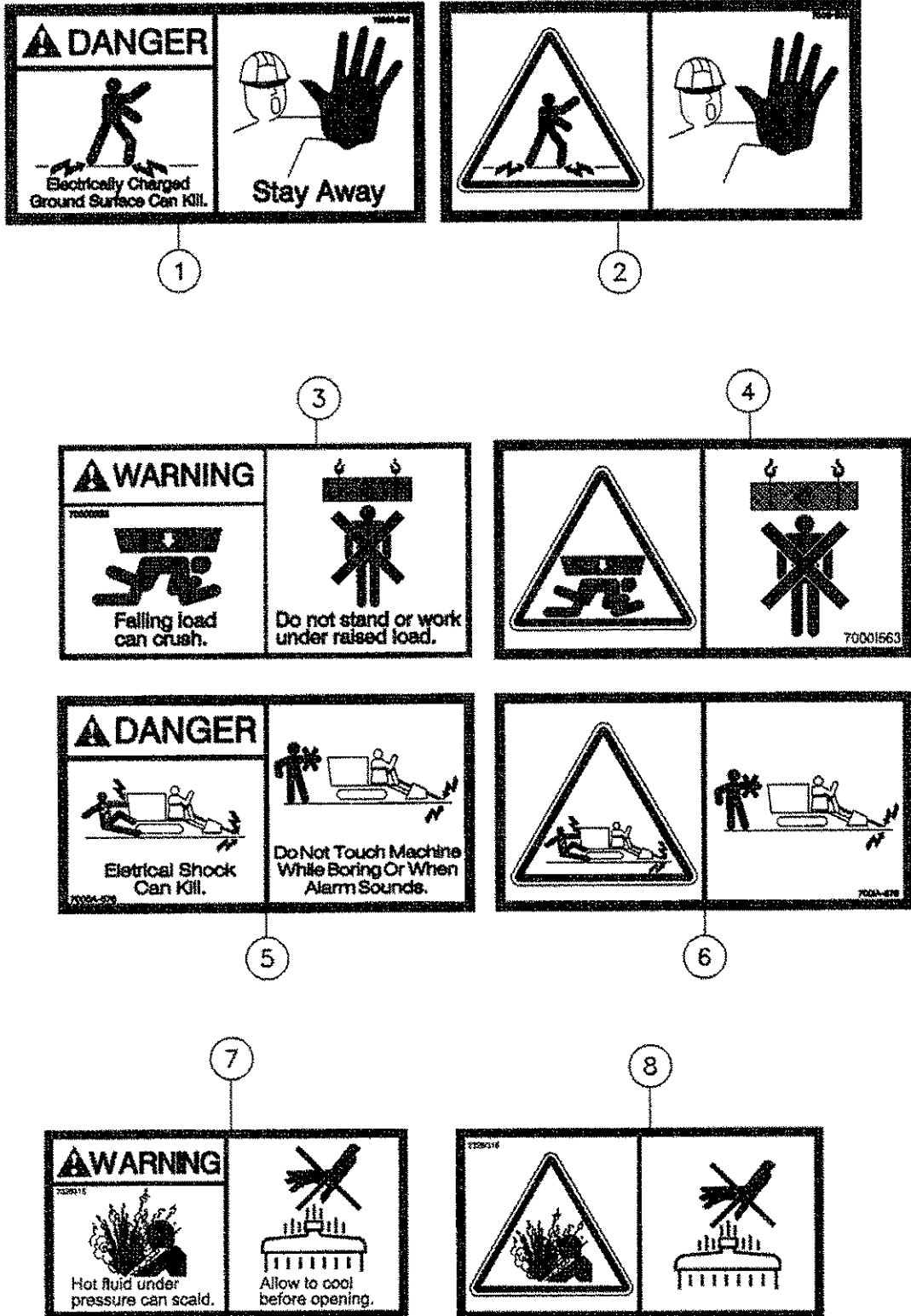

## Safety Fig 2-7

REF. NO.	*	PART NO.	DESCRIPTION	QTY.	REMARKS
1		70000530	DECAL-DANGER	4	Domestic
2		7000I530	DECAL- DANGER	4	International
3		70000563	DECAL-WARNING (UND)	4	Domestic
4		7000I563	DECAL-WARNING (UND)	4	International
5		7000A576	DECAL-DANGER	1	Domestic
6		700IA576	DECAL-DANGER	1	International
7		2326315	DECAL-WARNING	1	Domestic
8		2326I315	DECAL-WARNING	1	International

Miscellaneous Fig 2-8

Notice • Avis • Hinweis • Avviso • Aviso • 告示

If you purchased this product as used equipment, you can receive a FREE Operator's Manual by contacting:  
 Si vous avez acheté cet équipement d'occasion, vous pouvez recevoir un manuel de l'opérateur GRATUIT en composant le :

Wenn Sie diese Maschine gebraucht erworben haben, können Sie eine KOSTENLOSE Betriebsanleitung wie folgt anfordern:

Se si è comprata la presente macchina usata, si può ricevere una copia del manuale dell'operatore IN OMAGGIO, contattando:

Si este producto que ha comprado es un equipo usado, puede recibir un manual del operador GRATUITO llamando al:

如果您所购买的是旧设备，可以通过下列地址获得一本免费的操作员手册：

○ ○ ○ ○ ○ ○ ○ ○  
 Vermeer Manufacturing Company  
 ATTN: Customer Data Department  
 1210 Vermeer Road East, PO BOX 200  
 Pella, Iowa 50219 USA  
 800-828-0051 or 641-828-3141  
 Telephone: English speaking only  
 Téléphone : en anglais uniquement  
 Telefon: Nur in Englischer Sprache  
 Telefono: tutte le comunicazioni saranno in inglese  
 Teléfono: en Inglés solamente  
 电话：只能用英语交流

○ ○ ○ ○ ○ ○ ○ ○

OR by completing and mailing the Used Equipment Registration Form enclosed in the Operator's Manual.

OU en remplissant et en envoyant le formulaire d'enregistrement de l'équipement d'occasion inclus dans le manuel de l'opérateur.

ODER das in der Betriebsanleitung enthaltene Formular zur Registrierung gebrauchter Ausrüstung ausfüllen und einsenden.

OPPURE compilando e spedendo il modulo di registrazione per macchinari usati, accluso al manuale dell'operatore.

O rellenando y enviando por correo el impreso de registro de equipos usados incluido en el manual del operador.

或者通过填写并邮寄操作员手册中所附的旧设备登记表获得。

2326940

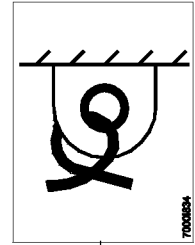

2

1

3

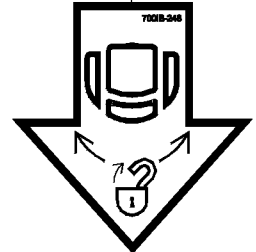

ROTATION  
PUMP CHARGE  
350 PSI

THRUST/PULLBAC  
PUMP CHARGE  
350 PSI

PFC PUMP  
250 PSI STANDBY  
3000 PSI MAX

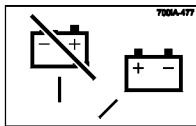

4

6

USE GRADE 2  
DIESEL FUEL  
OR BETTER

8



9

10

HYDRAULIC  
OIL

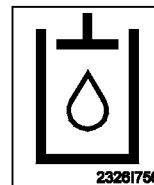

7

5

BLACK

WHITE

BLACK

WHITE

7001A-997

## Miscellaneous Fig 2-8

REF. NO.	*	PART NO.	DESCRIPTION	QTY.	REMARKS
1		2326940	DECAL-NOTICE TO OWNERS	1	
2		7000I834	DECAL - TIE DOWN POINT	7	
3		700IB248	DECAL - PUSH	2	
4		7000B300	DECAL - TEST POINT	1	
5		700IA477	DECAL_BATTERY SWITCH (UG)	1	
6		2326756	DECAL-HYDRAULIC OIL	1	Domestic
7		2326I756	DECAL-HYDRAULIC FLUID	1	International
8		70000098	DECAL-DIESEL (AT/UND)	1	Domestic
9		7000I098	DECAL-DIESEL FUEL	1	International

Miscellaneous Fig 2-9

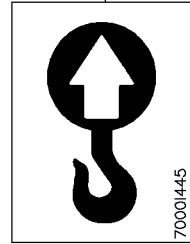
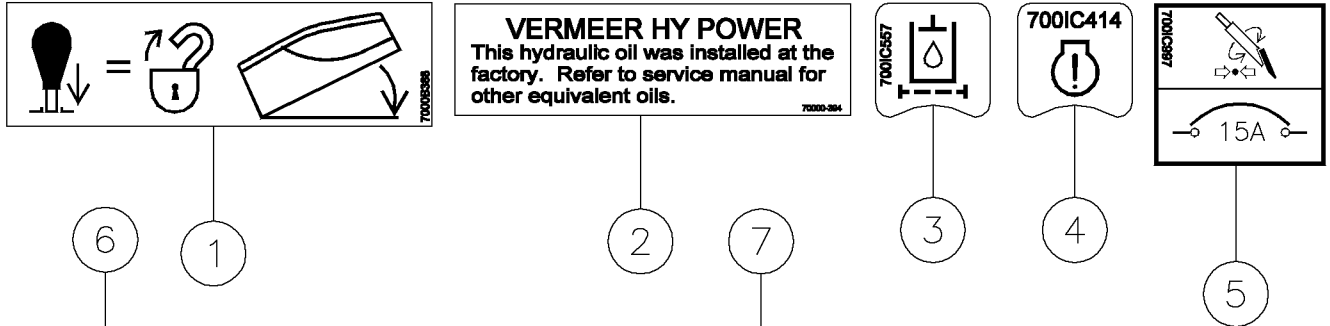

Freeze-protects entire Navigator water system

**5 U.S. GAL**

# Vermeer®

## NAVIGATOR FREEZE GUARD

### ANTI-FREEZE AND LUBRICANT

**Health Hazard Data:**

**Eyes:** May cause minor eye irritation. Flush with fresh water for approximately 20 minutes. If irritation persists, call a physician.

**Skin Contact:** Not expected to present a significant skin hazard under anticipated conditions of normal use.

**Ingestion:** Not expected to present significant ingestion hazard under anticipated conditions of normal use.

Vermeer Manufacturing Company Pella IA 50219  
70000676

- R1 - HYDRAULIC ENABLE LATCH
- R2 - SEAT SWITCH
- R3 - REMOTE LOCKOUT
- R4 - LOAD SENSE
- R6 - ROCKFIRE BALL VAVLE ON/OFF



- F1 (15A) - LEFT JOYSTICK, GREASE
  - F2 (15A) - RIGHT JOYSTICK
  - F3 (15A) - THRUST SLOWDN/STOP/ANTICRASH GEARBOX FLUSH, PSI TRANSDUCER
  - F4 (15A) - LIGHTS
  - F5 (15A) - 3 SPEED GEARBOX, H<sub>2</sub>O MODULE OUTRIGGER, ROCKFIRE
  - F6 (15A) - SEAT SWITCH, HYDRAULIC ENABLE EDC CONTROLLER
  - F7 (15A) - STAKEDOWN, REMOTE LOCKOUT-RELAY, FLEET MANAGER
  - F8 (15A) - 12 VCD OUTLET
  - F9 (15A) - HYD. ENABLE POWER TEMP/TACH GA. FLEET MANAGER
  - F10 (15A) - ENGINE START
- 70000687

This product may be covered by one or more of the following patents:

AU 756 939	US 5,553,407	US 6,332,502	US 6,533,052	US 6,880,430
CA D 79 593	US 5,556,253	US 6,357,537	US 6,554,082	US 6,886,644
CC 961801735	US 5,574,642	US 6,380,830	US 6,557,651	US 6,910,541
CC ZL00818814.9	US 5,590,041	US 6,367,584	US 6,577,954	US 6,929,075
CC ZL01801755.X	US 5,607,280	US 6,374,928	US 6,585,062	US 6,948,265
CC ZL01809457.0	US 5,611,486	US 6,382,330	US 6,588,516	US 6,975,942
DE 696 11 846.7	US 5,659,985	US 6,389,380	US 6,651,755	US 7,036,809
DE 202 14 959.5	US 5,687,807	US 6,380,207	US 6,659,202	US 7,044,684
DE Des. 98 008 85.4	US 5,704,142	US 6,408,992	US 6,668,946	US 7,055,270
DE 600068479	US 5,720,354	US 6,408,954	US 6,684,538	US RE39,259
EP 772 543	US 5,746,278	US 6,435,286	US 6,701,647	US 7,121,363
EP 830 522	US 5,768,811	US 6,439,319	US 6,719,069	US 7,143,844
EP 885 343	US 5,778,991	US 6,446,365	US 6,725,579	US 7,152,348
EP 1 153 194	US 5,819,859	US 6,454,025	US 6,729,050	US 7,172,035
EP 1 242 710	US 5,904,210	US 6,470,976	US 6,749,029	US 7,182,151
GB 2 053 636	US 5,944,121	US 6,474,931	US 6,751,553	WO N1468466
HK 1015858	US 6,109,367	US 6,474,932	US 6,751,893	
NL 1153194	US 6,119,376	US 6,477,795	US 6,752,043	
RU 2 158 952	US 6,154,987	US 6,484,818	US 6,755,263	
SW 524 375	US 6,161,830	US 6,491,115	US 6,766,889	
US Des. 396,837	US 6,195,922	US 6,497,296	US 6,804,903	
US 5,237,888	US 6,247,544	US 6,511,260	US 6,814,164	
US 5,291,964	US 6,289,997	US 6,516,899	US 6,833,795	
US 5,509,220	US 6,308,787	US 6,517,733	US 6,839,991	
US 5,544,055	US 6,315,062	US 6,533,046	US 6,845,825	

This product may be covered by one or of the following licensed patents:

US 4,694,913	US 4,867,255	US 5,148,880	US 5,867,117
US 4,858,704	US 4,953,638	US 5,799,740	US 6,050,350

(OTHER U.S. AND FOREIGN PATENTS PENDING)

7000B119 rev J



## Miscellaneous Fig 2-9

REF. NO.	*	PART NO.	DESCRIPTION	QTY.	REMARKS
1		7000B388	DECAL - HOOD LATCH	1	
2		70000394	DECAL-VERMEER HY POWER	1	
3		700IC557	DECAL - HYD. FILTER WARNING LIGHT	1	
4		700IC414	DECAL- ENGINE WARNING	1	
5		700IC997	DECAL - BRAKER RESET ROTATION LIMITER	1	
6		7000I445	DECAL-LIFT POINT	4	
7		70000675	DECAL-NAVIGATOR FREEZE GUARD	1	
8		7000C687	DECAL-BREAKER BOX D36X50	1	
9		700IB799	DECAL- SOUND POWER LEVEL (113)	1	
10		7000C686	DECAL-RELAY BOX D36X50	1	
11		7000B119	*DECAL - PATENT INDUSTRIAL	1	

Miscellaneous Fig 2-10

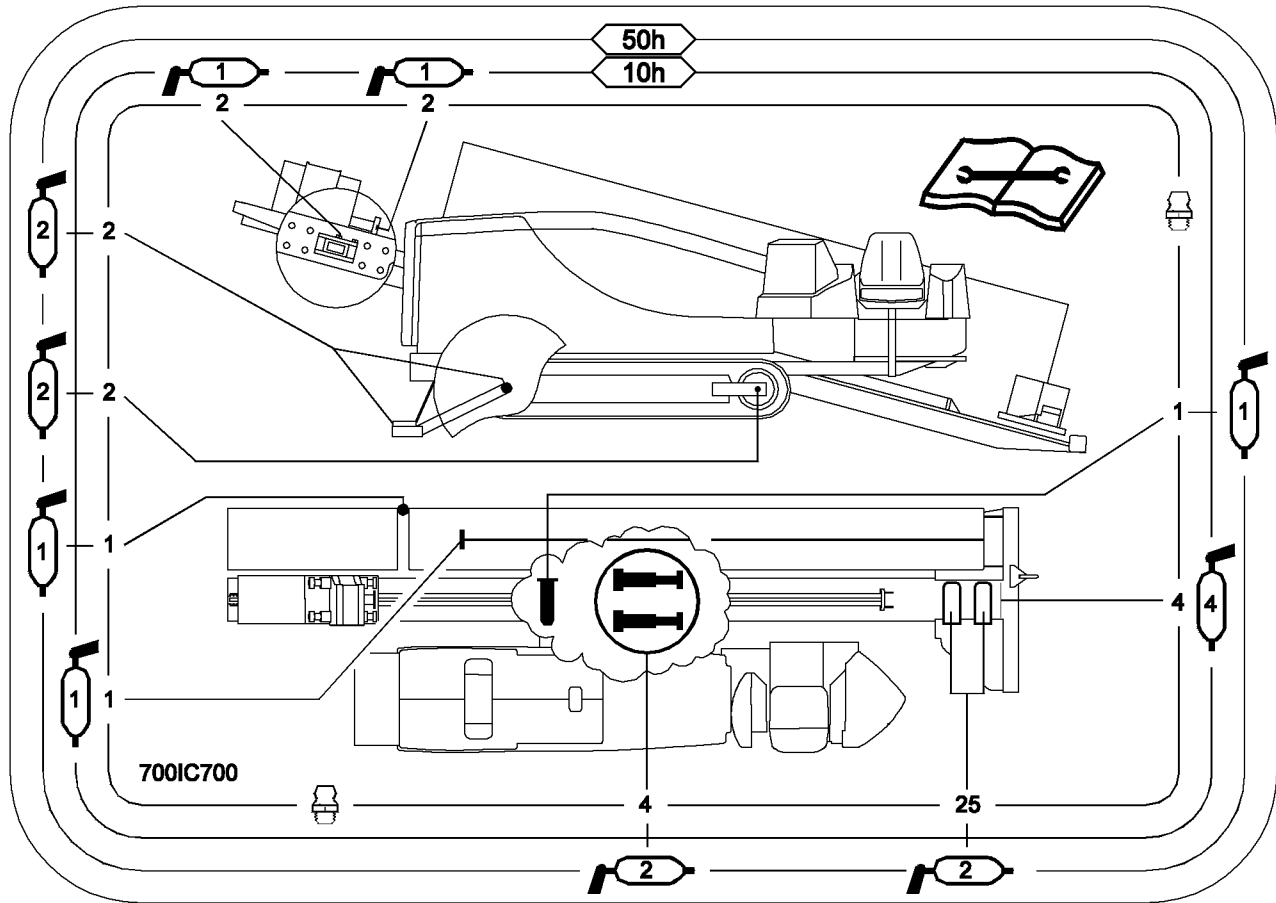

## LUBRICANT CHART

LOCATION	CAPACITY	TYPE
ENGINE OIL	WITH FILTER 15.5 QT (14.7L) W/O FILTER 14.0 QT (13.3L)	15W-40 HD -ROTELLA T MULTIGRADE -JOHN DEERE PLUS 50
HYDRAULIC OIL TANK	55 GAL (208L)	-VERMEER HYPOWER 46 -VERMEER HYPOWER 68 -VERMEER HYPOWER 100
DRILL FLUID PUMP CRANK CASE	4.5 QT (4.3L)	SAE-40 -VERMEER XTRAGOLD 40
ENGINE RADIATOR	8.0 GAL (30.3L)	MIX 50% WATER AND 50% ETHYLENE GLYCOL BASE ANTIFREEZE TO -34° F (-37° C) PROTECTION
SYSTEM ANTIFREEZE TANK	5 GAL (18.9L)	RV ANTIFREEZE
TRACK PLANETARIES	HALF FULL	ALL PURPOSE GEAR LUBE 80W-90

See Operator's Manual for detailed instructions.

7000C451

Miscellaneous Fig 2-10

REF. NO.	*	PART NO.	DESCRIPTION	QTY.	REMARKS
1		700IC700	DECAL-D36X50II GREASE CHART	1	
2		7000C451	DECAL - FLUID CAPACITIES	1	

Resource Library Fig 2-11

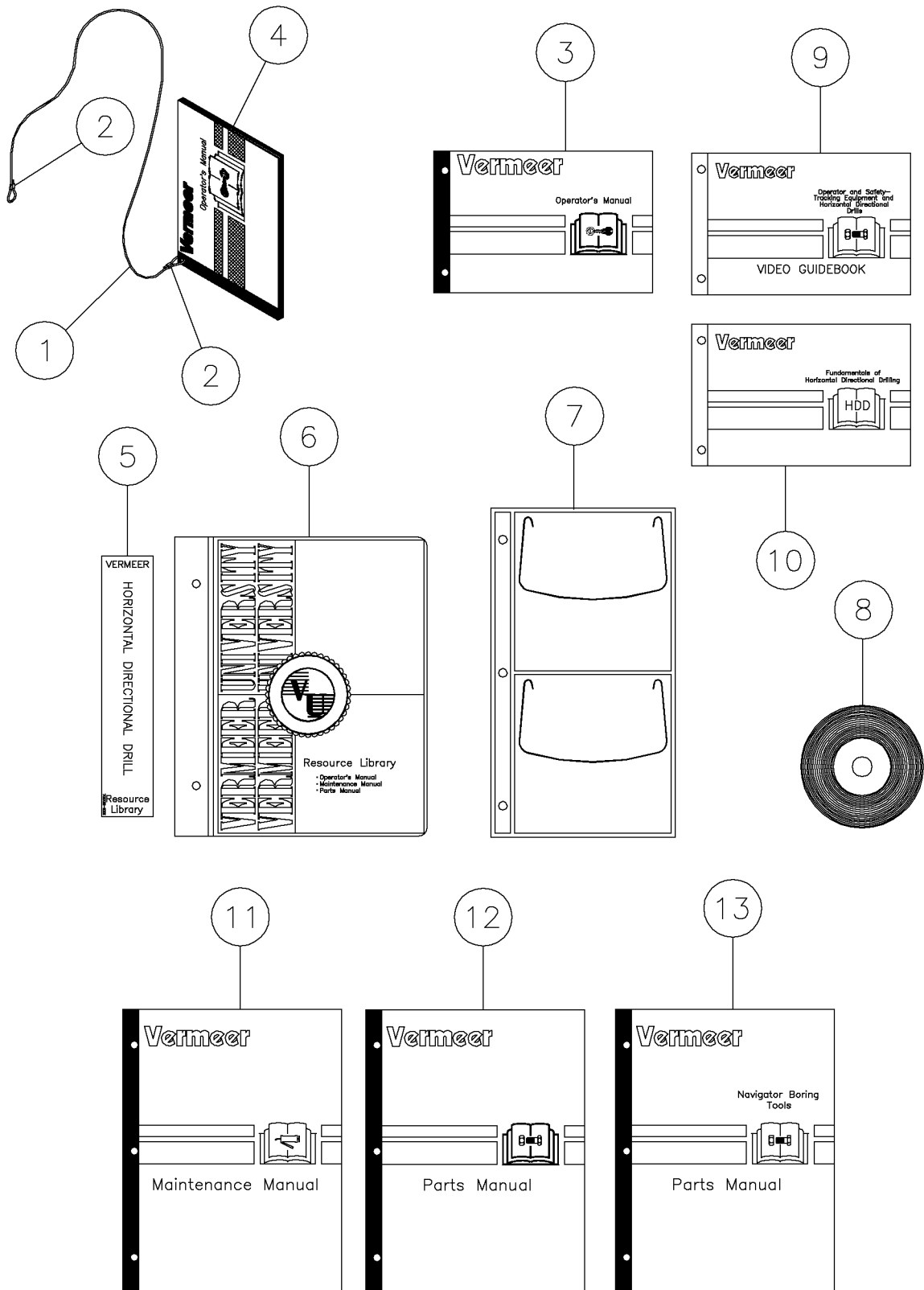

Resource Library Fig 2-11

REF. NO.	*	PART NO.	DESCRIPTION	QTY.	REMARKS
1		142954001	CABLE-.068DIA.NYLON CT.-36.00	1	
2		142423001	CRIMP-CABLE (FOR.068DIA.CABLE)	2	
3		105400Z83	OM-D36X50II HDD o2.00	1	
3		117000BA5	OM-D36X50II (SP) o2.00	1	
4		296296961	MANUAL ASSY - OM D36X50II (EN) CABLED o2.00	1	Inc. Ref. 1 & 2
4		296292941	MANUAL ASSY-D36X50II (SP) CABLED 2.00	1	Inc. Ref. 1 & 2
5		7000B222	DECAL -HORIZONTAL DRILL - RESOURCE LIB.	1	
6		144144001	NOTEBOOK BINDER - 2"-3 XCX	1	
7		180010788	DVD-HOLDER	1	
8		296296910	DVD-NTSC VIDEO HDD OPERATIONS&FIRESTICK(INCL SPAN)	1	
9		105400T90	HDD OPERATIONS & SAFETY VIDEO GUIDEBOOK	1	
10		105400W26	FUNDAMENTALS OF HDD UP o1.00	1	
11		105400Z85	MANUAL-D36X50II (MM) o2.00	1	
11		117000BA7	MM-D36X50II (SP) m2.00	1	
12		105400ZQT	PM-D36X50 II (EN) p4.00	1	
13		105400T09	PM - NAVIGATOR BORING TOOLS p4.00	1	
		296331579	D36X50II RESOURCE LIBRARY		Inc. All Items Figure.

Main Frame/Track Fig 3-1

Illustration No. 296279859

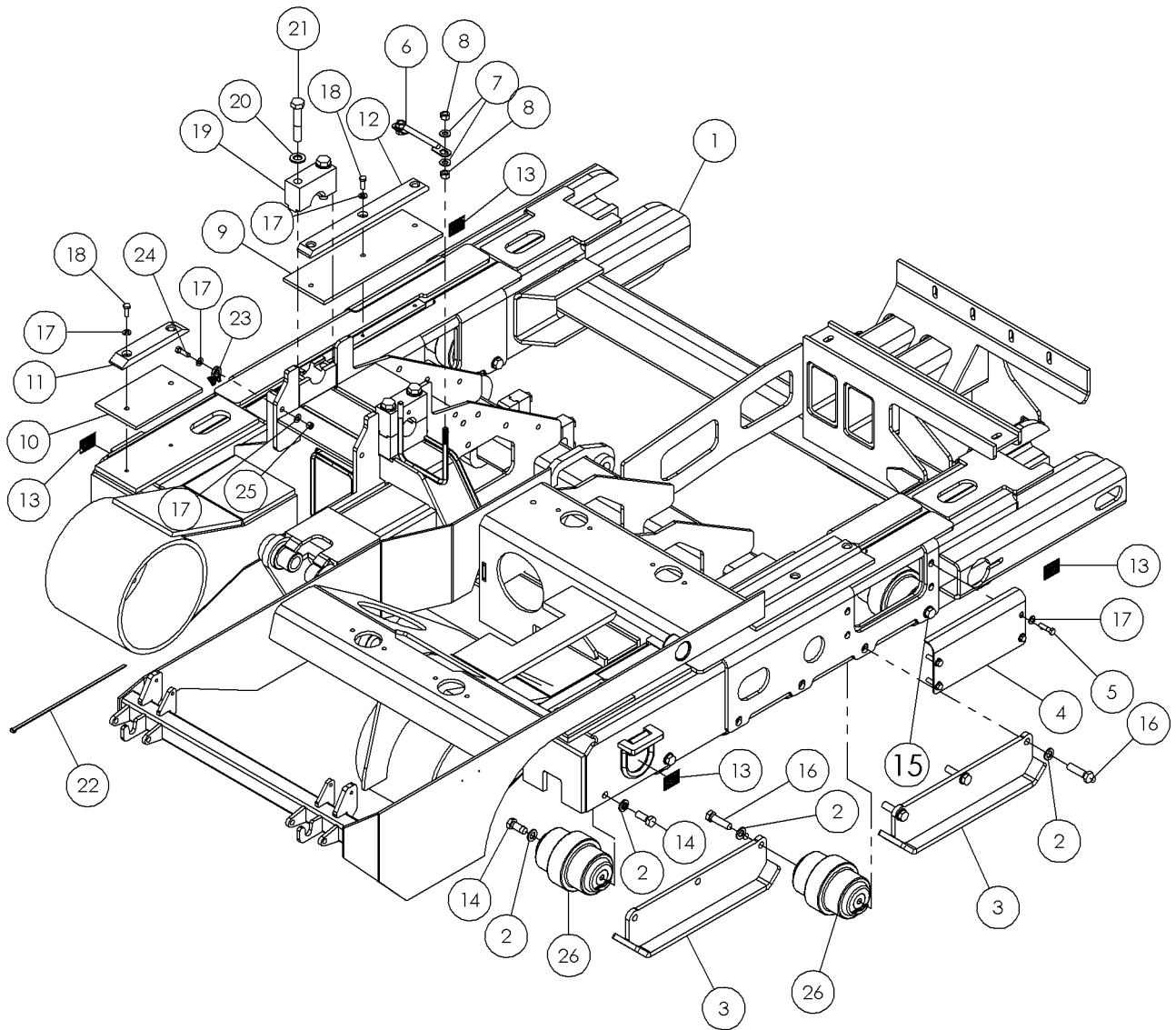

## Main Frame/Track Fig 3-1

REF. NO.	*	PART NO.	DESCRIPTION	QTY.	REMARKS
1		296287806	MAINFRAME - MEDIUM	1	
2		603946001	WASHER M16	28	
3		296275353	ROCK GUARD	4	
4		296279758	COVER - REINFORCED TRACK RAIL	2	
5		235723001	SCREW - HCS -.38 - 16 X 1.50 - GR8 - YZ	8	
6		285532001	ROD - HOSE LOOP COVER	1	
7		485025	WASHER-1/2 FLAT-HARDENED-YZ	4	
8		250512001	NUT- 1/2 NC Gr8 TOP LOCK Y/ ZINC	4	
9		244456001	BAR - LOWER TRACK WEAR	2	
10		296280079	BAR - LOWER TRACK WEAR	2	
11		285777001	BAR - UPPER TRACK WEAR	2	
12		244455001	BAR -UPPER TRACK WEAR	2	
13		7000i834	DECAL - TIE DOWN POINT	4	Domestic/International
14		249884001	BOLT-M16X40 HHCS 10.9DIN933 ZN	12	
15		508478050	SCREW-HCS,M16- 2.00X50,10.9,YZ,ISO4017,FT	4	
16		508478060	SCREW-HCS,M16- 2.00X60,10.9,YZ,ISO4014,PT	12	
17		235713001	WASHER - FLATSTRL - .38 - .41 X .81 - .06-YA-A325	20	
18		235727001	SCREW-HCS-.38-16X1.00-GR8-YZ	10	
19		296277259	BLOCK PIVOT MOUNT TOP	2	
20		235717001	WASHER - 3/4" HARDENED FLAT YZ	4	
21		238881001	BOLT-3/4-10 X 4 HHCS GR8 ZY	4	
22		58151001	STRAP-CABLE TIE-T120R-0 15"	1	
23		296276018	MOUNT HELLER MANN TITON	1	
24		235736001	BOLT-3/8-16X1 1/4 ZYC	1	
25		235725001	NUT - HEX - .38 - 16 - GR8 - YZ	1	
26		296307930	ROLLER - LOWER TRACK	14	

Track Drive Motor Fig 3-2

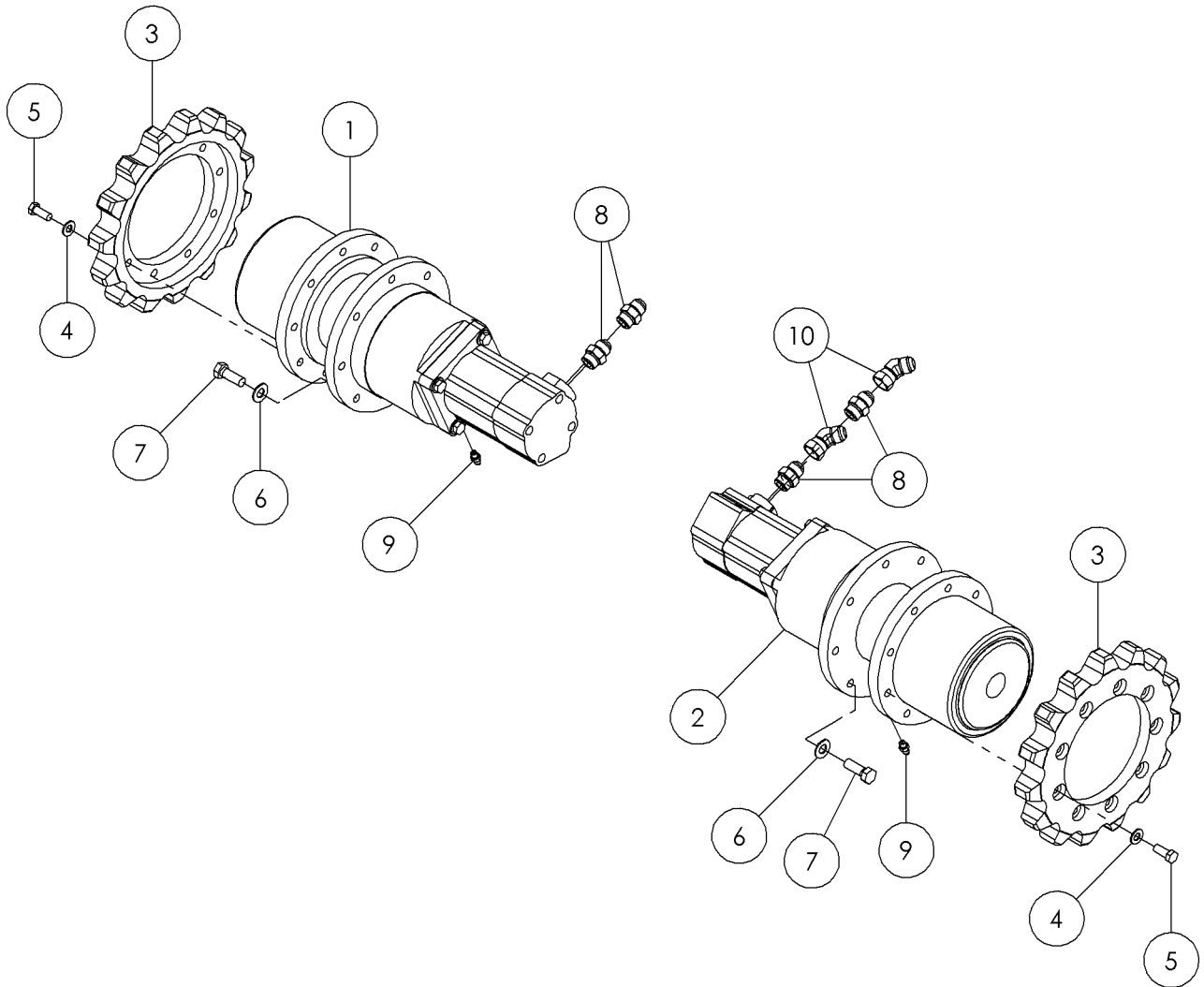

Illustration No. 296279915



## Track Drive Motor Fig 3-2

REF. NO.	*	PART NO.	DESCRIPTION	QTY.	REMARKS
1		278999001	PLANETARY ASSEMBLY - LEFT	1	Breakdown Fig. 3-2z01 Thru 3-2z03
2		291553001	PLANETARY ASSEMBLY - RIGHT	1	Breakdown Fig. 3-2z01 Thru 3-2z03
3		244467001	SPROCKET - 15T TRACK DRIVE	2	
4		485025	WASHER-1/2 FLAT-HARDENED-YZ	18	
5		508347001	BOLT-1/2 X 20-1 1/4 GR8 HE ZY	18	
6		235715001	WASHER-FLATSTRL-5/8" YZ A325	16	
7		230728001	BOLT-5/8-11X1 3/4GR 8 PLATED	16	
8		53828001	#12M O-RING-#12M JIC ST.	4	
9		60908001	FITTING-4MX4M JIC STR ADAPTER	2	
10		58017001	12FS JICX12M JIC 45 DEG	2	

Components-Planetary Fig 3-2z01

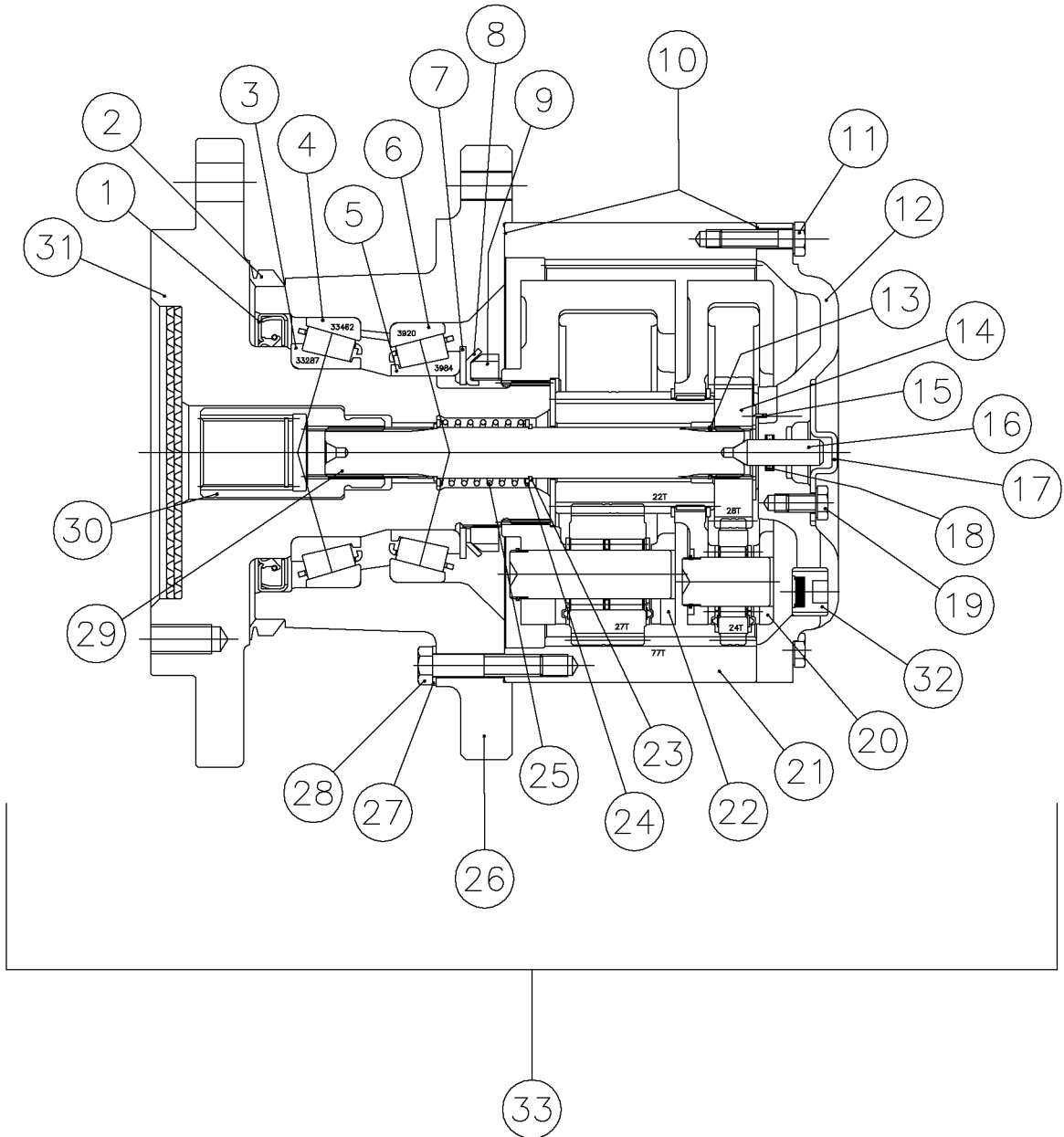

## Components-Planetary Fig 3-2z01

REF. NO.	*	PART NO.	DESCRIPTION	QTY.	REMARKS
1		244405057	SEAL - OIL	1	
2		244405055	SEAL - V RING	1	
3		244405053	BEARING - CONE	1	
4		244405051	BEARING - CUP	1	
5		244405049	BEARING - CONE	1	
6		244405047	BEARING - CUP	1	
7		244405045	WASHER - THRUST	1	
8		244405043	WASHER - LOCK	1	
9		244405041	NUT - LOCK	1	
10		244405039	COMPOUND - SEALING	2	
11		221652037	BOLT	8	
12		244405037	COVER	1	
13		244405035	RING - RETAINING	1	
14		244405033	GEAR - PRI SUN	1	
15		244405031	WASHER - THRUST	1	
16		244405029	PLUNGER	1	
17		244405027	COVER - DISENGAGE	1	
18		244405025	O-RING	1	
19		244405023	BOLT - HEX HEAD	2	
20		244405021	ASSEMBLY - PRI CARRIER	1	
21		244405019	GEAR - RING	1	
22		244405017	ASSEMBLY - SEC CARRIER	1	
23		244405015	RING - RETAINING	2	
24		244405013	WASHER - THRUST	2	
25		244405011	SPRING - DISENGAGE	1	
26		244405009	HUB	1	
27		221652013	WASHER	18	
28		221652011	BOLT	18	
29		244405007	SHAFT - IMPUT	1	
30		244405005	COUPLING	1	
31		244405003	SPINDLE	1	
32		221652035	MAGNETIC PLUG	1	
33		244405001	GEARBOX - PLANETARY 7WC14150ZX		Inc. All Items In Figure

Components-Track Drive Park Brake Fig 3-2z02

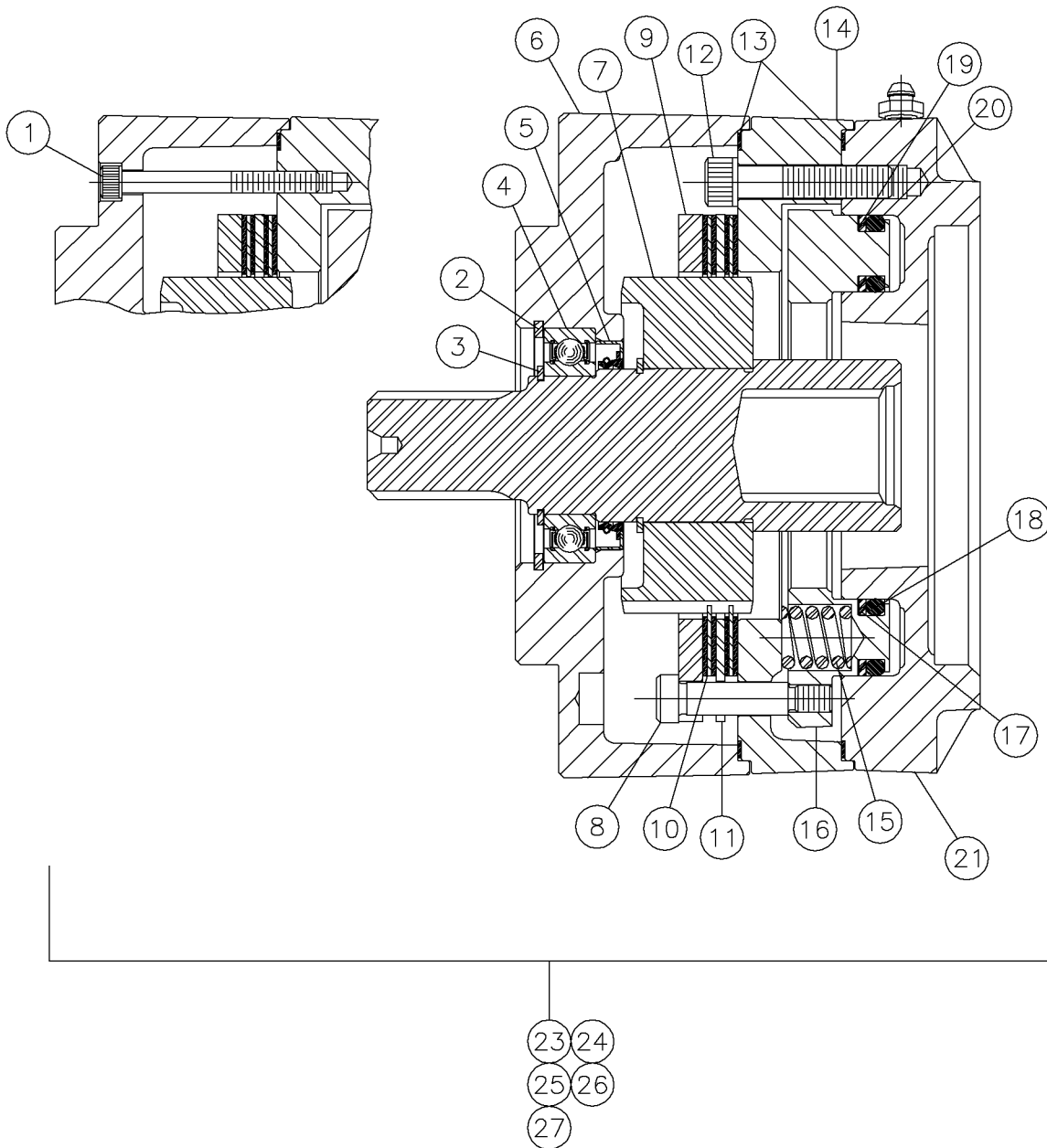

## Components-Track Drive Park Brake Fig 3-2z02

REF. NO.	*	PART NO.	DESCRIPTION	QTY.	REMARKS
1			BOLT-SOCKET HEAD	2	Not Sold Separately
2			RING-RETAINING	1	Not Sold Separately
3			RING-RETAINING	1	Not Sold Separately
4			BEARING	1	Not Sold Separately
5			SEAL-OIL	1	Not Sold Separately
6			COVER	1	Not Sold Separately
7			SPINE SHAFT ASSY	4	Not Sold Separately
8			BOLT-SOCKET HEAD SHOULDER	4	Not Sold Separately
9			DISC-PRIMARY	1	Not Sold Separately
10			DISC-ROTOR	5	Not Sold Separately
11			DISC-STATOR	4	Not Sold Separately
12			SCREW-SOCKET HEAD CAP	4	Not Sold Separately
13			GASKET	2	Not Sold Separately
14			PLATE-SPRING	1	Not Sold Separately
15			SPRING	8	Not Sold Separately
16			PISTON	1	Not Sold Separately
17			BACK-UP RING	1	Not Sold Separately
18			O-RING	1	Not Sold Separately
19			BACK-UP RING	1	Not Sold Separately
20			O-RING	1	Not Sold Separately
21			PLATE-PRESSURE	1	Not Sold Separately
22			PIN-DOWEL	2	Not Sold Separately-Not Shown
23		278785003	O-RING & BACK UP RING KIT	1	Inc. Ref. 5, 13, 17-20, And Loctite
24		278785005	STANDARD TORQUE LINING KIT	1	Inc. Ref. 4-5, 13, & Loctite
25		278785007	BEARING KIT	1	Inc. Ref. 13, 15, & Loctite
26		278785009	SPRING KIT	1	Inc. Ref. 9-11, 13 & Loctite
27		278785001	BRAKE-TRACK DRIVE PARK		Inc. All Items In Figure

Components-Track Drive Motor Fig 3-2z03

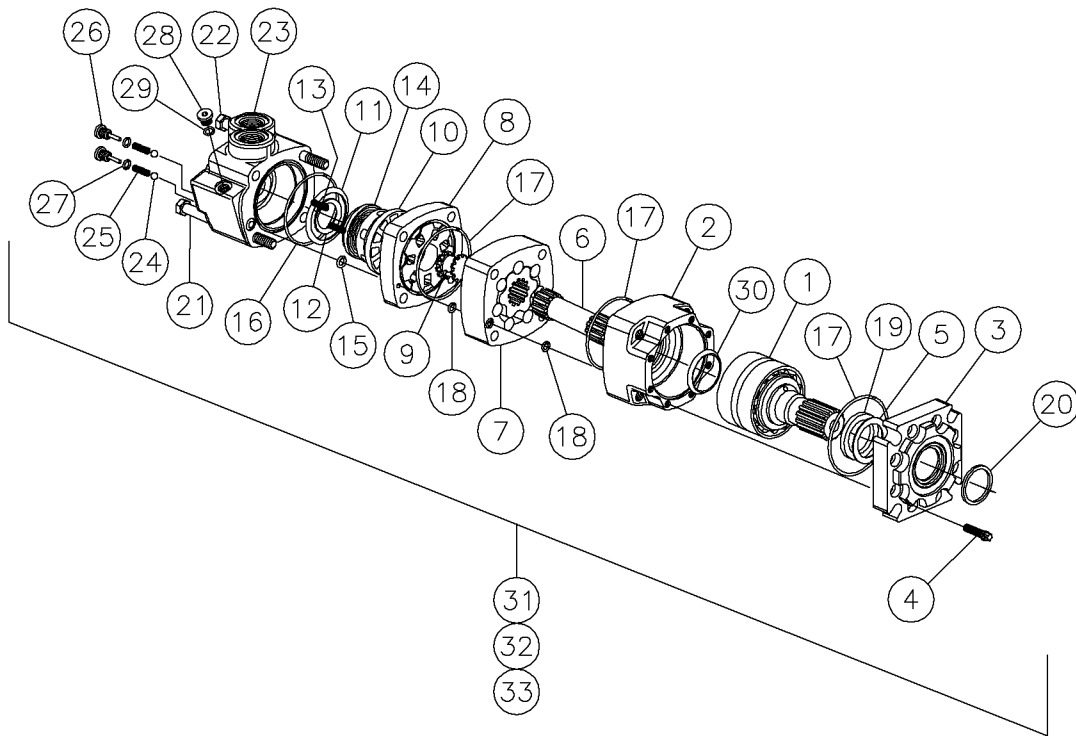

## Components-Track Drive Motor Fig 3-2z03

REF. NO.	*	PART NO.	DESCRIPTION	QTY.	REMARKS
1		251105003	SHAFT AND BEARING KIT	1	
2		13514011	HOUSING-BEARING 8487	1	
3		13514009	SHAFT & BEARING KIT 8709-1	1	
4		57982013	SCREW	8	
5		775011	WASHER-BACKUP 6943	1	
6		251105005	DRIVE-MAIN	1	
7			GEROLER	1	Not Sold Separately
8		600076017	PLATE-VALVE	1	
9		600076019	VALVE	1	
10		600076021	VALVE	1	
11		775041	SEAL-OUTER FACE 6962	1	
12		775043	SEAL-FACE INNER 6961	1	
13		224408017	SPRING	2	
14		53853017	BALANCE RING&PINS 21316CHARLYN	1	
15		4485011	O-RING-250003-903 (90D)	2	
16		775049	SEAL-9022-007	1	
17		13514033	SEAL 3 1/2" (O-RING)	3	
18		215338009	SEAL	2	
19		53853005	SEAL-SHAFT 9057-12 CHAR-LYNN	1	
20		53853003	SEAL-DUST 9031-1 CHAR-LYNN	1	
21		251105007	SCREW - CAP	3	
22		251109009	SCREW-CAP	1	
23		57982023	VALVE-HOUSING ASSY	1	
24		224408035	BALL	2	
25		224408037	SPRING	2	
26		224408039	PLUG/O-RING S/A	2	
27		4485011	O-RING-250003-903 (90D)	2	
28		120872025	HEX PLUG	1	
29		1749025	SEAL-O RING 15007 (90D)	1	
30		600076033	SEAL-SHAFT FACE	1	
31		53853027	REPAIR KIT-MOTOR 61234 CHARLYN	1	Inc. Ref. 11-12, 15-16, 18, 27, & 29
32		53853025	REPAIR KIT-SHAFT 61236 CHARLYN	1	Inc. Ref. 5, 17, 19-20, & 28
33		251105001	MOTOR-7.9 CID 4000 SERIES HYD.	1	Inc. All Items In Figure

Track Tightener Fig 3-3

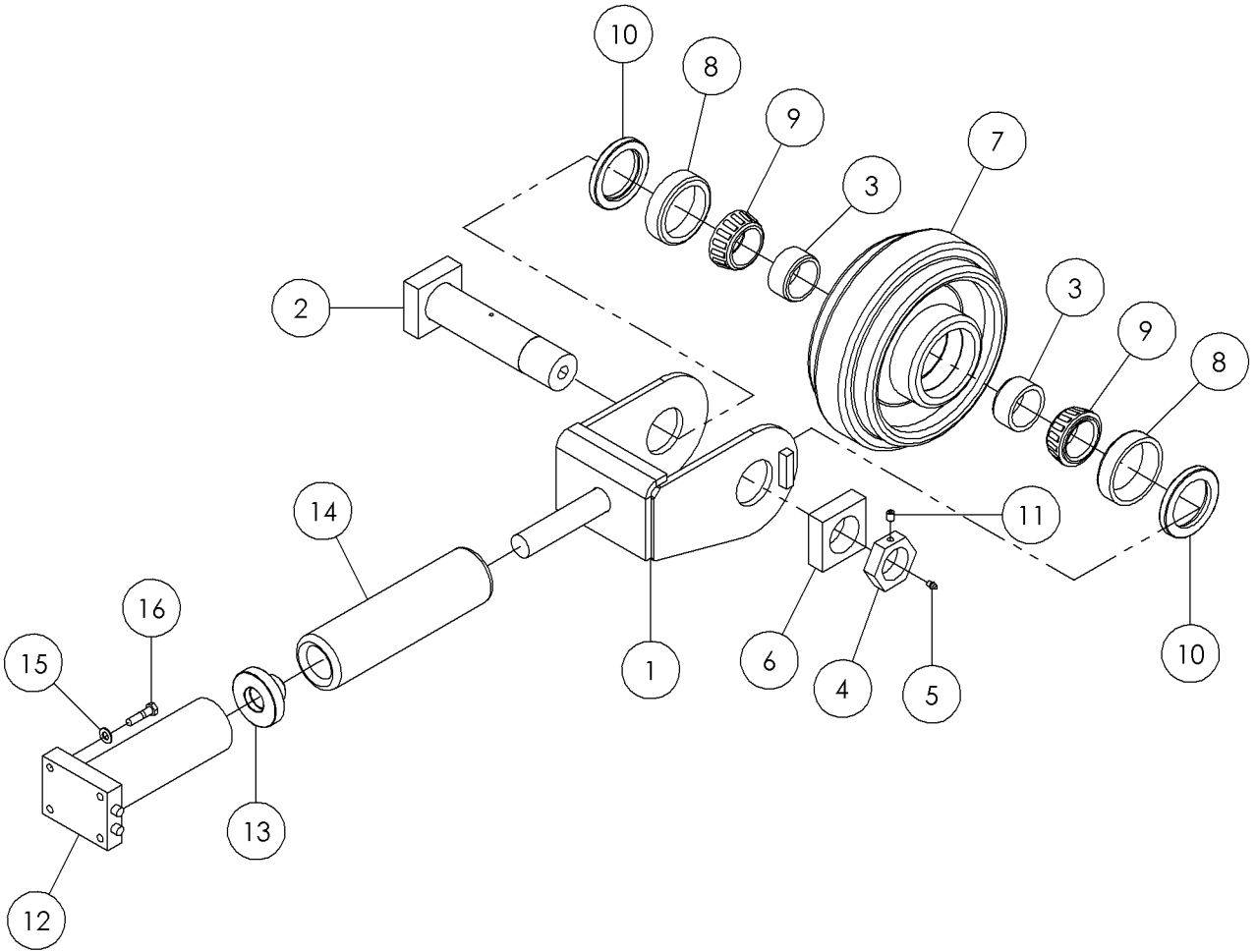



## Track Tightener Fig 3-3

REF. NO.	*	PART NO.	DESCRIPTION	QTY.	REMARKS
1		294562001	BRACKET - TRACK END ROLLER	2	
2		251129001	PIN-FRONT IDLER	2	
3		280532001	SPACER-IDLER ROLLER	4	
4		251131001	NUT-FRONT IDLER	2	
5		598001	FITTING-1/4" NF ST GREASE ZERK	2	
6		251423001	BLOCK-IDLER ROLLER BOLT	2	
7		251203001	ROLLER - FRONT TRACK	2	
8		1715011	TIMKEN CUP 2" #3730	4	
9		1716011	TIMKEN CONE 2" #3775	4	
10		3967001	SEAL -#25091 C/R	4	
11		530001	SSS-3/8-16X1/2	2	
12		296275159	CYLINDER-2.50X4.50 GREASE	2	
13		251432001	CAP-ROD	2	
14		251101001	SPRING-3.0 OD X25/32W X 13 1/2	2	
15		235713001	WASHER-FLATSTRL-.38-.41X.81-.06-YA-A325	8	
16		235723001	SCREW-HCS-.38-16X1.50-GR8 - YZ	8	

Steel/Rubber Tracks (S/N 580-) Fig 3-4r01

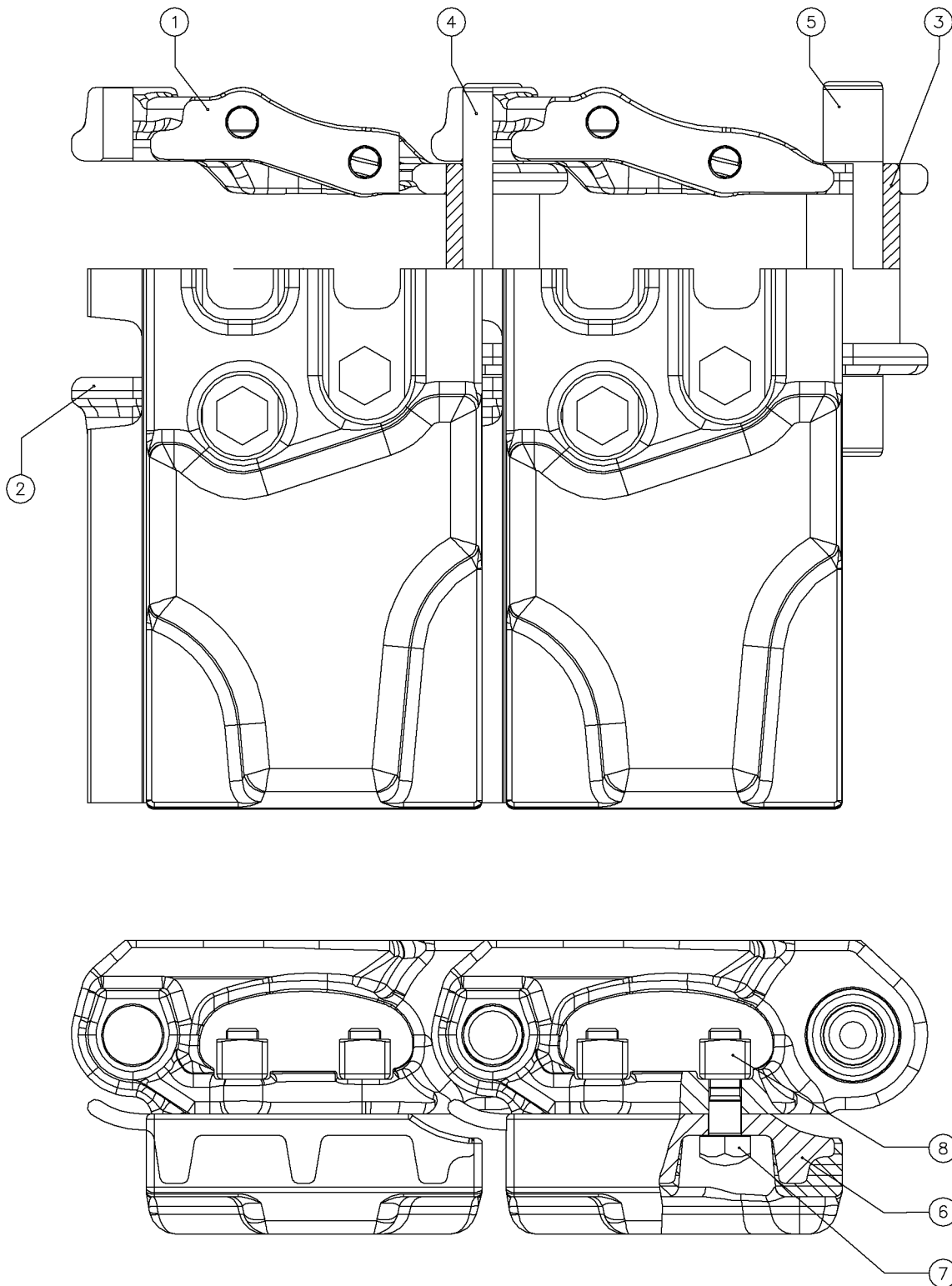

## Steel/Rubber Tracks (S/N 580-) Fig 3-4r01

REF. NO.	*	PART NO.	DESCRIPTION	QTY.	REMARKS
1		296332345	TRACK LINK, R.H. 36	36	
2		296332346	TRACK LINK, L.H. 36	36	
3		296332347	TRACK BUSHING 36	36	
4		296332348	TRACK PIN 35	35	
5		296332349	TRACK PIN, MASTER 1	1	
6		296332350	SHOE, TRIPLE GROUSER 400MM, OPEN CENTER	36	Steel
6		296332353	SHOE, RUBBER, 400MM	36	Rubber
7		296332351	TRACK SHOE BOLT, M12 X 1. L=40MM 144	144	
8		296332352	TRACK SHOE NUT, M12X 1 144	144	
		296332344	LINK ASSEMBLY, UNSEALED, 38 SECT. 1		Inc. Ref's 1 Thru 5.
		278855001	STEEL TRACK ASSY		Inc. All Items In Figure.
		278856001	RUBBER TRACK ASSY		Inc. All Items In Figure.

Steel/Rubber Tracks (S/N 552-579) Fig 3-4

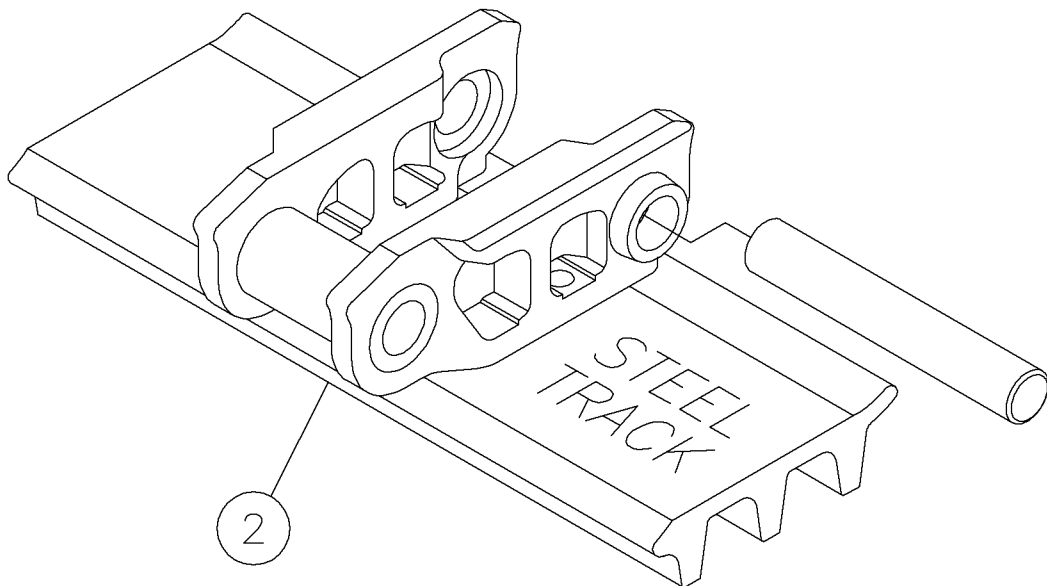
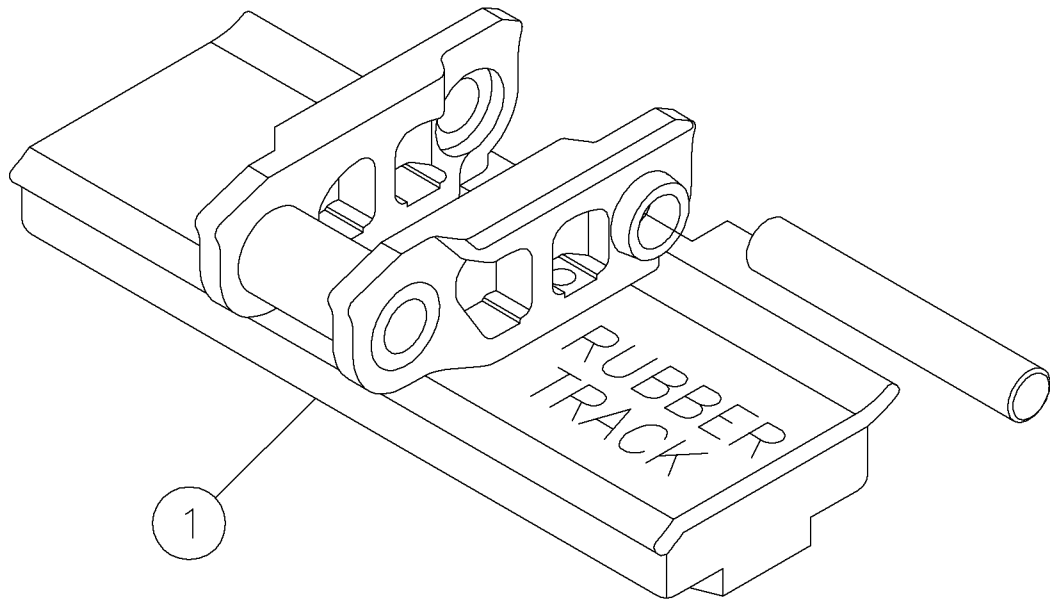

## Steel/Rubber Tracks (S/N 552-579) Fig 3-4

REF. NO.	*	PART NO.	DESCRIPTION	QTY.	REMARKS
1		251102001	TRACK - 36 SECTION RUBBER	2	
		230841003	SECTION-TRACK (RUBBER)	36	
		230840005	PIN-MASTER	1	
		230840007	PIN-TRACK	35	
2		251103001	TRACK - 36 SECTION STEEL	2	
		230840003	SECTION-TRACK (STEEL)	36	
		230840005	PIN-MASTER	1	
		230840007	PIN-TRACK	35	

Rack-15' Fig 3-5

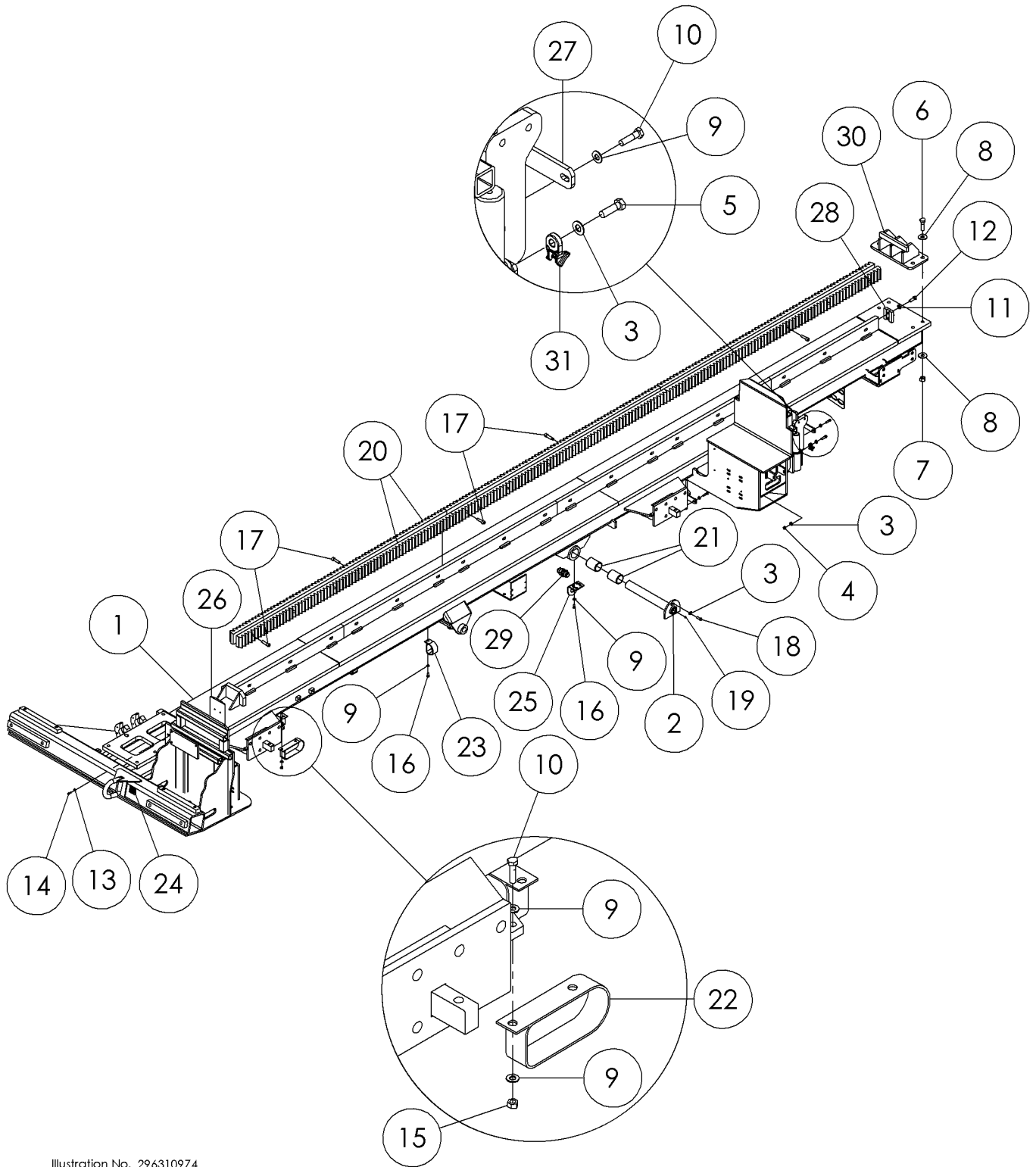

Illustration No. 296310974

## Rack-15' Fig 3-5

REF. NO.	*	PART NO.	DESCRIPTION	QTY.	REMARKS
1		296310973	WELDMENT - RACK 15 FT D36X50II	1	
2		296275355	PIN - RACK PIVOT	1	
3		235713001	WASHER-FLATSTRL-.38-.41X.81-.06-YA-A325	3	
4		235725001	NUT - HEX - .38 - 16 - GR8 - YZ	1	
5		235736001	BOLT-3/8-16X1 1/4 ZYC	1	
6		238880001	BOLT-3/4-10X2 1/2 HHCS GR8 ZY	4	
7		235739001	NUT-3/4-10 GR8 ZYC	4	
8		510337617	WASHER-FLATSTD-.75-.81X2.00-.15-YZ	8	
9		235714001	WASHER-FLATSTRL-.31-.34X.69-.06-YZ-A325	16	
10		248031001	BOLT-5/16-18X1 1/4 GR8 ZYC	7	
11		485025	WASHER-1/2 FLAT-HARDENED-YZ	2	
12		235721001	BOLT-1/2-13X1 1/2 GR8 ZINC PLT	2	
13		235716001	WASHER-FLATSTRL-.25-.28 X .63 - .06 - CZ	2	
14		235734001	BOLT-1/4-20X3/4 GR8 ZYC	2	
15		235741001	NUT - HEX - .31 - 18 - GR8 -YZ	1	
16		235742001	BOLT-5/16-18X3/4 GR8 ZYC	8	
17		229144001	CAPSCREW- 1/2-13 X 1 3/4SOC.HD	18	
18		235727001	SCREW-HCS-.38-16X1.00-GR8-YZ	1	
19		598001	FITTING-1/4" NF ST GREASE ZERK	1	
20		276318001	RACK - SIDE	6	
21		276336001	BSHNG-2 3/8ODX2.00ID-3.00 CNNX	2	
22		278902001	STRAP - DOUBLE SLEEVE HANGER	3	
23		278901001	STRAP - HOSE SLEEVE HANGER	2	
24		70001834	DECAL - TIE DOWN POINT	1	
25		296280950	TAB - BULKHEAD	1	
26		296280137	PLATE - ROD GUARD	1	
27		296284051	STRAP - HOSE SUPPORT	3	
28		277132001	CAP - RACK END	1	
29		81698001	FITTING-16MJIC BULKHEAD STR.	1	
30		296280209	WELDMENT - END STOP	1	
31		296276018	MOUNT HELLER MANN TITON	1	

Rack-10' Fig 3-6

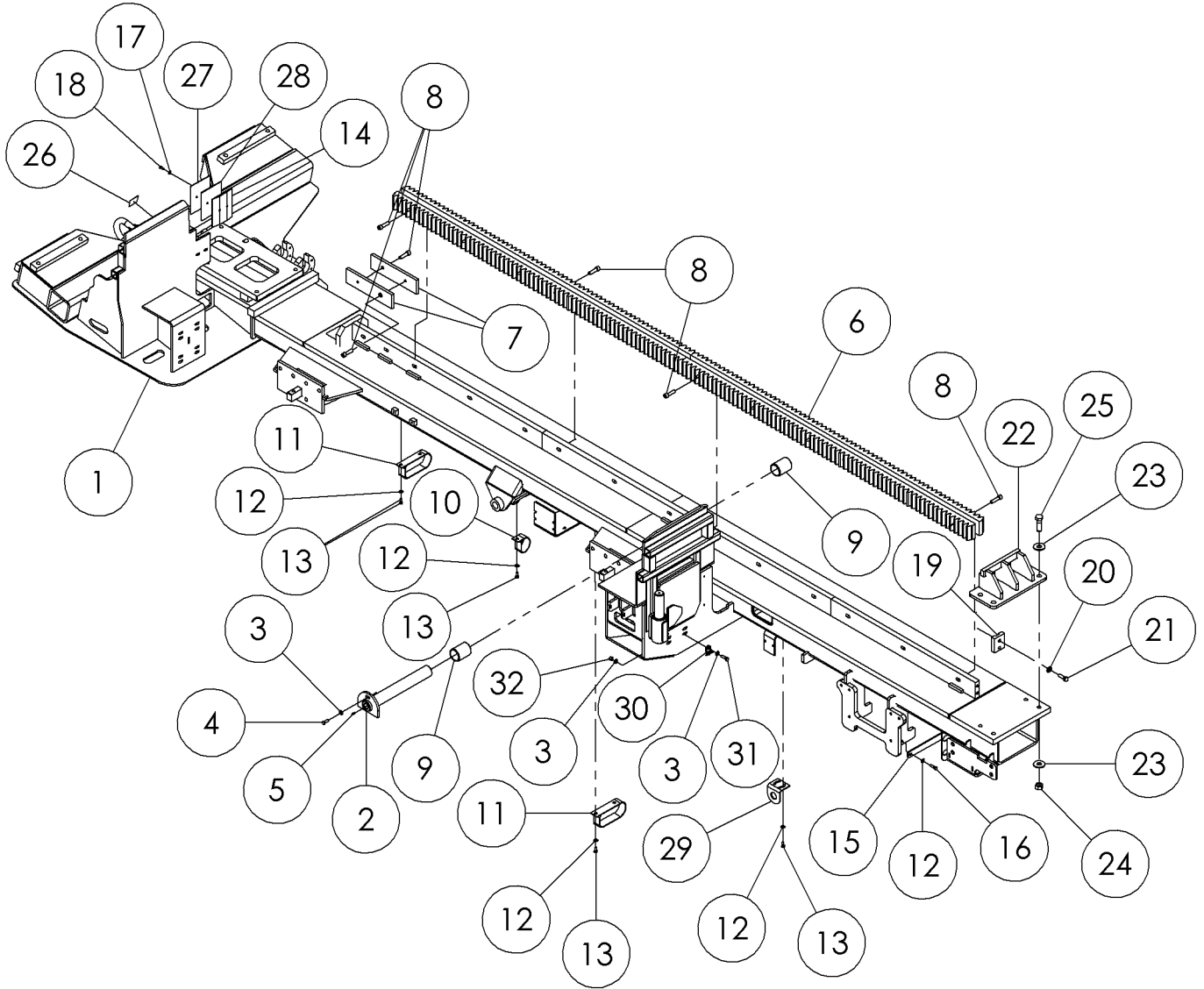

Illustration No. 296310971



## Rack-10' Fig 3-6

REF. NO.	*	PART NO.	DESCRIPTION	QTY.	REMARKS
1		296310966	WELDMENT - RACK 10' D36X50II	1	
2		296275355	PIN - RACK PIVOT	1	
3		235713001	WASHER-FLATSTRL-.38-.41X.81-.06-YA-A325	3	
4		235727001	SCREW-HCS-.38-16X1.00-GR8-YZ	1	
5		598001	FITTING-1/4" NF ST GREASE ZERK	1	
6		276318001	RACK - SIDE	4	
7		294528001	BAR - RACK SPACER	2	
8		229144001	CAPSCREW- 1/2-13 X 1 3/4SOC.HD	14	
9		276336001	BSHNG-2 3/8ODX2.00ID-3.00 CNNX	2	
10		278901001	STRAP - HOSE SLEEVE HANGER	2	
11		278902001	STRAP - DOUBLE SLEEVE HANGER	2	
12		235714001	WASHER-FLATSTRL-.31-.34X.69-.06-YZ-A325	12	
13		235742001	BOLT-5/16-18X3/4 GR8 ZYC	8	
14		296280137	PLATE - ROD GUARD	1	
15		296284051	STRAP - HOSE SUPPORT	2	
16		248031001	BOLT-5/16-18X1 1/4 GR8 ZYC	4	
17		235716001	WASHER-FLATSTRL-.25-.28 X .63 - .06 - CZ	2	
18		235734001	BOLT-1/4-20X3/4 GR8 ZYC	2	
19		277132001	CAP - RACK END	1	
20		485025	WASHER-1/2 FLAT-HARDENED-YZ	2	
21		235721001	BOLT-1/2-13X1 1/2 GR8 ZINC PLT	2	
22		296280209	WELDMENT - END STOP	1	
23		510337617	WASHER-FLATSTD-.75-.81X2.00-.15-YZ	8	
24		235739001	NUT-3/4-10 GR8 ZYC	4	
25		238880001	BOLT-3/4-10X2 1/2 HHCS GR8 ZY	4	
26		7000i834	DECAL - TIE DOWN POINT	1	
27		296280222	PLATE - SHIM ROD GUARD	1	
28		296280223	PLATE - SHIM ROD GUARD	1	
29		296280950	TAB - BULKHEAD	1	
30		296276018	MOUNT HELLER MANN TITON	1	
31		235736001	BOLT-3/8-16X1 1/4 ZYC	1	
32		235725001	NUT - HEX - .38 - 16 - GR8 - YZ	1	

Rack-Lift Cylinder Fig 3-7

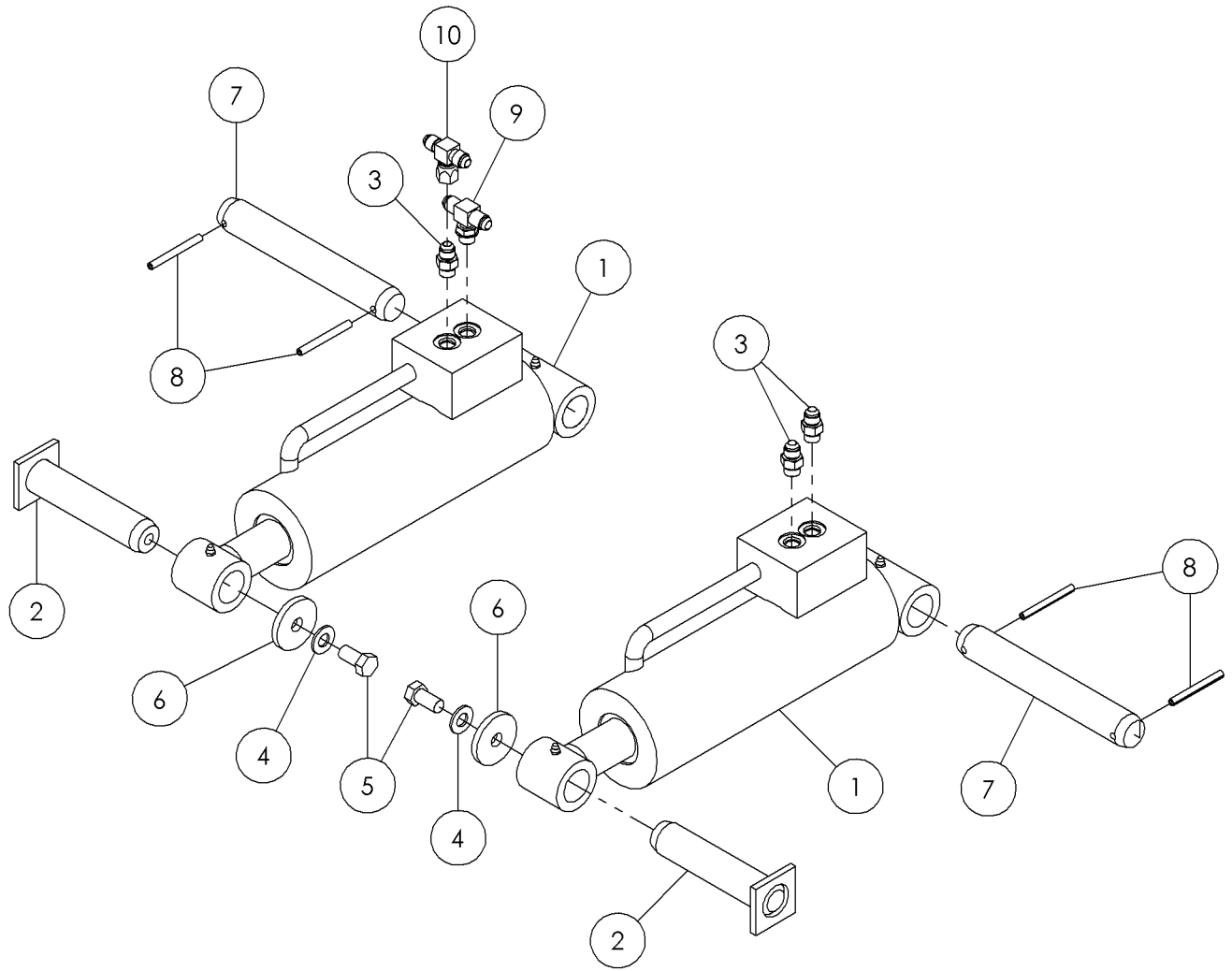
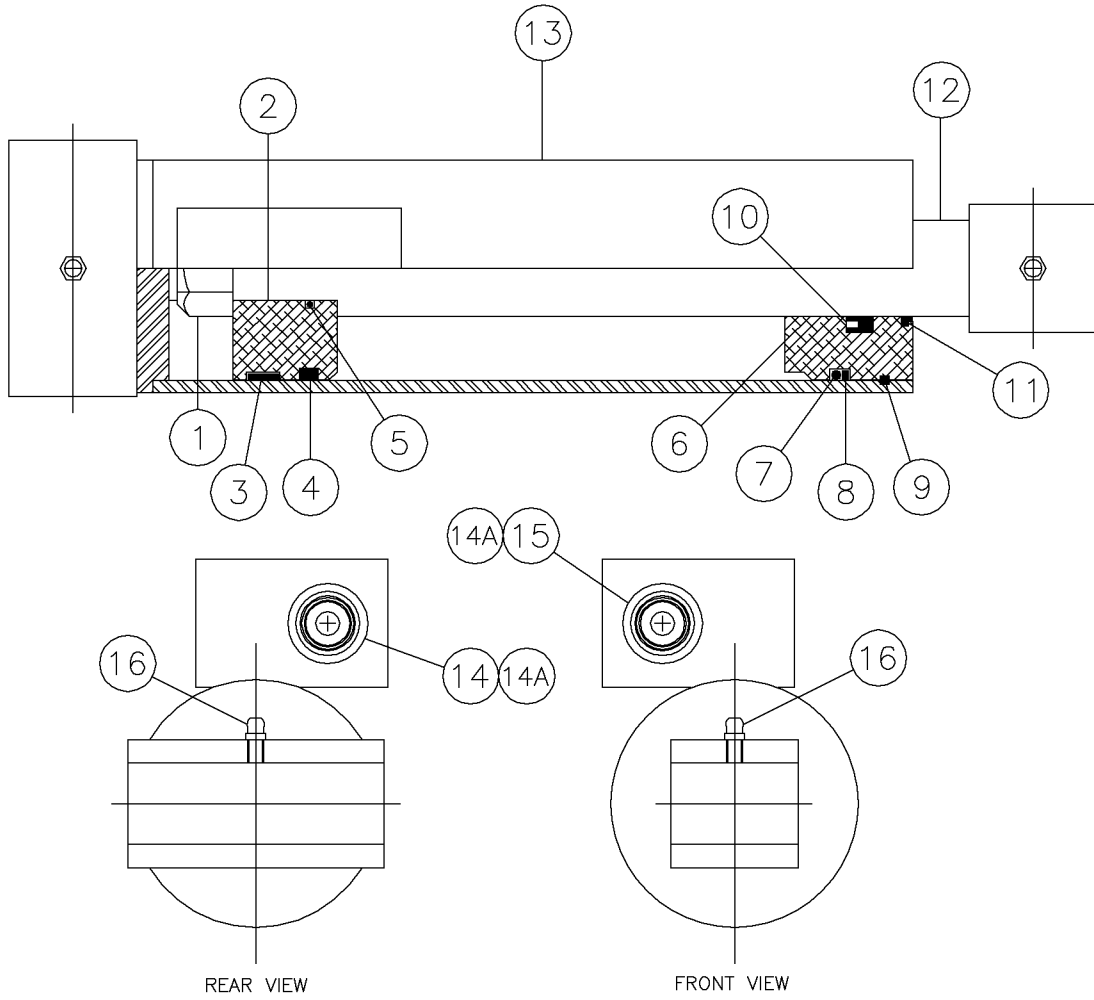

Illustration No. 296279927

## Rack-Lift Cylinder Fig 3-7

REF. NO.	*	PART NO.	DESCRIPTION	QTY.	REMARKS
1		278769001	CYLINDER-3 1/2"BORE X 7"STROKE	2	Breakdown Fig. 3-7z01
2		277202001	PIN-CYLINDER RACK	2	
3		65565001	FITTING - 6M O-RING X 6M JIC ST.	3	
4		485025	WASHER-1/2 FLAT-HARDENED-YZ	2	
5		235729001	SCREW-HCS-.50-13X1.00-GR8-YZ	2	
6		281787001	SLUG -.53 ID X 2.00 OD - 1/4"	2	
7		296277267	PIN - RACK CYLINDER PIN	2	
8		1788035	PIN-EXPANSION 1/4X2 1/2	4	
9		68787001	FITTING-6M (BCH)X6M JICX6M JIC	1	
10		60852001	6M JICX6FS JIC SWIV.NUT B TEE	1	

Components-Rack Lift Cylinder Fig 3-7z01



## Components-Rack Lift Cylinder Fig 3-7z01

REF. NO.	*	PART NO.	DESCRIPTION	QTY.	REMARKS
1		306011	NUT-1-14 SL PRINCE 220000210	1	
2		610291001	PISTON	1	
3		278769003	WEAR RING	1	
4		278769005	PSP SEAL	1	
5		278769007	O-RING	1	
6		278769009	HEAD	1	
7		278769011	O-RING	1	
8		278769013	BACKUP	1	
9		610292001	RETAINING RING	1	
10		236113021	POLYPAK	1	
11		236113023	DUST SEAL	1	
12		278769015	SHAFT W/ CLEVIS	1	
13		278769017	BARREL ASSEMBLY (W/O VALVE)	1	
14		117037001	VALVE	1	
14A		278769021	REPAIR KIT	2	
15		278769023	VALVE	1	
16		598001	FITTING-1/4" NF ST GREASE ZERK	2	
		278769001	CYLINDER-3 1/2"BORE X 7"STROKE	1	Includes All Items In Figure
		278769025	REPAIR KIT	1	Inc. Ref. 3-5, 7, 8, 10, & 11

Carriage Fig 3-8

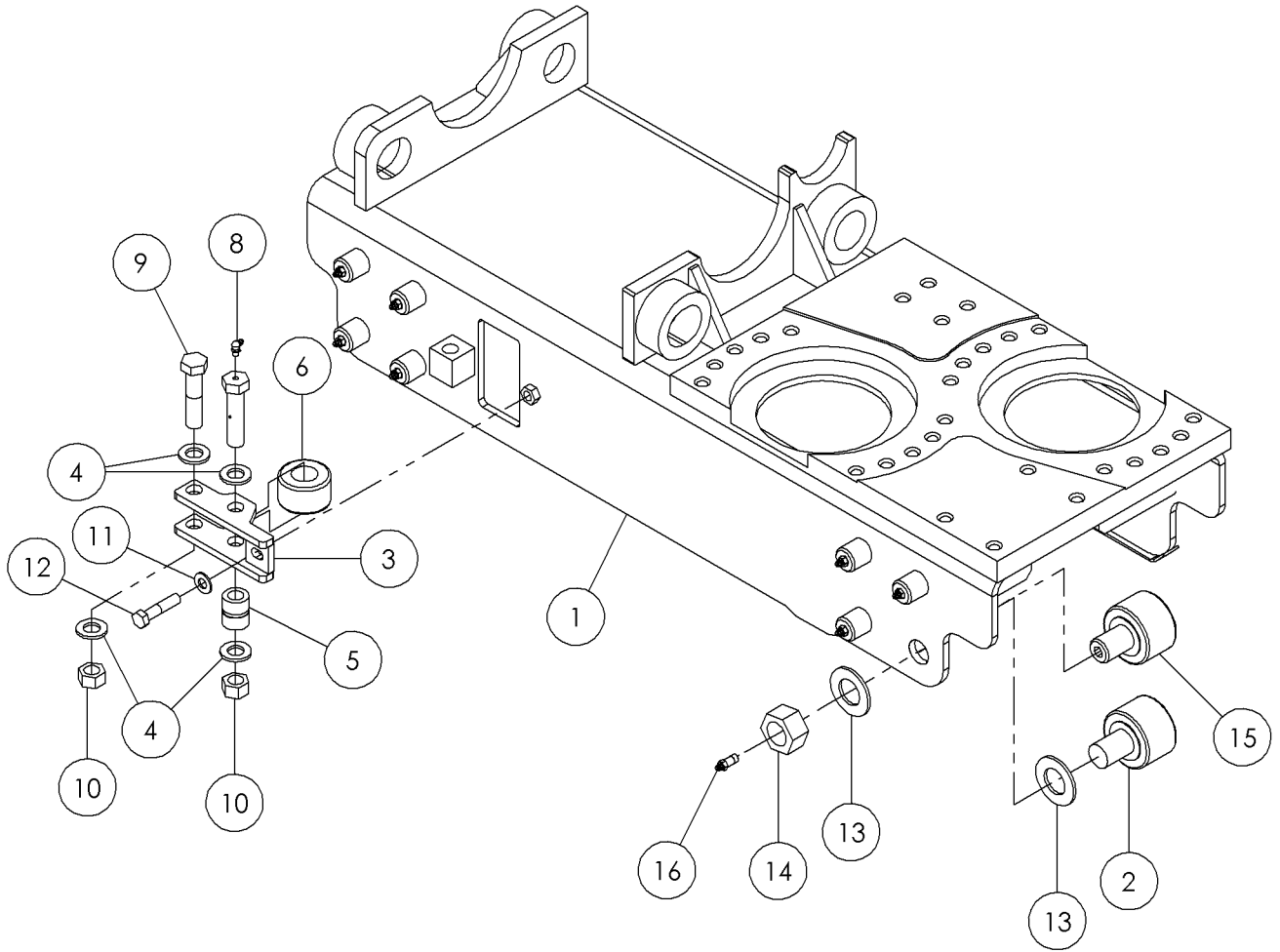
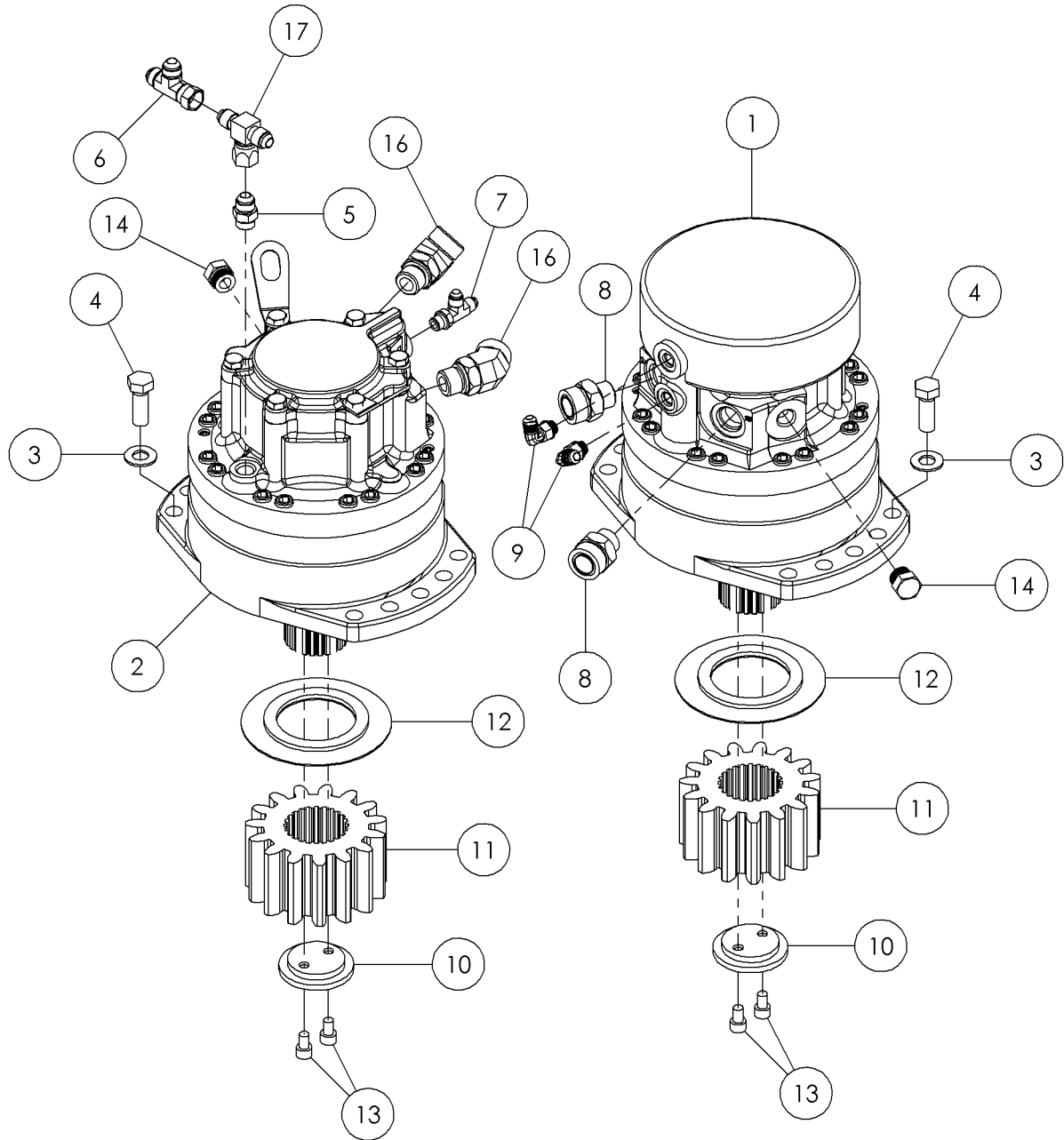

Illustration No. 296279865

## Carriage Fig 3-8

REF. NO.	*	PART NO.	DESCRIPTION	QTY.	REMARKS
1		296279987	CARRIAGE - GEARBOX THRUST	1	
2		296280155	ROLLER - 3"OD, 1 1/4-12 STUD	16	Greaseless Option
3		278875001	BRACKET - SIDE ROLLER	2	
4		235717001	WASHER - 3/4" HARDENED FLAT YZ	8	
5		244678001	BUSHING GUIDE ROLLER	2	
6		244679001	ROLLER-GUIDE	2	
7		235915001	BOLT-GREASABLE ROLLER 26184	2	
8		597001	ZERK-1/4" NF 90 DEG GREASE ZYC	2	
9		250604001	BOLT-3/4-10X3 1/4 GR8 HX Y/ZNC	2	
10		235739001	NUT-3/4-10 GR8 ZYC	4	
11		485025	WASHER-1/2 FLAT-HARDENED-YZ	2	
12		240335001	SCREW-HCS-.50-13X2.25-GR8-YZ	2	
13		238891001	WASHER-1 1/4 HARDENED FLAT ZY	32	
14		276475001	NUT - 1 - 1/4 - 12 HEX GR8 Y-ZINC	16	
15		296292059	ROLLER - 3.00 OD 1-1/4-12 STUD GREASABLE	16	Greaseable Option
16		592001	ZERK-1/8" ST GRSE (1 1/4" OA)	16	Greaseable Option

Thrust-Motor Fig 3-9





Thrust-Motor Fig 3-9

REF. NO.	*	PART NO.	DESCRIPTION	QTY.	REMARKS
1		278973001	MOTOR - 57.5 CID MS08 G W/ BRAKE	1	Breakdown Fig. 3-9z01
2		276258001	MOTOR-57.5 CI/REV MS08 D PREF	1	Breakdown Fig. 3-9z02
3		235715001	WASHER-FLATSTRL-5/8" YZ A325	20	
4		230728001	BOLT-5/8-11X1 3/4GR 8 PLATED	20	
5		53824001	FITTING-#8M O-RING-#8M JIC ST.	2	
6		59461001	8 JIC SW RUN TEE	1	
7		68774001	FITTING-6MX6M JIC (RUN)X6M JIC	1	
8		278957001	FITTING - 12 MOR X 16 MFFOR	2	
9		59426001	FITTING - 90-6MJ-6MORBA	2	
10		276320001	PLATE - PINION CAP	2	
11		276263001	GEAR - PINION THRUST PULLBACK	2	
12		296273636	WASHER - FOAM	2	
13		281779001	BOLT -M10X16MM SOC HD CAP SCREW	4	
14		56218001	FITTING - PLUG - 8MORB - HEX	2	
15		278926001	PLATE - LIFT POINT	2	
16		157809001	FITTING - 16-12 V5OLO	2	
17		63687001	8JIC FS BCHX8JIC MX8JIC M TEE	2	

Components-Thrust Motor/W Brake Fig 3-9z01

THERE IS THE POSSIBILITY OF HAVING TWO SIZES OF PISTONS IN A MOTOR. NORMALLY CL "0" IS USED. THERE IS NO MARKING ON THE PISTON OR CYLINDER BLOCK. THERE IS THE POSSIBILITY OF HAVING CL "1" WHICH IS 1mm OVER SIZE. THERE WILL BE A "1" STAMPED ON THE PISTON AND A CORRESPONDING "1" STAMPED ON THE CYLINDER BLOCK IN THE AREA OF THE EFFECTED CYLINDER BORE.

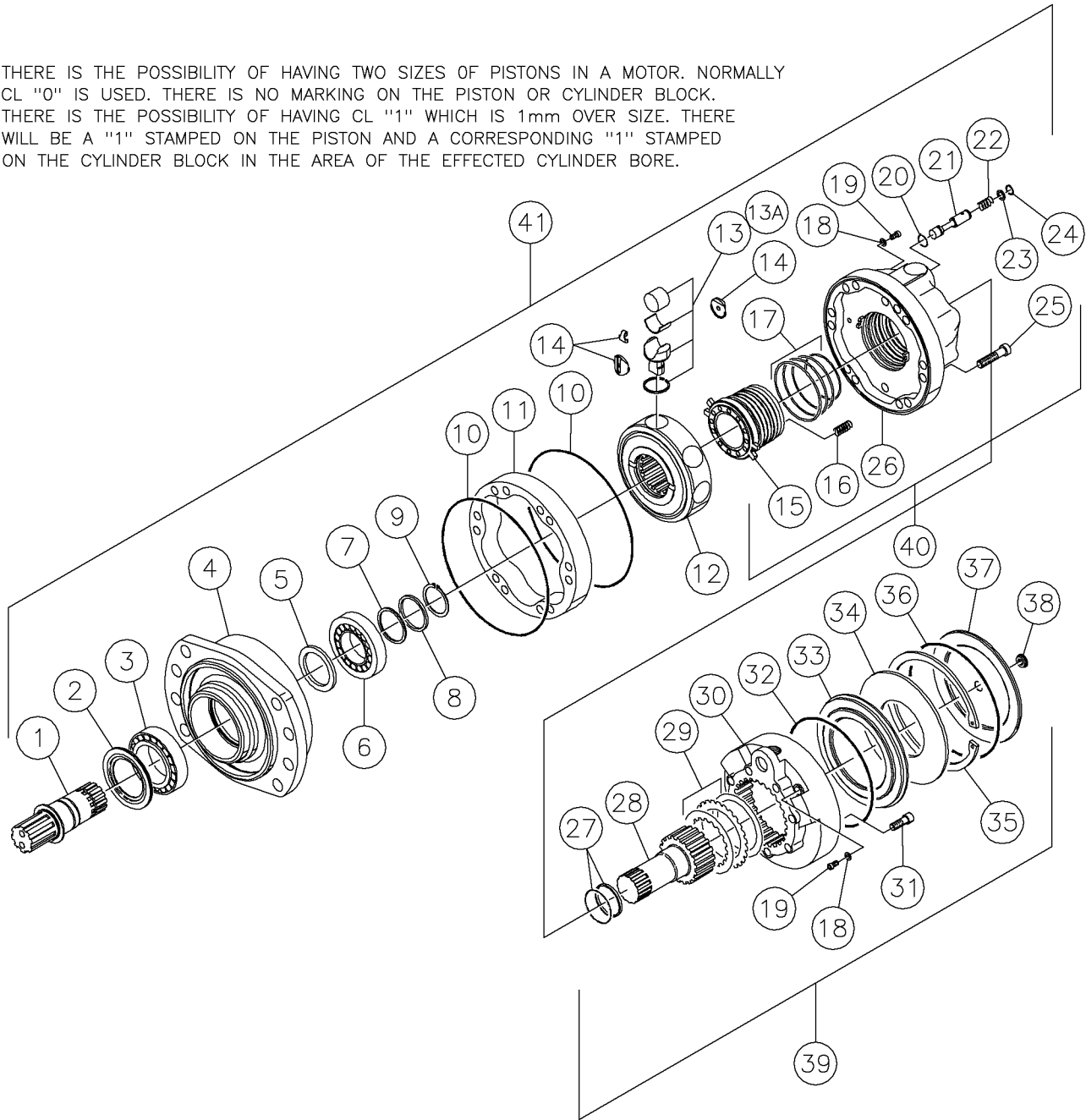

## Components-Thrust Motor/W Brake Fig 3-9z01

REF. NO.	*	PART NO.	DESCRIPTION	QTY.	REMARKS
1		276258009	SHAFT	1	
2		276258007	ENVIRONMENTAL SEAL	1	
3		905439009	OUTER BEARING	1	
4		276258005	BEARING SUPPORT	1	
5		208160001	INNER SHAFT SEAL	1	
6		208162001	INNER BEARING	1	
7		208163001	SHIM	1	
8		208164001	WASHER	1	
9		224897015	SNAP RING	1	
10		208152001	O-RING	2	
11		276258003	CAM RING	1	
12		224897003	CYLINDER BLOCK	1	Inc. Ref. 13 & 14
13		208148001	PISTON CL.1	A/R	
13A		224897005	PISTON CL "0"	A/R	
14		224897017	REPAIR KIT-PISTON	1	
15		235790009	VALVING	1	
16		84550029	SPRING	8	
17		208157001	VALVE SEAL RING	1	
18		64078025	WASHER	4	
19		64078027	SCREW-BLEEDING	4	
20		235790011	O-RING	1	
21		235790013	VALVE SPOOL	1	
22		235790015	SPRING	1	
23		235790017	WASHER	1	
24		235790019	SNAP RING	16	
25		235790007	SCREW	1	
26		235790005	VALVING COVER	1	
27		278973019	SEAL	1	
28		278973017	SHAFT	1	
29		278973021	BRAKE DISC KIT	1	
30		278973005	BRAKE BODY	1	
31		278973007	SCREW	8	
32		278973009	O-RING	1	
33		278973011	BRAKE PISTON	1	
34		278973013	SPRING WASHER	1	
35		278973015	SNAP RING	1	
36		278973025	O-RING	1	
37		278973027	PROTECTOR	1	
38		278973023	PLUG	1	
39		278973003	DISC BRAKE	1	Inc. Ref. 27-38
40		235790003	VALVING COVER ASSY	1	Inc. Ref. 15-26
41		278973001	MOTOR - 57.5 CID MSO8 G W/ BRAKE	1	Inc. All Items In Figure

Components-Thrust Motor Fig 3-9z02

THERE IS THE POSSIBILITY OF HAVING TWO SIZES OF PISTONS IN A MOTOR. NORMALLY CL "0" IS USED. THERE IS NO MARKING ON THE PISTON OR CYLINDER BLOCK. THERE IS THE POSSIBILITY OF HAVING CL "1" WHICH IS 1mm OVER SIZE. THERE WILL BE A "1" STAMPED ON THE PISTON AND A CORRESPONDING "1" STAMPED ON THE CYLINDER BLOCK IN THE AREA OF THE EFFECTED CYLINDER BORE.

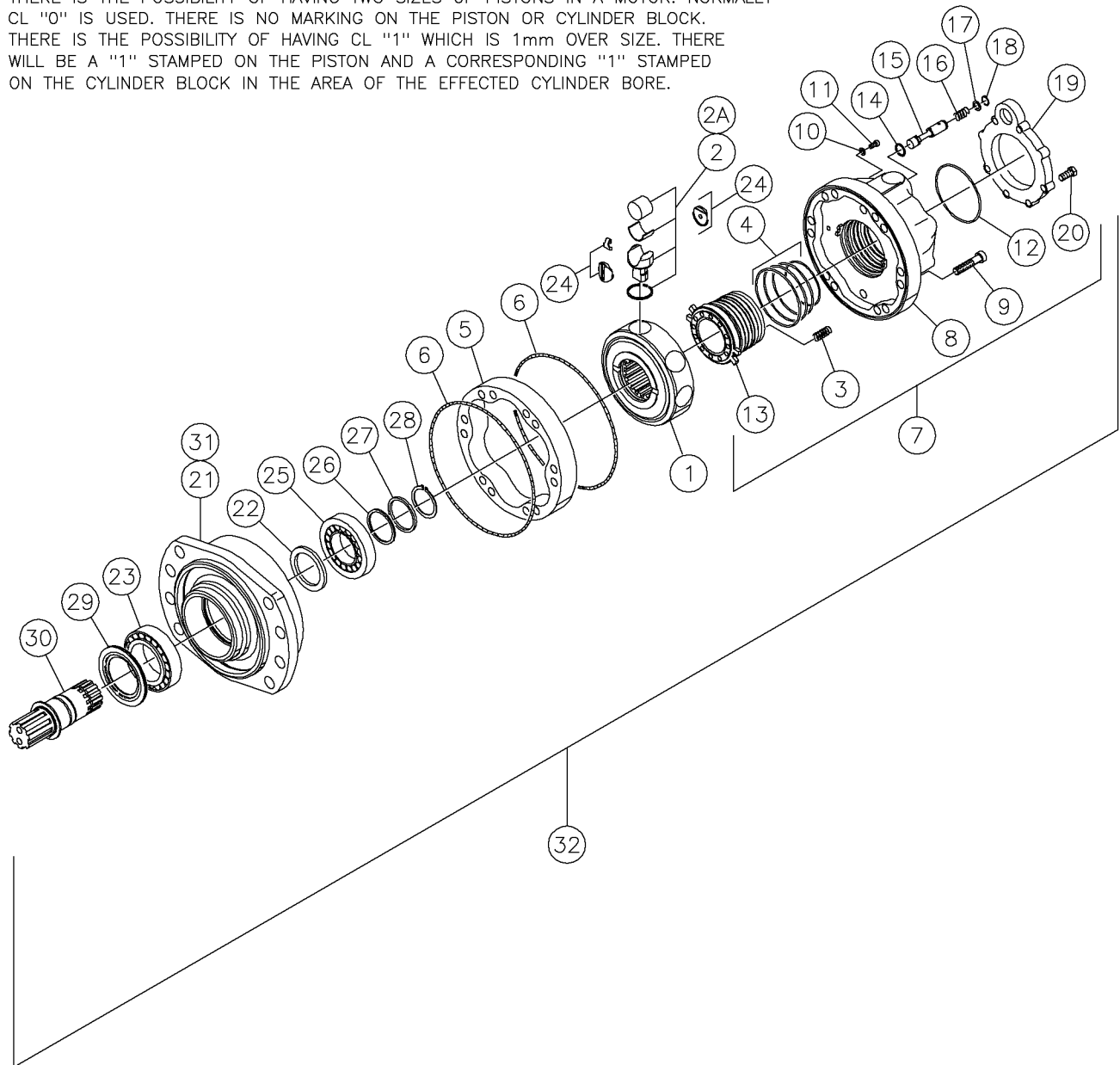

## Components-Thrust Motor Fig 3-9z02

REF. NO.	*	PART NO.	DESCRIPTION	QTY.	REMARKS
1		224897003	CYLINDER BLOCK	1	
2		208148001	PISTON CL.1	A/R	
2A		224897005	PISTON CL."O XCX	A/R	
3		84550029	SPRING	8	
4		208157001	VALVE SEAL RING	1	
5		276258003	CAM RING	1	
6		208152001	O-RING	2	
7		235790003	VALVE COVER ASSEMBLY	1	Inc. Ref. 3, 4, And 8-20
8		235790005	VALVING COVER	1	
9		235790007	SCREW	16	
10		64078025	WASHER	2	
11		64078027	SCREW-BLEEDING	2	
12		83651025	O-RING-2.62X145.72	1	
13		235790009	VALVING	1	
14		235790011	O-RING	1	
15		235790013	VALVE SPOOL	1	
16		235790015	SPRING	1	
17		235790017	WASHER	1	
18		235790019	SNAP RING	1	
19		235790021	BACK PLATE	1	
20		235790023	BOLT	6	
21		276258005	BEARING SUPPORT	1	
22		208160001	INNER SHAFT SEAL	1	
23		905439009	OUTER BEARING	1	
24		224897017	REPAIR KIT-PISTON	1	
25		208162001	INNER BEARING	1	
26		208163001	SHIM	1	
27		208164001	WASHER	1	
28		224897015	SNAP RING	1	
29		276258007	ENVIRONMENTAL SEAL	1	
30		276258009	SHAFT	1	
31		276258011	BEARING SUPPORT ASSEMBLY	1	Inc. Ref. 21-23 And 25-30
32		276258001	MOTOR-57.5 CI/REV MS08 D PREF	1	Inc. All Items In Figure

Thrust-Valve Fig 3-10

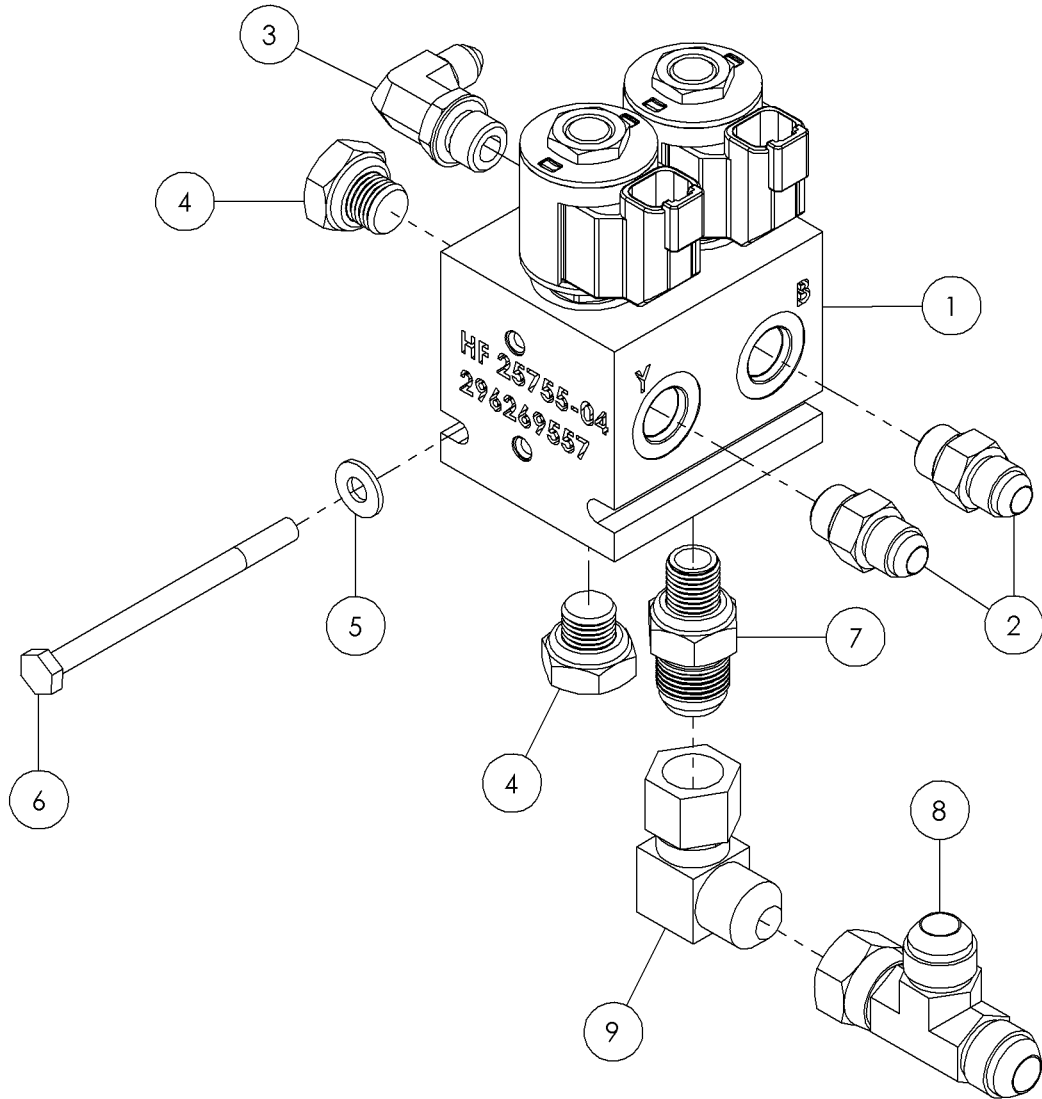

## Thrust-Valve Fig 3-10

REF. NO.	*	PART NO.	DESCRIPTION	QTY.	REMARKS
1		296269557	VALVE- TWO SPEED W/BRAKE	1	Breakdown Fig. 3-10z01
2		65565001	FITTING - 6M O-RING X 6M JIC ST.	2	
3		57950001	FITTING-90-4MJ-6MORBA	1	
4		5553001	FITTING - PLUG - 6MORB - HEX	2	
5		235716001	WASHER-FLATSTRL-.25-.28X.63-.06-CZ	2	
6		244204001	SCREW-HCS-.25-20X3.50-GR8-YZ-SP	2	
7		86235001	6M ORING X 8M JIC STR.	1	
8		59461001	8 JIC SW RUN TEE	1	
9		59405001	8M JICX8FS JIC 90 DEG.ELBOW	1	

Components-Thrust Valve Fig 3-10z01

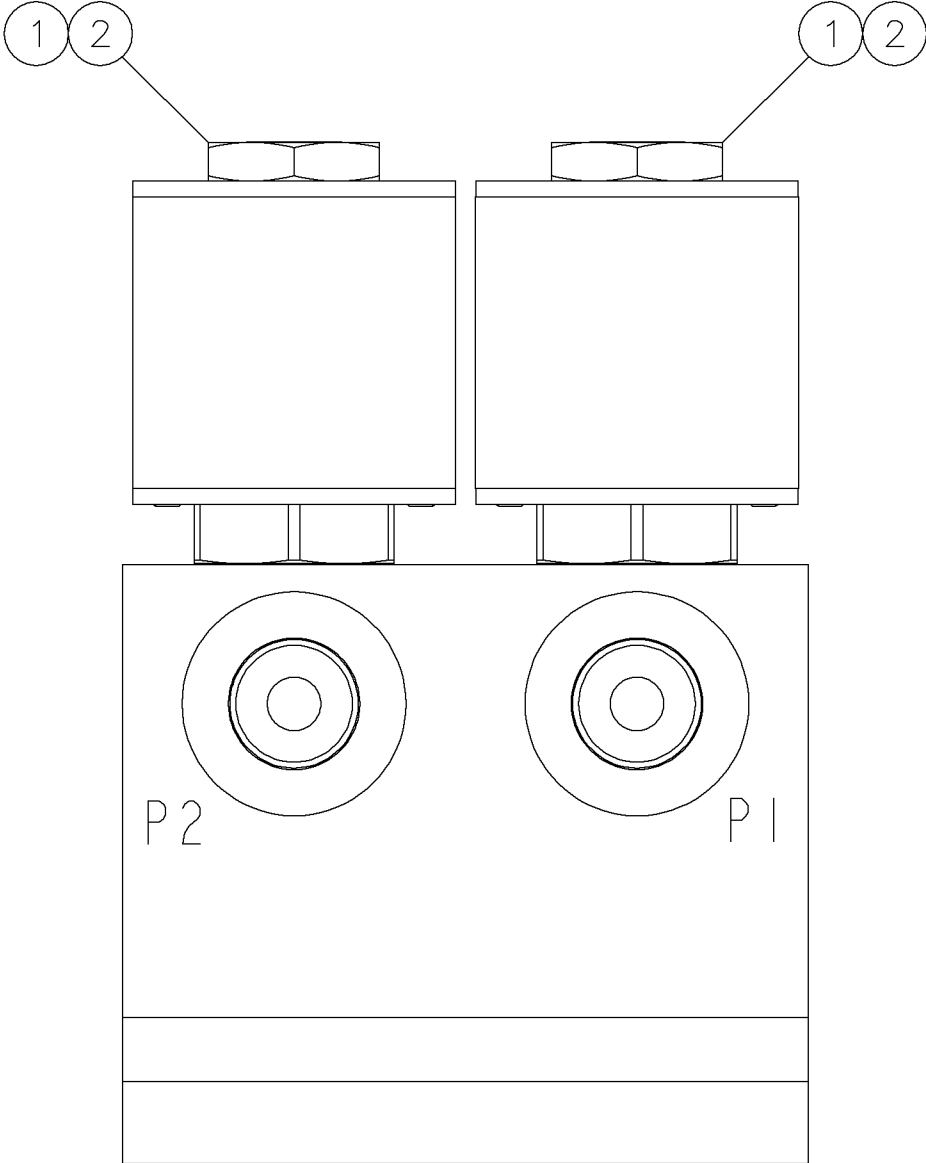



## Components-Thrust Valve Fig 3-10z01

REF. NO.	*	PART NO.	DESCRIPTION	QTY.	REMARKS
1		296272930	SOLENOID VALVE	2	
1		161159001	SEAL KIT	2	
2		296271115	COIL	2	
2		244725007	NUT - COIL	2	
		296272931	PLUG	2	Not Shown
		296269557	VALVE- TWO SPEED W/BRAKE		Includes All Items In Figure

Gearbox Fig 3-11

Illustration No. 296279979

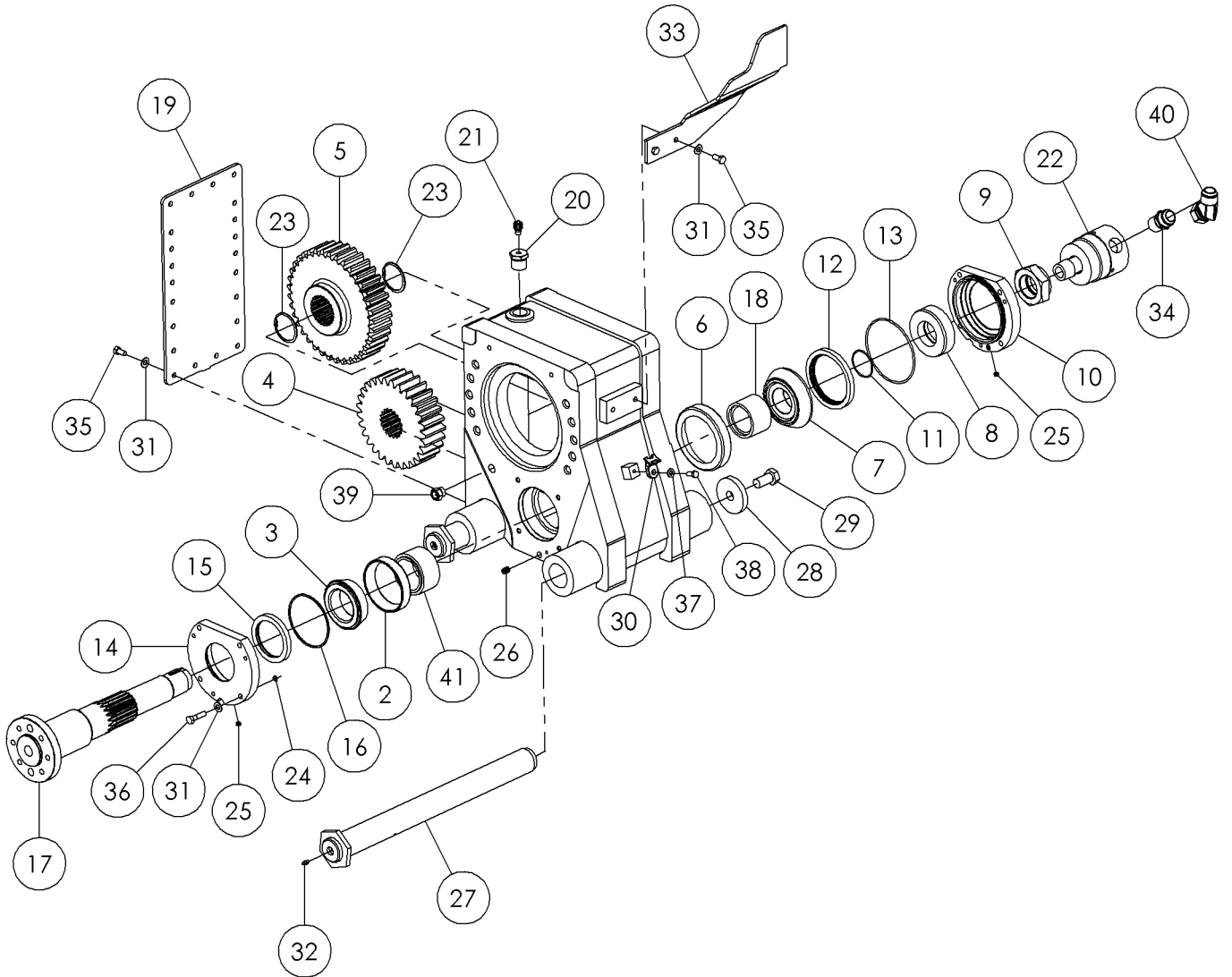

## Gearbox Fig 3-11

REF. NO.	*	PART NO.	DESCRIPTION	QTY.	REMARKS
1		296280752	GEARBOX - ROTATION (MACH)	1	
2		1715013	TIMKEN CUP-2 1/2" #3920	1	
3		4771061	BRG. CONE 3994	1	
4		251223001	GEAR - 29 TOOTH 2.25 FACE	1	
5		296279983	GEAR - 37T - 4DP	1	
6		1715085	CUP-BEARING	1	
7		1716099	CONE-2 1/8" BRG.	1	
8		215350001	SLEEVE-SEAL	1	
9		278767001	NUT - 50X18-4000# SPEITH-LOCK	1	
10		296279996	GLAND - REAR SEAL	1	
11		214202001	O-RING #138	1	
12		296273549	SEAL-4.000"-LIP	1	
13		228180001	O-RING -#252 7OD BUNA-N	1	
14		296279995	GLAND - FRONT SEAL	1	
15		296273548	SEAL-3. 125"-LIP	1	
16		228181001	O-RING -#243 7OD BUNA-N	1	
17		296303814	SHAFT-ROTATION	1	
18		296279994	SPACER - GEARBOX	1	
19		296280755	COVER - REMOVABLE GEARBOX	1	
20		296273639	FITTING - 16MNPT - 2FNPT - HEX -YZ	1	
21		599001	BREATHER VENT-1/8 NPT 131000	1	
22		276390001	SWIVEL-1"NPT1500#1250RPM/46PGM	1	
23		296273519	SNAP RING (HO-237)	2	
24		78185027	O-RING # 407228	2	
25		296292056	1/16 FLUSH HOLLOW HEX PLUG	2	
26		78202001	PLUG-1/4NPT SOCKET HEAD PIPE	1	
27		296271254	PIN - FLOATING HEAD	2	
28		296265249	PLATE - WASHER	2	
29		238217001	BOLT-3/4-10X1 1/2 GR8 HEX ZYC	2	
30		296276018	MOUNT HELLER MANN TITON	1	
31		235713001	WASHER-FLATSTRL-.38-.41X.81-.06-YA-A325	31	
32		598001	FITTING-1/4" NF ST GREASE ZERK	2	
33		296280172	PLATE - INDICATOR ARM	1	
34		59269001	1 NPTX16 JIC ST ADAPTER	1	
35		235726001	BOLT-3/8-16X3/4 GR8 HEX ZNCPLT	24	
36		235723001	SCREW - HCS -.38 - 16 X 1.50 - GR8 - YZ	6	
37		235714001	WASHER-FLATSTRL-.31-.34X.69-.06-YZ-A325	1	
38		235742001	BOLT-5/16-18X3/4 GR8 ZYC	1	
39		613754001	PLUG - SIGHT .75-16 ZC	1	
40		61702001	16M JIC X 16FS JIC 45	1	
41		296303813	SPACER - FRONT GEARBOX	1	

Rotation-Motor Fig 3-12

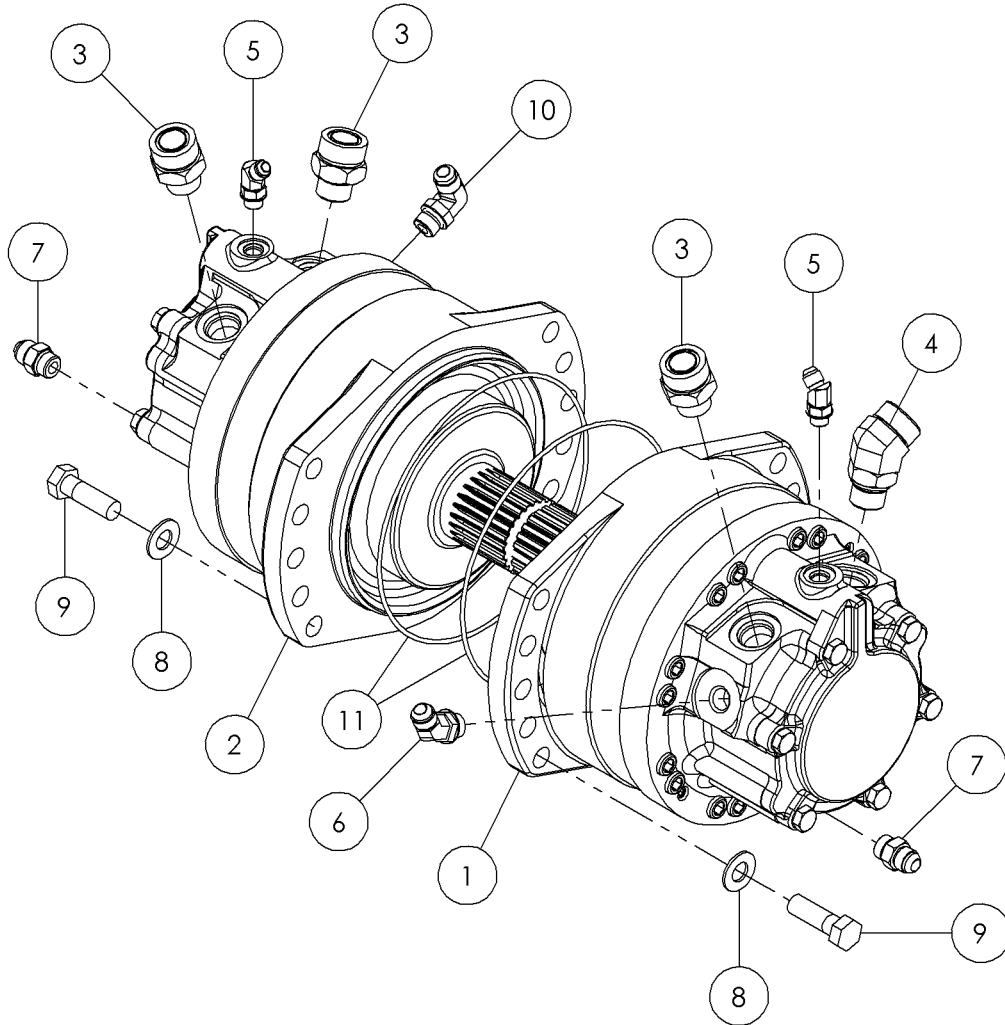
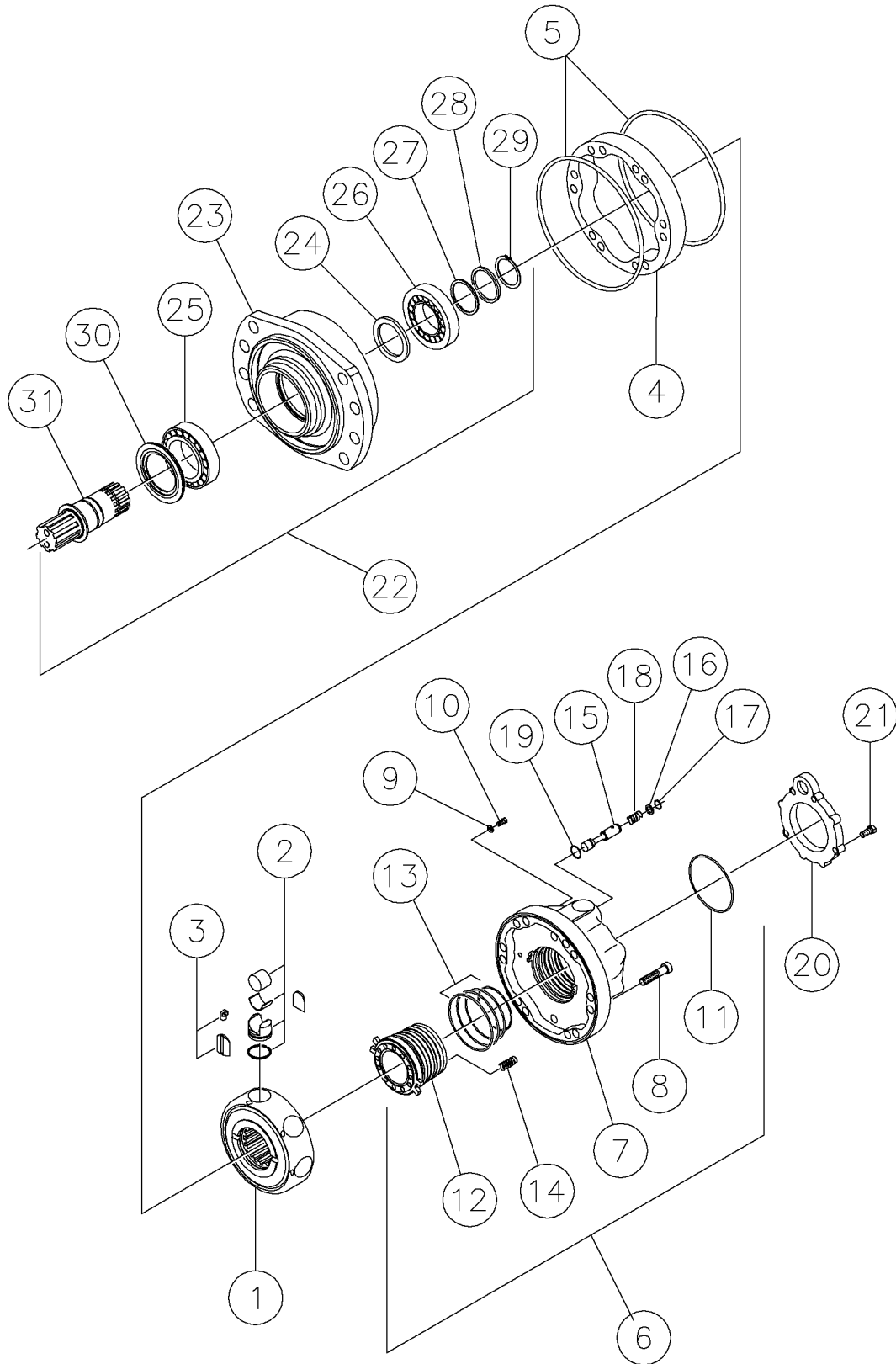

Illustration No. 296279914

## Rotation-Motor Fig 3-12

REF. NO.	*	PART NO.	DESCRIPTION	QTY.	REMARKS
1		296279981	MOTOR - HYD MS08 - 9 D	1	Breakdown Fig. 3-12z01
2		296279982	MOTOR - HYD MS08 - P G	1	Breakdown Fig. 3-12z02
3		278957001	FITTING - 12 MOR X 16 MFFOR	3	
4		157809001	FITTING - 16-12 V5OLO	1	
5		65563001	FITTING - 6M O-RING X 6M JIC 45 DEGREE	2	
6		53834001	#8M O-RING-#8M JIC 45 DEG.	2	
7		53824001	FITTING-#8M O-RING-#8M JIC ST.	2	
8		235715001	WASHER-FLATSTRL-5/8" YZ A325	20	
9		145645001	BOLT - 5/8 - 11 X 2 GR.8 ZYC	20	
10		53837001	FITTING - 8M O-RING X 8M JIC 90 DEGREE	1	
11		280763001	O-RING #266	2	

Components-Rotation Motor Fig 3-12z01



## Components-Rotation Motor Fig 3-12z01

REF. NO.	*	PART NO.	DESCRIPTION	QTY.	REMARKS
1		224897003	CYLINDER BLOCK	1	Inc. Ref. 2-3
2		224897005	PISTON CL "0"	1	Inc. Two Of Ref. 5
3		224897017	REPAIR KIT-PISTON	1	
4		296278023	CAM RING	1	
5		256555021	O-RING	2	
6		296278024	VALVING COVER ASSEMBLY	1	Inc. Ref. 7-19
7		235790005	VALVING COVER	1	
8		235790007	SCREW	16	
9		608383001	WASHER	2	
10		140255041	SCREW - BOLT	2	
11		608385001	O-RING	1	
12		296278025	VALVING	1	
13		256555027	SEAL KIT	1	
14		84550029	SPRING	8	
15		235790013	VALVE SPOOL	1	
16		235790017	WASHER	1	
17		235790019	SNAP RING	1	
18		235790015	SPRING	1	
19		235790011	O-RING	1	
20		235790021	BACK PLATE	1	Inc. Six Of Ref. 21
21		235790023	BOLT	6	
22		276258011	BEARING SUPPORT ASSEMBLY	1	Inc. Ref. 23-31
23		276258005	BEARING SUPPORT	1	
24		256555011	RUBBER SEAL RING	1	
25		256555007	BEARING	1	
26		256555013	BEARING	1	
27		256555015	SET OF SPUDS	1	
28		256555017	RING	1	
29		208165001	SNAP RING	1	
30		256555005	ENVIRONMENT SEAL	1	
31		276258009	SHAFT	1	
		296272979	SEAL KIT	1	
		256555029	SEAL KIT	1	
		296279981	MOTOR - HYD MS08 - 9 D		Includes All Items In Figure

Components-Rotation Motor Fig 3-12z02

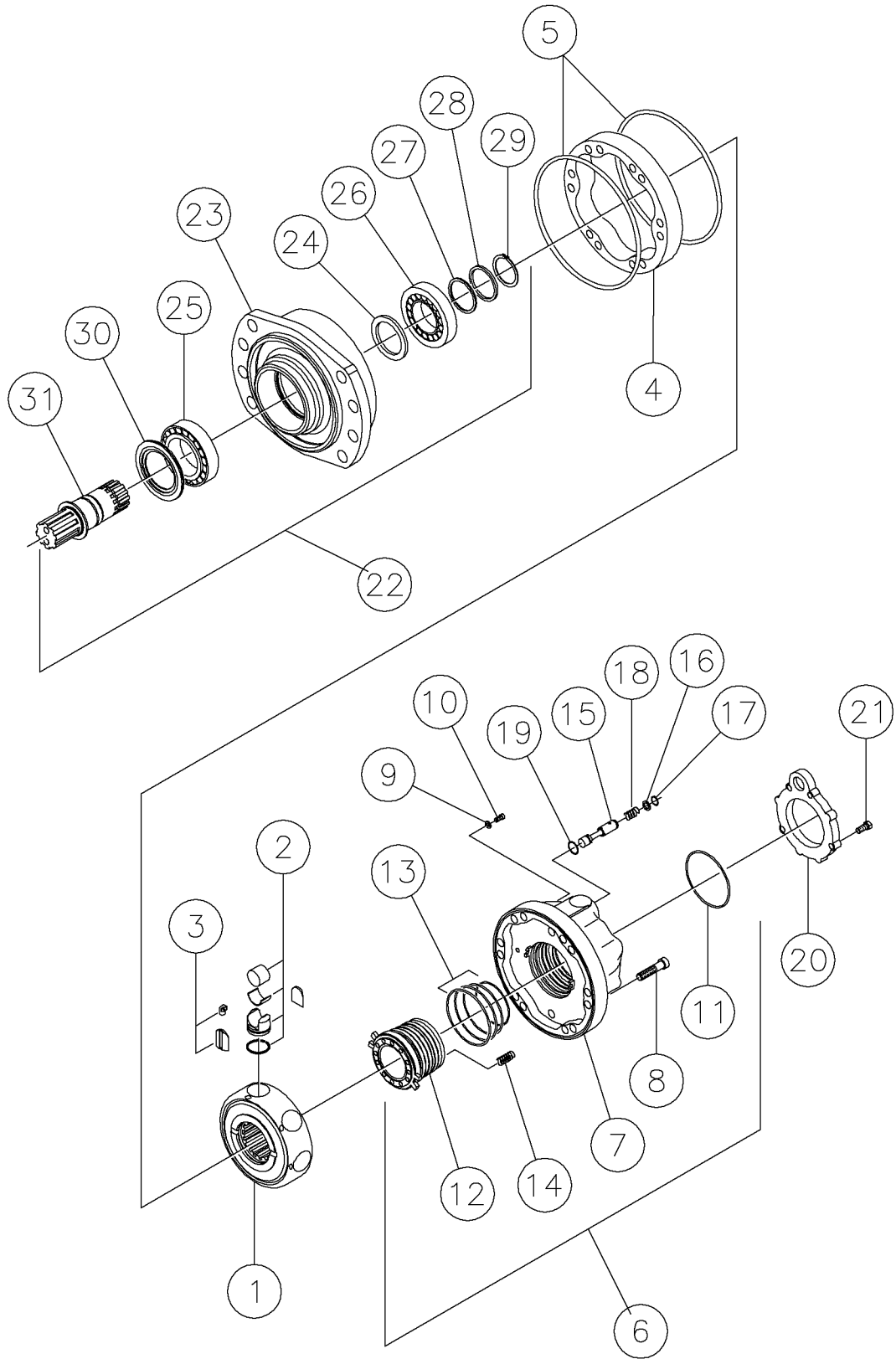



## Components-Rotation Motor Fig 3-12z02

REF. NO.	*	PART NO.	DESCRIPTION	QTY.	REMARKS
1		224897003	CYLINDER BLOCK	1	Inc. Ref. 2-3
2		224897005	PISTON CL "0"	1	Inc. Two Of Ref. 5
3		224897017	REPAIR KIT-PISTON	1	
4		296278023	CAM RING	1	
5		256555021	O-RING	2	
6		296278024	VALVING COVER ASSEMBLY	1	Inc. Ref. 7-19
7		235790005	VALVING COVER	1	
8		235790007	SCREW	16	
9		608383001	WASHER	2	
10		140255041	SCREW - BOLT	2	
11		608385001	O-RING	1	
12		296278025	VALVING	1	
13		256555027	SEAL KIT	1	
14		84550029	SPRING	8	
15		235790013	VALVE SPOOL	1	
16		235790017	WASHER	1	
17		235790019	SNAP RING	1	
18		235790015	SPRING	1	
19		235790011	O-RING	1	
20		235790021	BACK PLATE	1	Inc. Six Of Ref. 21
21		235790023	BOLT	6	
22		276258011	BEARING SUPPORT ASSEMBLY	1	Inc. Ref. 23-31
23		276258005	BEARING SUPPORT	1	
24		256555011	RUBBER SEAL RING	1	
25		256555007	BEARING	1	
26		256555013	BEARING	1	
27		256555015	SET OF SPUDS	1	
28		256555017	RING	1	
29		208165001	SNAP RING	1	
30		256555005	ENVIRONMENT SEAL	1	
31		276258009	SHAFT	1	
		296272979	SEAL KIT	1	
		256555029	SEAL KIT	1	
		296279982	MOTOR - HYD MS08 - P G		Inc. All Items In Figure

Drive Chuck Fig 3-12x01

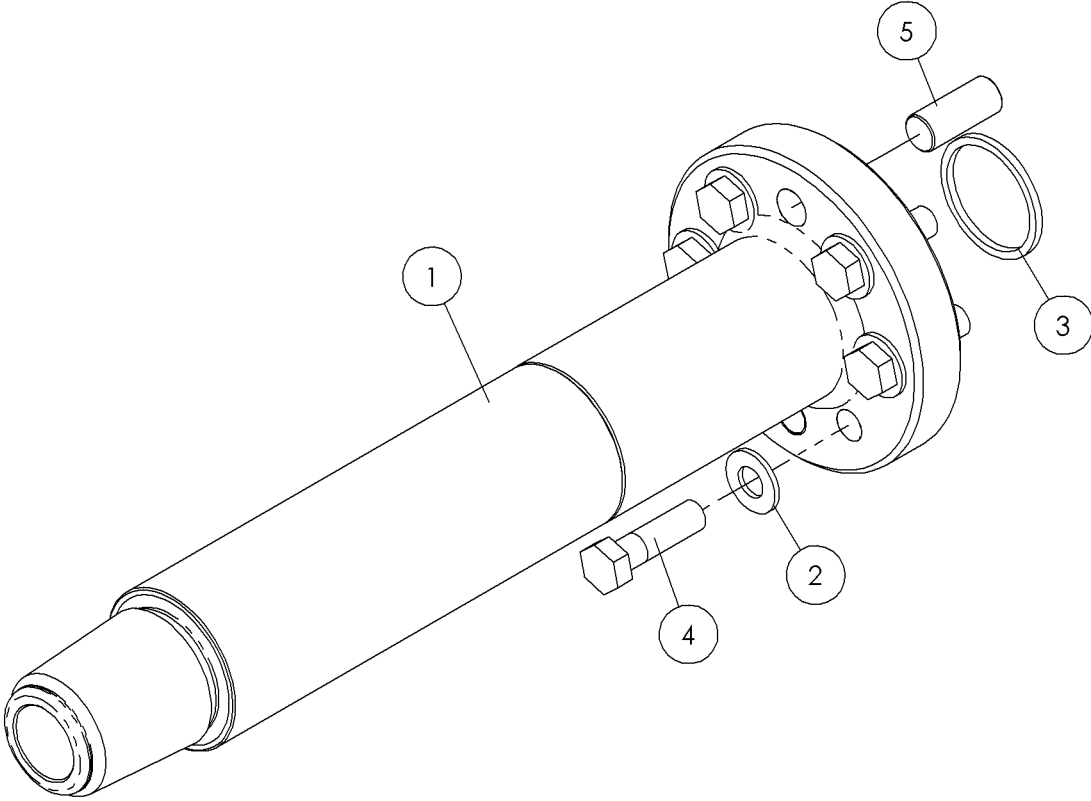

## Drive Chuck Fig 3-12x01

REF. NO.	*	PART NO.	DESCRIPTION	QTY.	REMARKS
1		296309505	DRIVE CHUCK ASSY-2.625 FST-1 THRD X 5.5 FLG X 14.42	1	Breakdown Fig. 3-12x01z01
1		296309648	DRIVE CHUCK ASSY #650 2.375FST-I THRD X 5.5X16.0	1	Breakdown Fig. 3-12x01z01
2		485025	WASHER-1/2 FLAT-HARDENED-YZ	6	
3		72897001	O RING-SQ. #24 FLANGE	1	
4		240334001	SCREW-HCS-.50-13X1.75-GR8-YZ	6	
5		70096001	PIN-DOWEL 5/8DIA.-1 1/2	2	

Components-Drive Chuck Fig 3-12x01z01

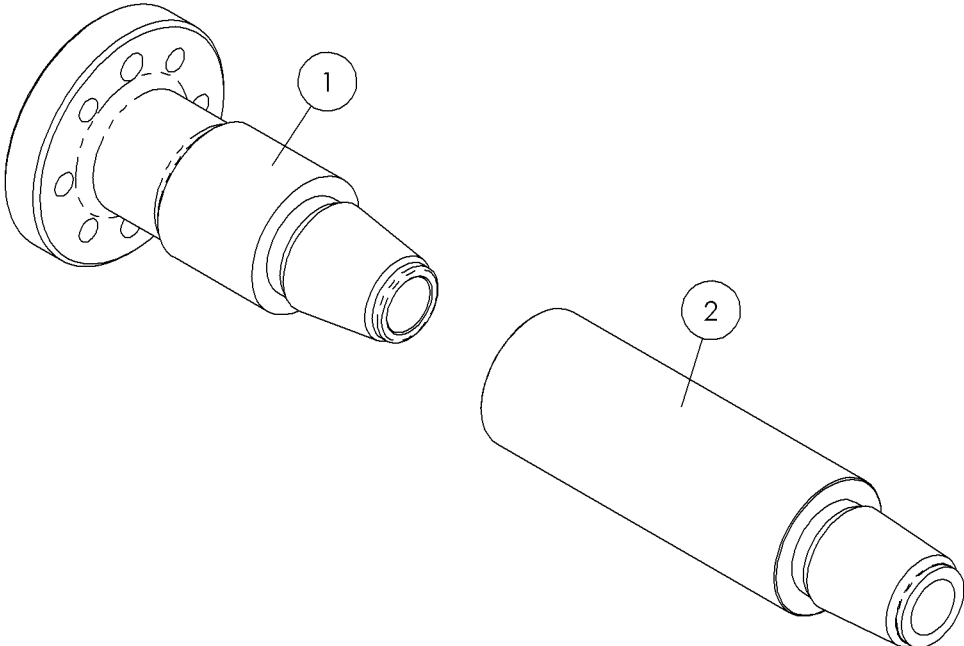

Illustration No. 296309505

## Components-Drive Chuck Fig 3-12x01z01

REF. NO.	*	PART NO.	DESCRIPTION	QTY.	REMARKS
1		296309506	DRIVE CHUCK-MCHND 2.625 FS1 THRD X 5.5 FLGX6.0	1	
1		296309649	DRIVE CHUCK - MACHINED #650 2.375 5.5.X6.5	1	
2		296309507	SHAFT-SUB SAVER 2.625 FS1 THRD X 8.5L	1	
2		296309650	SHAFT - SUBSAVER #650 2.375 X9.5	1	

Operator Platform Fig 3-13

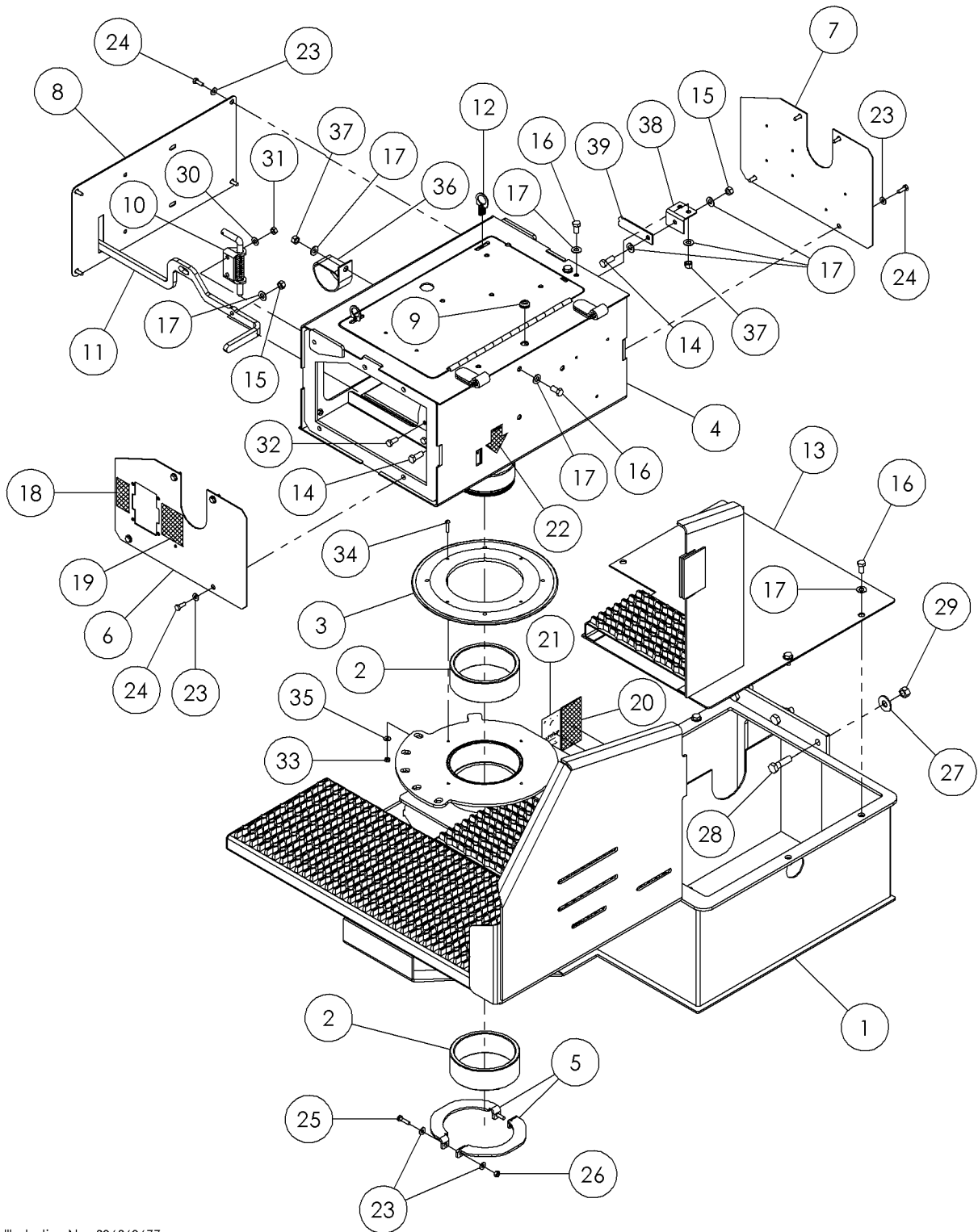

Illustration No. 296269677

## Operator Platform Fig 3-13

REF. NO.	*	PART NO.	DESCRIPTION	QTY.	REMARKS
1		296269678	WELDMENT - OPERATOR PLATFORM	1	
2		296274302	BUSHING - PIVOT	2	
3		296256466	BEARING-LAZY SUSAN #12C	1	
4		296287814	WELDMENT - CONSOLE LOWER FRAME	1	
5		296274303	CLAMP - SHAFT CLAMP CONSOLE LOWER BASE	2	
6		296287821	PLATE - SIDE CONSOLE FRAME RH	1	
7		296287823	PLATE - SIDE CONSOLE FRAME LH	1	
8		296282509	PLATE - COVER SEAT BASE	1	
9		1865027	GROMMET-5/16ID-1/8GR-.56 HOLE	1	
10		296274337	SPRING LATCH 720-S-L-ZINC	1	
11		296287824	LEVER - SEAT LOCK RELEASE	1	
12		86113001	FASTENER-1/4 TURN	2	
13		296269689	PANEL - BATTERY COVER	1	
14		235727001	SCREW-HCS-.38-16X1.00-GR8-YZ	2	
15		250508001	NUT - 3/8-NC Gr8 TOP LOCK Y/ZINC	2	
16		235726001	BOLT-3/8-16X3/4 GR8 HEX ZNCPLT	7	
17		235713001	WASHER - FLATSTRL - .38 - .41 X .81 - .06-YA-A325	13	
18		7000C928	DECAL-RELAY BOX 2/CONTROLLERS	1	
19		7000C687	DECAL-BREAKER BOX D36X50	1	
20		7000C446	DECAL - NO WELD	1	Domestic
		700IC446	DECAL - NO WELD	1	International
21		70000044	DECAL-WARNING(AT/UND)	1	Domestic
		7000I044	DECAL-WARNING	1	International
22		700IB248	DECAL - PUSH	2	
23		235716001	WASHER - FLATSTRL - .25 -.28 X .63 - .06 - CZ	16	
24		235734001	BOLT-1/4-20X3/4 GR8 ZYC	12	
25		235735001	BOLT-1/4-20X1 GR8 HEX ZYC	2	
26		248198001	NUT-1/4 - 20 GR8 TOP LOCK ZINC	2	
27		510337611	WASHER - FLATSTD - .50-.56X1.38-.11- YZ	6	
28		240334001	SCREW-HCS-.50-13X1.75-GR8-YZ	6	
29		250512001	NUT- 1/2 NC Gr8 TOP LOCK Y/ ZINC	6	
30		235714001	WASHER - FLATSTRL - .31 - .34 X .69 - .06-YZ-A325	2	
31		235741001	NUT - HEX - .31 - 18 - GR8 -YZ	2	
32		235742001	BOLT-5/16-18X3/4 GR8 ZYC	2	
33		400001	NUT-3/16 NC HEX	3	
34		1802010	SCREW-MCH-10-24X1.00-GR2-CZ-ROUND-SLTD	3	
35		510337601	WASHER-FLATSTD-.19-.22X.56-.05-YZ	3	
36		278901001	STRAP - HOSE SLEEVE HANGER	1	
37		235725001	NUT - HEX - .38 - 16 - GR8 - YZ	3	
38		296292020	PLATE - PROP ROD	1	
39		296292019	PROP ROD - CONSOLE	1	

Control Console Fig 3-14

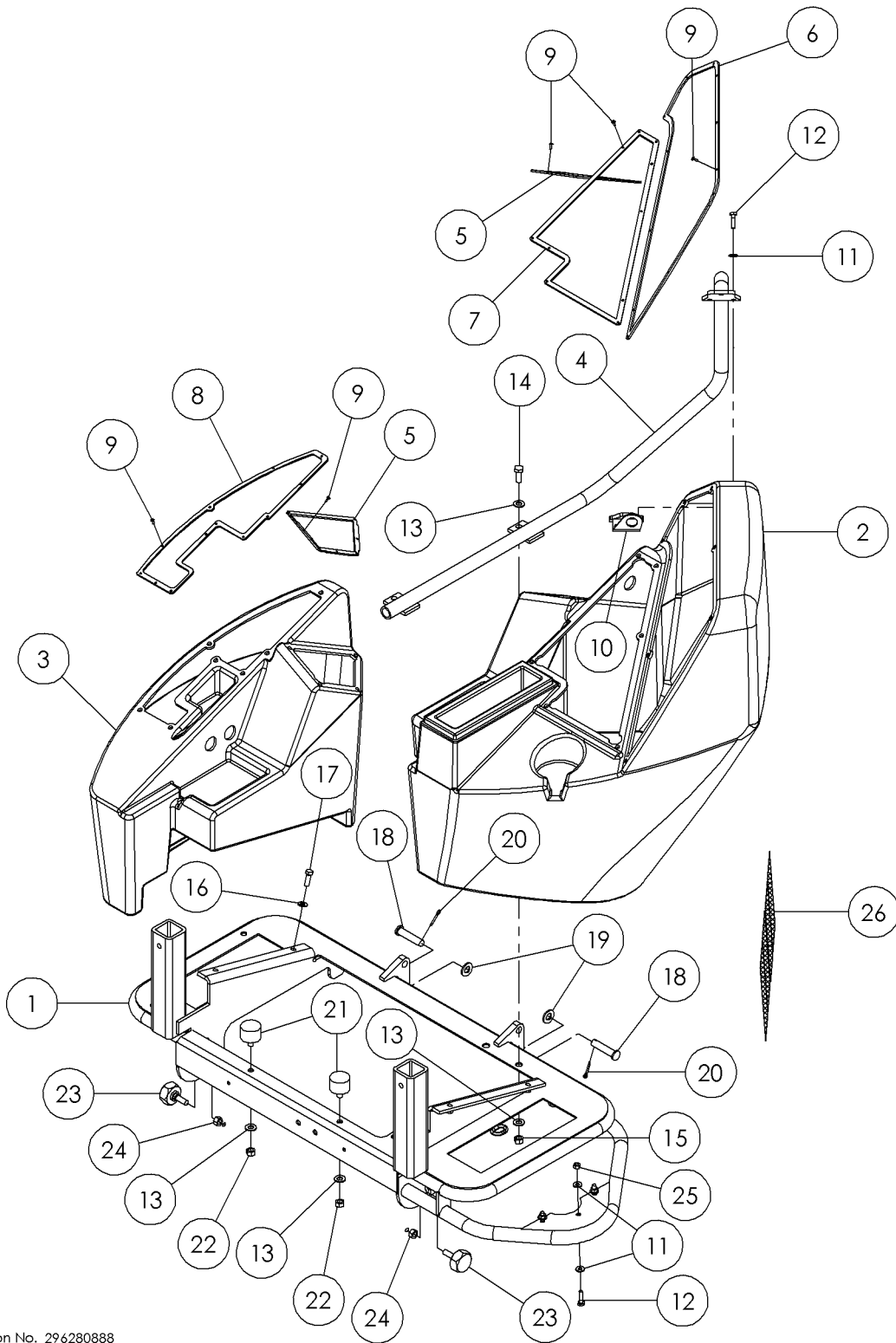

Illustration No. 296280888



## Control Console Fig 3-14

REF. NO.	*	PART NO.	DESCRIPTION	QTY.	REMARKS
1		296287827	FRAME - SEAT WELDMENT STANDARD OPER CONSOLE	1	
2		296274251	CONSOLE - OPERATOR RH	1	
3		296274252	CONSOLE - OPERATOR LH	1	
4		296274172	WELD - HAND RAIL	1	
5		296274182	BACKING - PLATE - JOYSTICK	2	
6		296274187	PLATE - BACKING GAUGE RIGHT UPPER	1	
7		296274188	BACKING - PLATE RIGHT HAND LOWER	1	
8		296274190	PLATE - BACKING LEFT HAND	1	
9		296280370	POP RIVET - ABA46	19	
10		296274185	WELDMENT-MOUNT-ANTENNA/HANDLE	1	
11		235716001	WASHER - FLATSTRL - .25 - .28 X .63 - .06 - CZ	9	
12		235735001	BOLT-1/4-20X1 GR8 HEX ZYC	6	
13		235713001	WASHER - FLATSTRL - .38 - .41 X .81 - .06-YA-A325	6	
14		235727001	SCREW-HCS-.38-16X1.00-GR8-YZ	2	
15		250508001	NUT - 3/8-NC Gr8 TOP LOCK Y/ZINC	2	
16		235714001	WASHER - FLATSTRL - .31 - .34 X .69 - .06-YZ-A325	4	
17		238209001	BOLT-5/16-18X1 GR8 HEX ZINC YC	4	
18		289662001	PIN - CLEVIS 1/2" X 2 1/4"	2	
19		485025	WASHER-1/2 FLAT-HARDENED-YZ	2	
20		510009	COTTER PIN-1/8" X 1" REF TR00317	2	
21		122474001	MOUNT-SANDWICH SINGLE STUD	2	
22		235725001	NUT - HEX - .38 - 16 - GR8 - YZ	2	
23		296274127	HANDLE - SEAT ADJUSTMENT	2	
24		416001	NUT-3/8 NC SLTL REF T13409	2	
25		248198001	NUT-1/4 - 20 GR8 TOP LOCK ZINC	3	
26		7000C530	DECAL - DANGER 4 PANEL	1	Domestic
26		700IC530	DECAL - DANGER INTERNATIONAL 4 PANEL	1	International

Seat/Arm Rest Fig 3-15

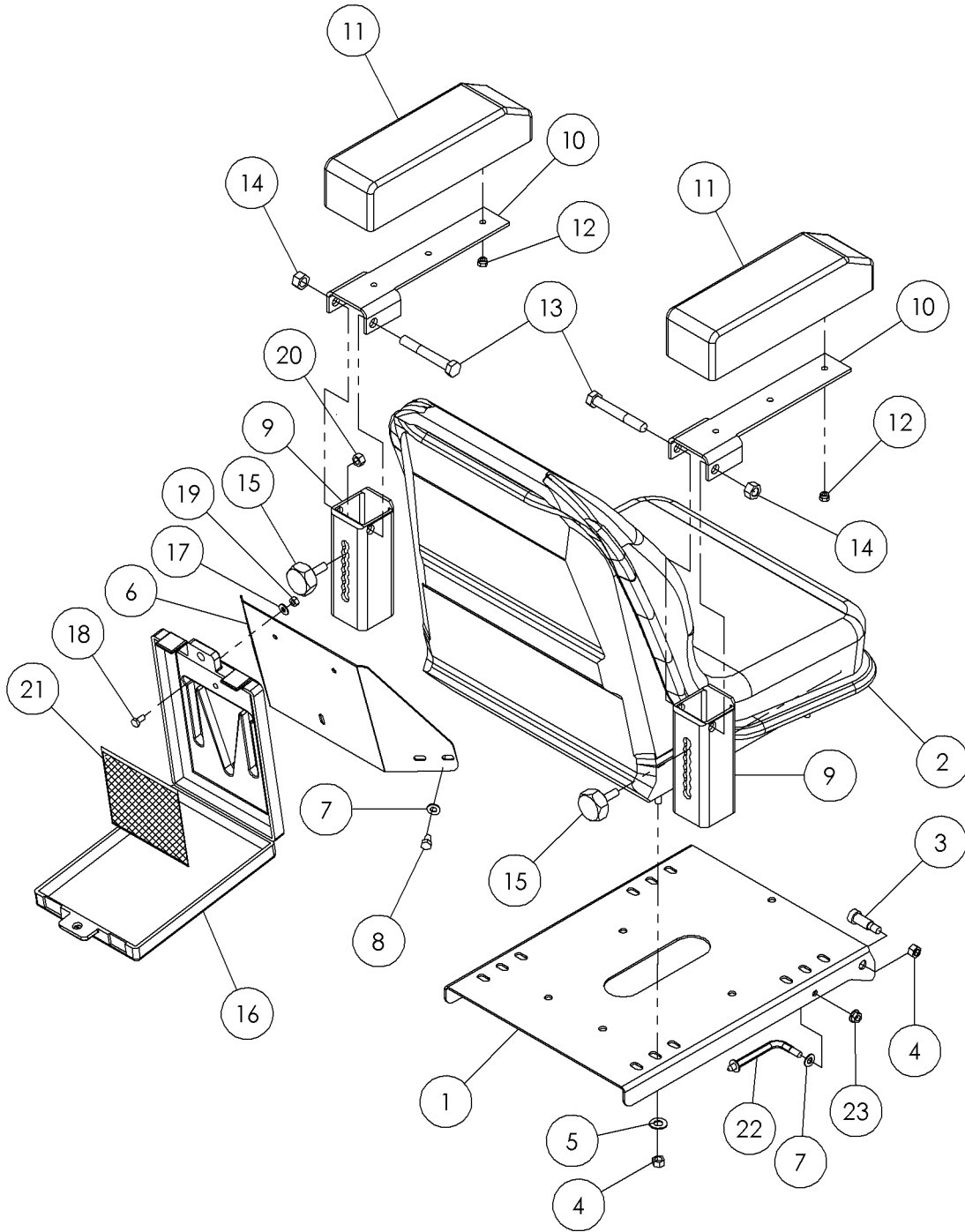

Illustration No. 296280887

## Seat/Arm Rest Fig 3-15

REF. NO.	*	PART NO.	DESCRIPTION	QTY.	REMARKS
1		296307440	PLATE - SEAT MOUNT	1	
2		296274289	SEAT - MILSCO XR210 GRAY	1	
		219186003	SWITCH-SAFETY	1	Not Shown
		4473004	1/4-20X1/2 FLGE WHIZ BOLT	2	Not Shown
3		129671001	SCREW-1/2X1 SOCKET SHOULDER	2	
4		235725001	NUT - HEX - .38 - 16 - GR8 - YZ	6	
5		250515001	7/16 HARD WASHER SAE Y/ZINC	4	
6		235683001	MOUNT-MANUAL BOX	1	
7		235714001	WASHER - FLATSTRL - .31 - .34 X .69 - .06-YZ-A325	5	
8		235740001	BOLT-5/16-18X1/2 GR8 ZYC	4	
9		296274121	ARM - REST SUPPORT UPPER	2	
10		296274122	ARM - REST HINGE PLATE	2	
11		296274120	ARM REST - VINYL	2	
12		103201001	NUT-1/4-20NC NYLON INSERT LOCK	6	
13		238241001	BOLT 1/2"-13X 3 1/2" GR8 HEX	2	
14		75382001	NUT-1/2-UNC GRADE 8 SLTL	2	
15		296274127	HANDLE - SEAT ADJUSTMENT	2	
16		142410001	CASE-6"X9 XCX X1" OPERATOR MANUAL	1	
17		235716001	WASHER - FLATSTRL - .25 -.28 X .63 - .06 - CZ	3	
18		235733001	BOLT-1/4-20X1/2 GR8 ZYC	3	
19		248198001	NUT-1/4 - 20 GR8 TOP LOCK ZINC	3	
20		250508001	NUT - 3/8-NC Gr8 TOP LOCK Y/ZINC	2	
21		2326940	DECAL-NOTICE TO OWNERS	1	Domestic/International
22		296307455	SEAT PROP	1	
23		510352507	NUT - SMFLGTL - .31- 18 - F - YZ	1	

Outrigger Fig 3-16

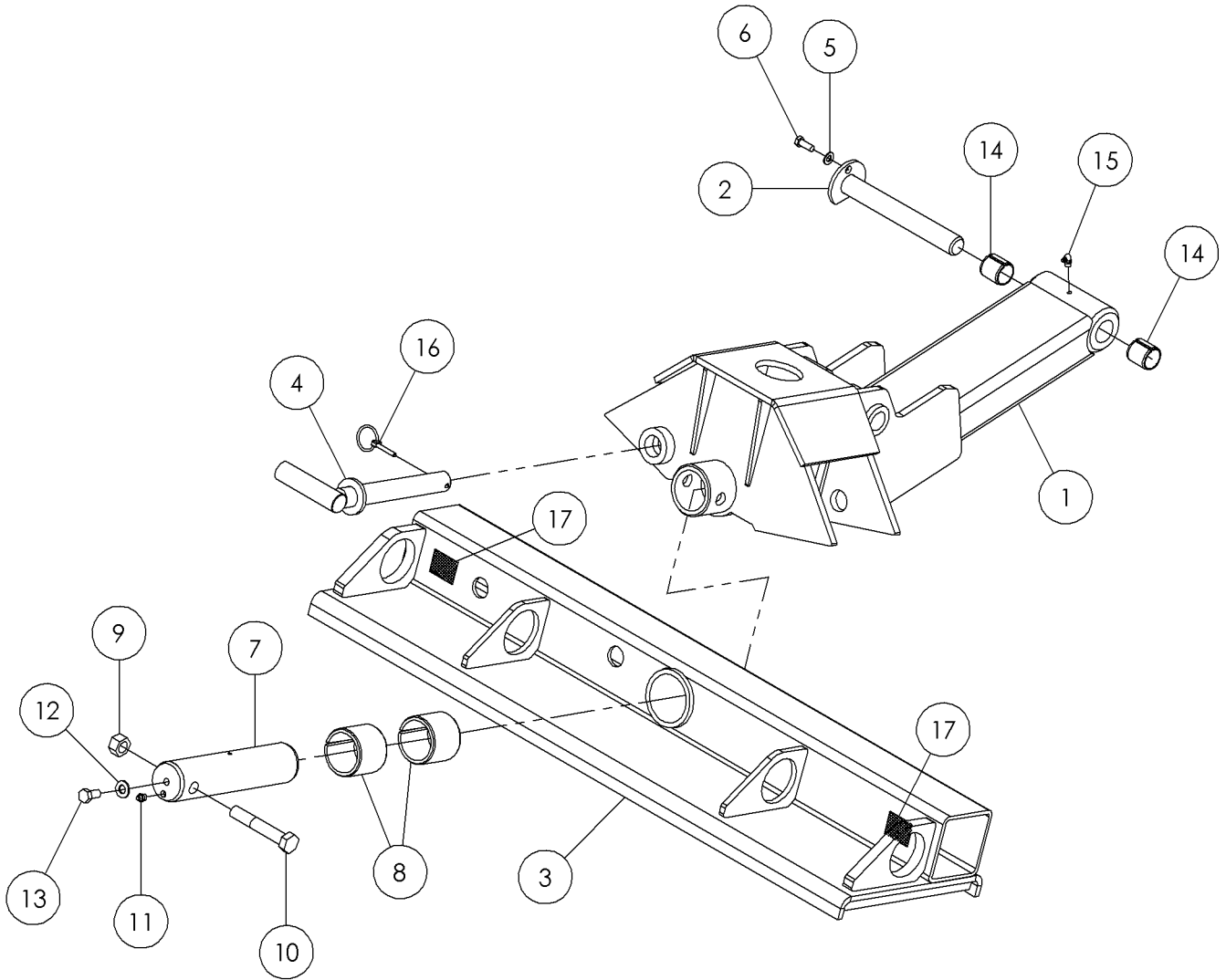

Illustration No. 296279867

## Outrigger Fig 3-16

REF. NO.	*	PART NO.	DESCRIPTION	QTY.	REMARKS
1		296275429	SUB - ARM OUTRIGGER	1	
2		230858001	PIN-OUTRIGGER	1	
3		296275423	PAD - OUTRIGGER	1	
4		296275446	ASSEMBLY - OUTRIGGER PIN	1	
5		235713001	WASHER-FLATSTRL-.38-.41X.81-.06-YA-A325	1	
6		235727001	SCREW-HCS-.38-16X1.00-GR8-YZ	1	
7		235849001	PIN-PIVOT 125@26184	1	
8		1835099	BSHG-STL.3 X 2 1/2-2 1/2	2	
9		250510001	NUT 3/4 NC Gr8 SLTL Y/ZINC	1	
10		235738001	BOLT-HCS-3/4-10X4 1/2 GR8 ZY	1	
11		586001	ZERK-1/8" ST NPT GREASE ZYC	1	
12		485025	WASHER-1/2 FLAT-HARDENED-YZ	1	
13		235729001	SCREW-HCS-.50-13X1.00-GR8-YZ	1	
14		1835027	BSHG.-STL.-1 1/2X1 1/4X1 1/2 REF T05914	2	
15		590001	ZERK-1/8" NPT 90 DEG GREASE	1	
16		1797003	PIN-QUICK LATCH 1/4"- XCX 6M DIA ZYC	1	
17		70001834	DECAL - TIE DOWN POINT	2	

Outrigger Cylinder Fig 3-17

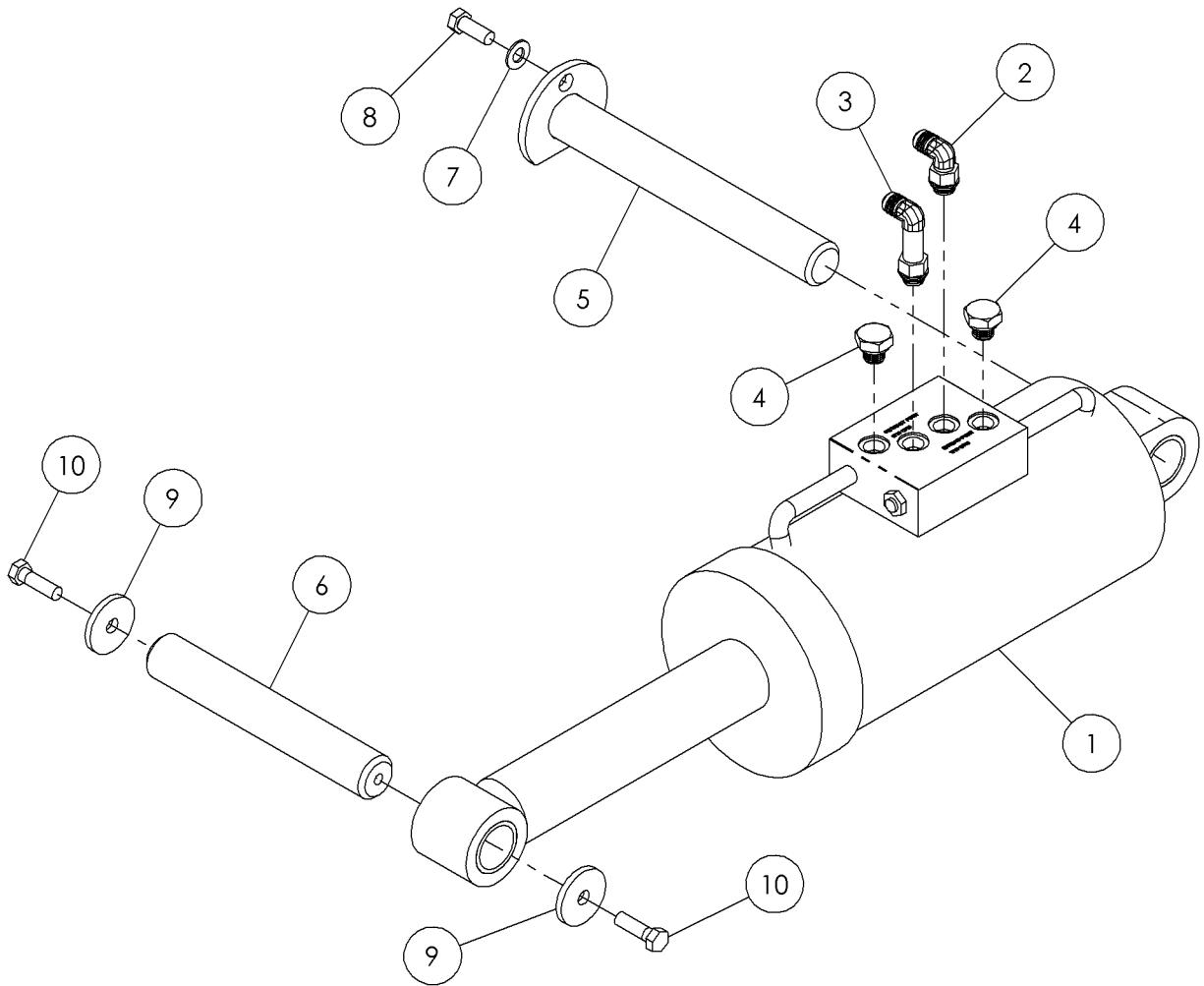
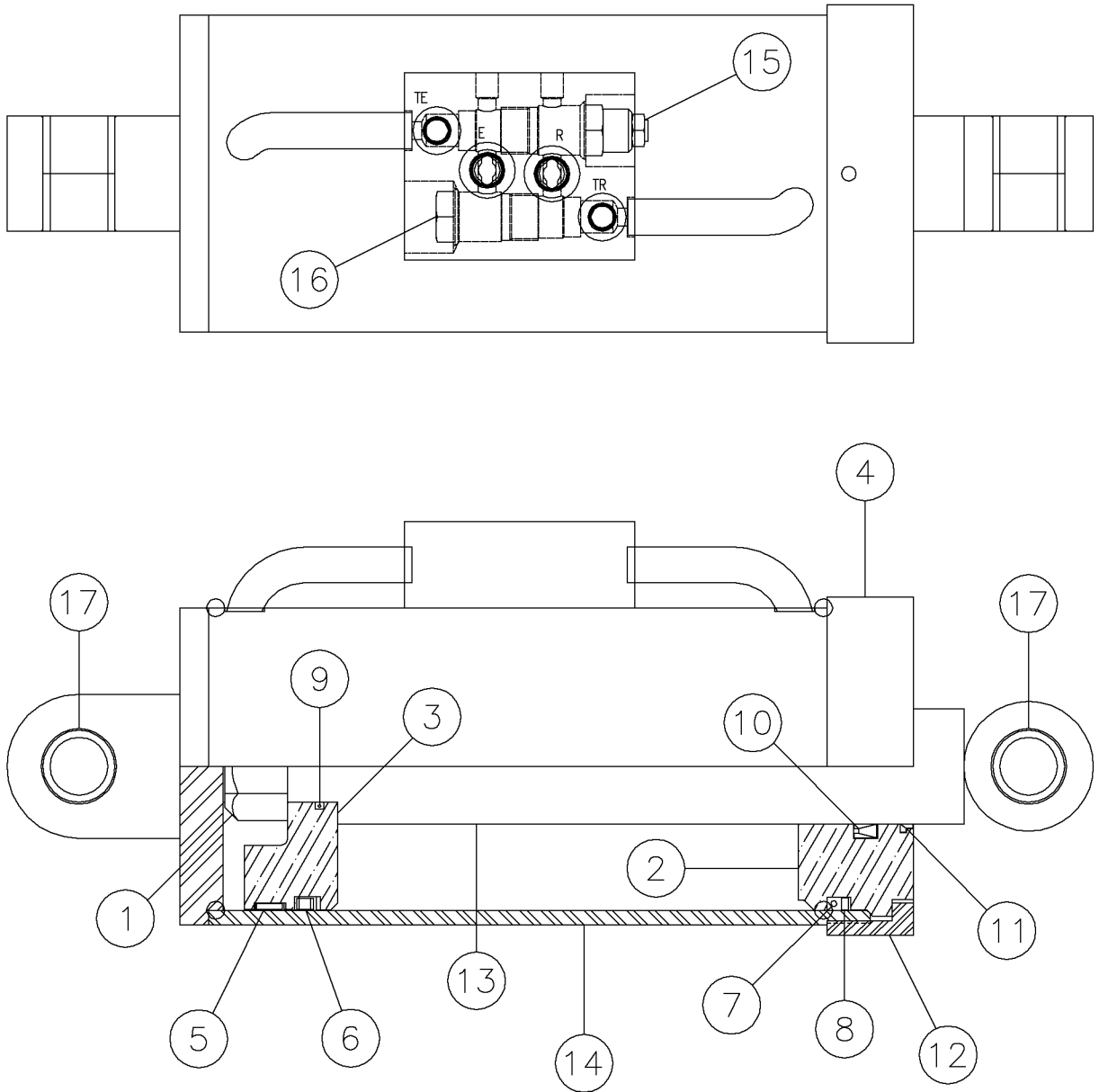

Illustration No. 296279928

## Outrigger Cylinder Fig 3-17

REF. NO.	*	PART NO.	DESCRIPTION	QTY.	REMARKS
1		296280124	CYLINDER - 5 X 8 3000PSI	1	Breakdown Fig. 3-17z01
2		122606001	FITTING-6MX6M JIC90 DEG/ RSTS	1	
3		157172001	FITTING - 6M X 6M JIC LL 90 DEG	1	
4		5553001	FITTING - PLUG - 6MORB - HEX	2	
5		230858001	PIN-OUTRIGGER	1	
6		296292055	PIN - OUTRIGGER	1	
7		235713001	WASHER-FLATSTRL-.38-.41X.81-.06-YA-A325	1	
8		235727001	SCREW-HCS-.38-16X1.00-GR8-YZ	1	
9		277206001	WASHER - FLAT	2	
10		235736001	BOLT-3/8-16X1 1/4 ZYC	2	

Components-Outrigger Cylinder Fig 3-17z01





## Components-Outrigger Cylinder Fig 3-17z01

REF. NO.	*	PART NO.	DESCRIPTION	QTY.	REMARKS
1		296271143	NUT	1	
2		296271144	HEAD	1	
3		296271145	PISTON	1	
4		296271146	NYLOCK SET SCREW	1	
5			WEAR RING	1	Not Sold Separately
6			PSP SEAL	1	Not Sold Separately
7			O-RING	1	Not Sold Separately
8			BACKUP	1	Not Sold Separately
9			O-RING	1	Not Sold Separately
10			ROD SEAL	1	Not Sold Separately
11			DUST SEAL	1	Not Sold Separately
12		296271147	COLLAR - (SET SCREW)	1	
13		296271148	SHAFT W/CLEVIS	1	
14		296271149	BARREL W/PORTS	1	
15		278769023	VALVE	1	
16		278769019	VALVE	1	
17		70070003	BEARING-COMPOSITE 1 LONG	2	
		296280124	CYLINDER - 5 X 8 3000PSI		Inc. All Items In Figure
		296271150	REPAIR KIT		Inc. Ref. 5-11

Outrigger Valve Fig 3-18

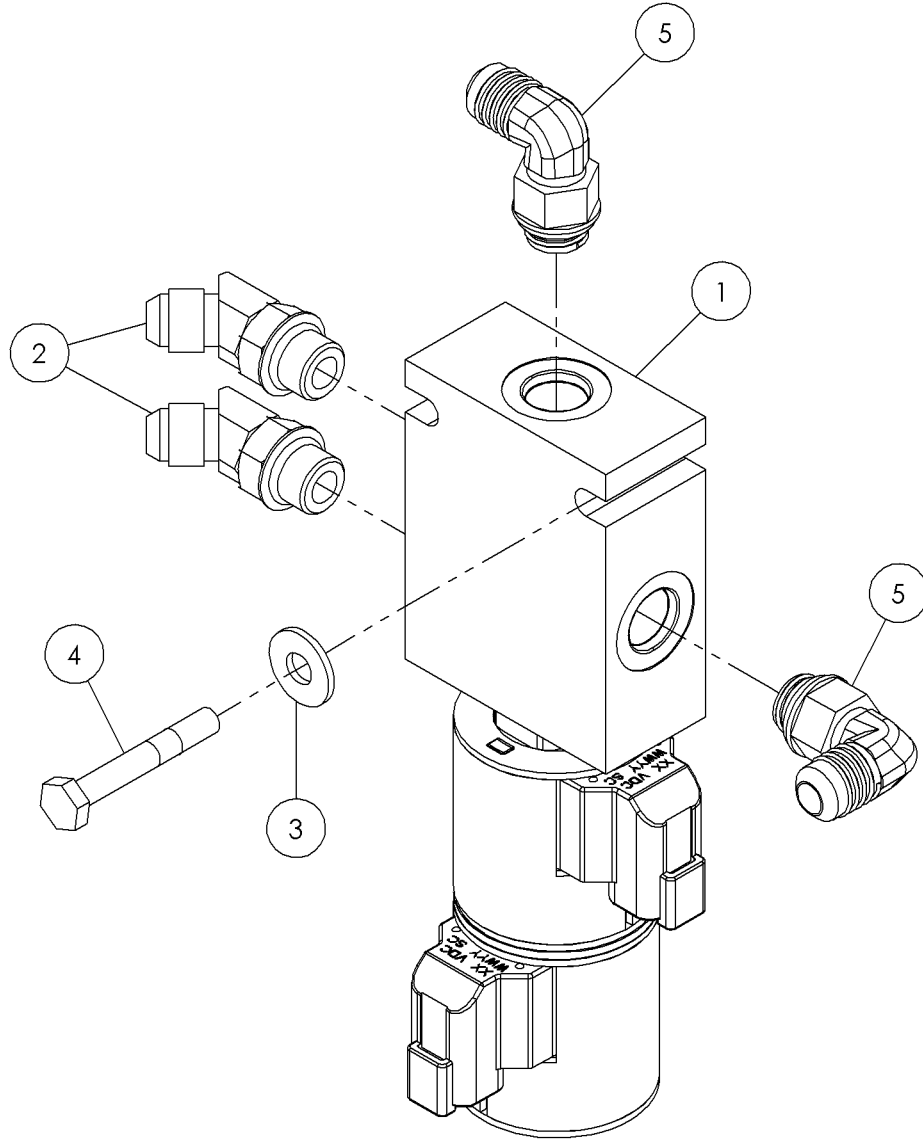
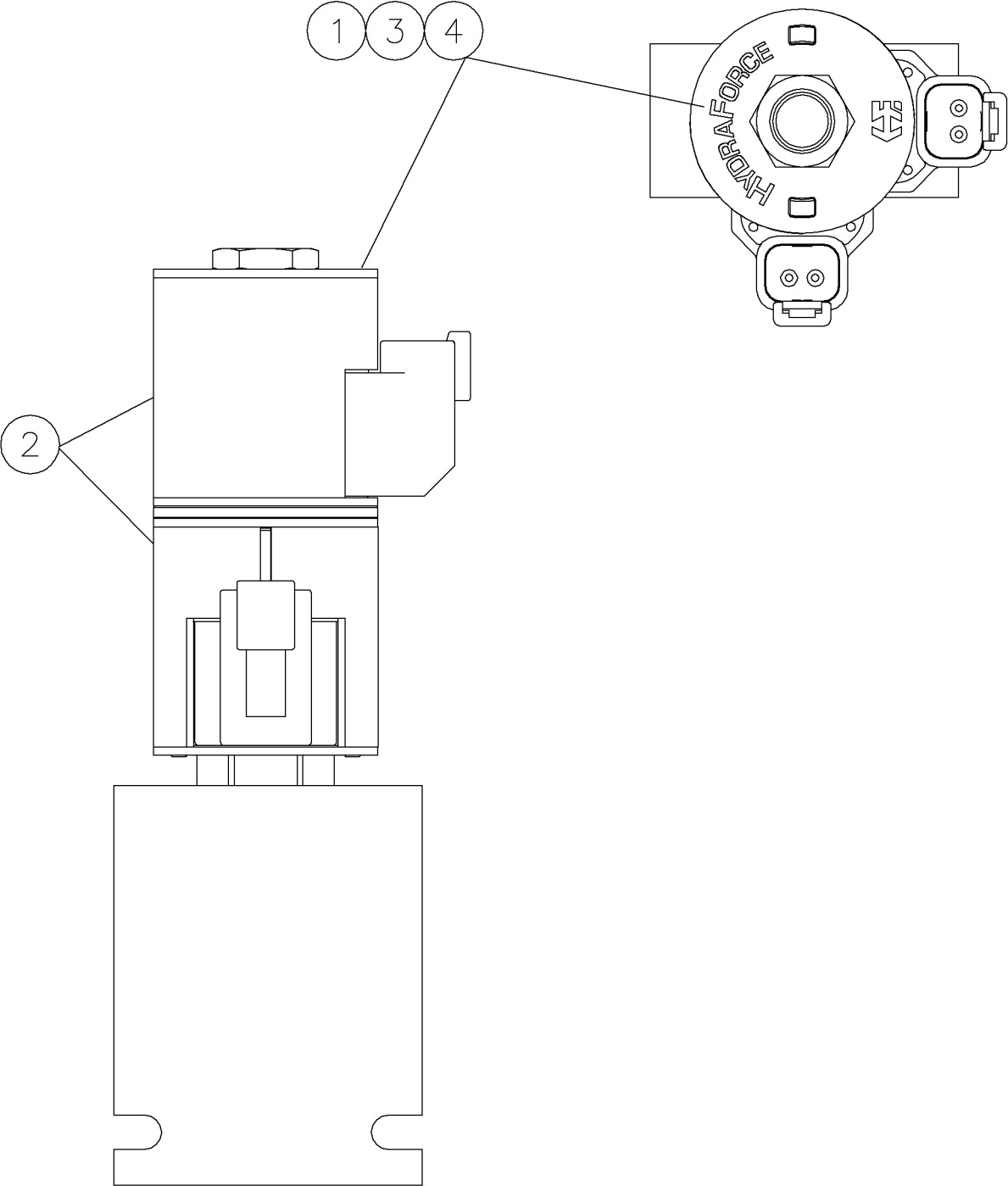

Illustration No. 296279921

## Outrigger Valve Fig 3-18

REF. NO.	*	PART NO.	DESCRIPTION	QTY.	REMARKS
1		296269565	VALVE - 3 POSITION, 4 WAY DUAL SOL.	1	Breakdown Fig. 3-18z01
2		65563001	FITTING - 6M O-RING X 6M JIC 45 DEGREE	2	
3		510337603	WASHER-FLATSTD-.25-.31X.75-.07-YZ	2	
4		248107001	BOLT-1/4-20X1 3/4 GR 8 ZINC PL	2	
5		59426001	FITTING - 90-6MJ-6MORBA	2	

Components-Outrigger Valve Fig 3-18z01



## Components-Outrigger Valve Fig 3-18z01

REF. NO.	*	PART NO.	DESCRIPTION	QTY.	REMARKS
1		251109003	CARTRIDGE - SOLENOID	1	
2		296271077	COILS	2	
3		224886007	NUT	1	
4		296265599	SEAL KIT	1	
		296269565	VALVE - 3 POSITION, 4 WAY DUAL SOL.		Includes All Items In Figure

Umbrella Fig 3-19

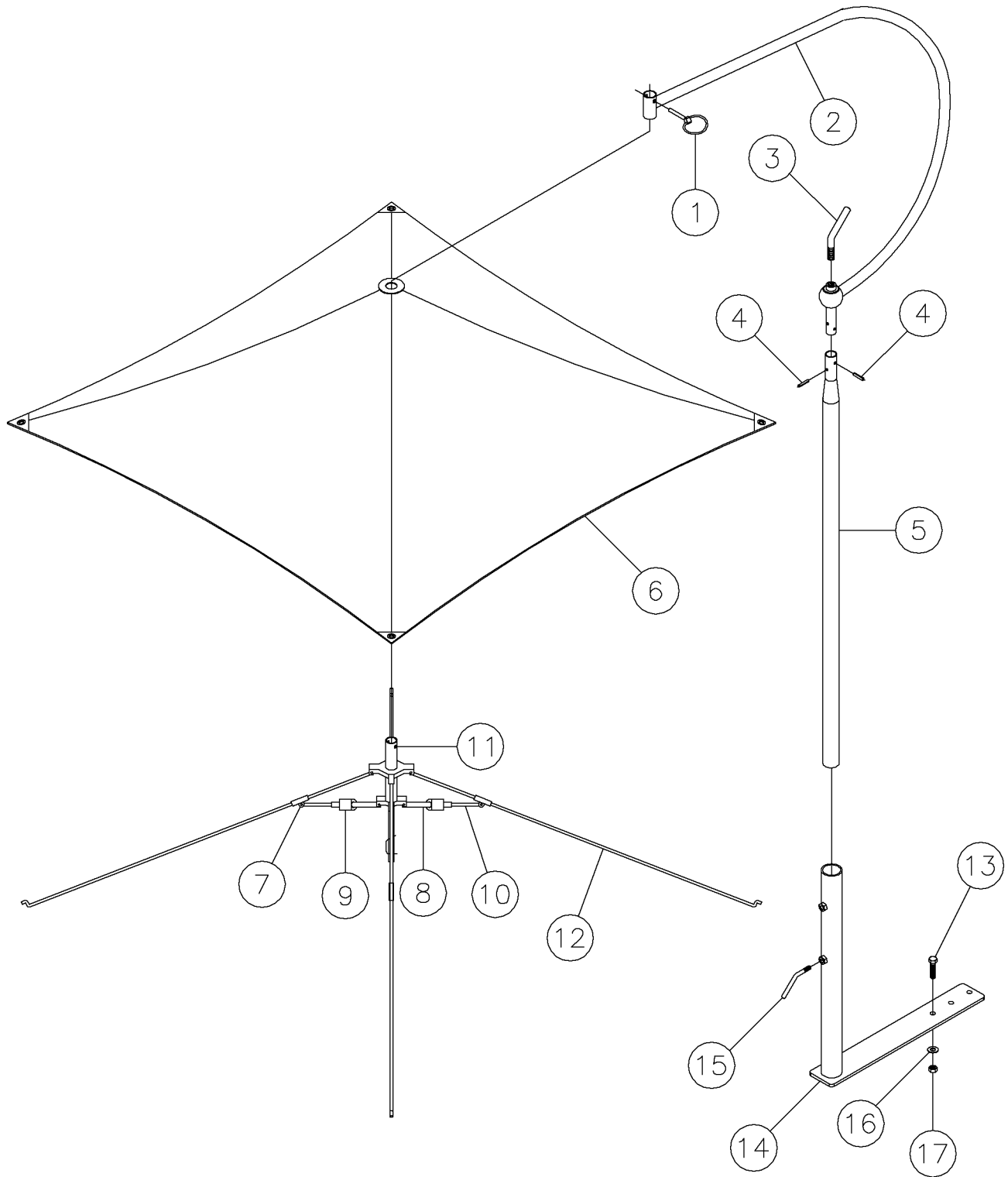

## Umbrella Fig 3-19

REF. NO.	*	PART NO.	DESCRIPTION	QTY.	REMARKS
1		1797003	PIN-QUICK ATTACHMENT LATCH 1/4"-XCX 6M DIA"	1	
2		238181003	CURVED SHAFT	1	
3		238181005	LOCKING HANDLE	1	
4		1978011	PIN ROLL 3/16 X 1 ZINC	2	
5		238181007	SUPPORT SHAFT-UMBRELLA	1	
6		240103001	SHEATH-UMBRELLA	1	
7			RIVET-PUSH PIN	12	Not Sold Separately
8			TUBE-PUSH ROD	4	Not Sold Separately
9			CLIP-PUSH ROD LOCKING SPRING	4	Not Sold Separately
10			PUSH ROD	4	Not Sold Separately
11			CENTER TUBE W/ SPIDERS	1	Not Sold Separately
12			BOW W/ CLEVIS	4	Not Sold Separately
13		235723001	SCREW - HCS -.38 - 16 X 1.50 - GR8 - YZ	3	
14		296280397	WELDMENT-UMBRELLA MOUNT D24X40II	1	
15		240038001	BOLT-TIGHTENING 3/8"	2	
16		235713001	WASHER-FLATSTRL-.38-.41X.81-.06-YA-A325	3	
17		235725001	NUT - HEX - .38 - 16 - GR8 - YZ	3	
		238181001	UMBRELLA-ASSY (PARTS REPAIR)		Inc. Ref. 1-12
		296302417	FRAME-UMBRELLA		Inc. Ref. 7-12
		296302418	FRAME-SUPPORT		Inc. Ref. 8-10

Platform Fig 4-1

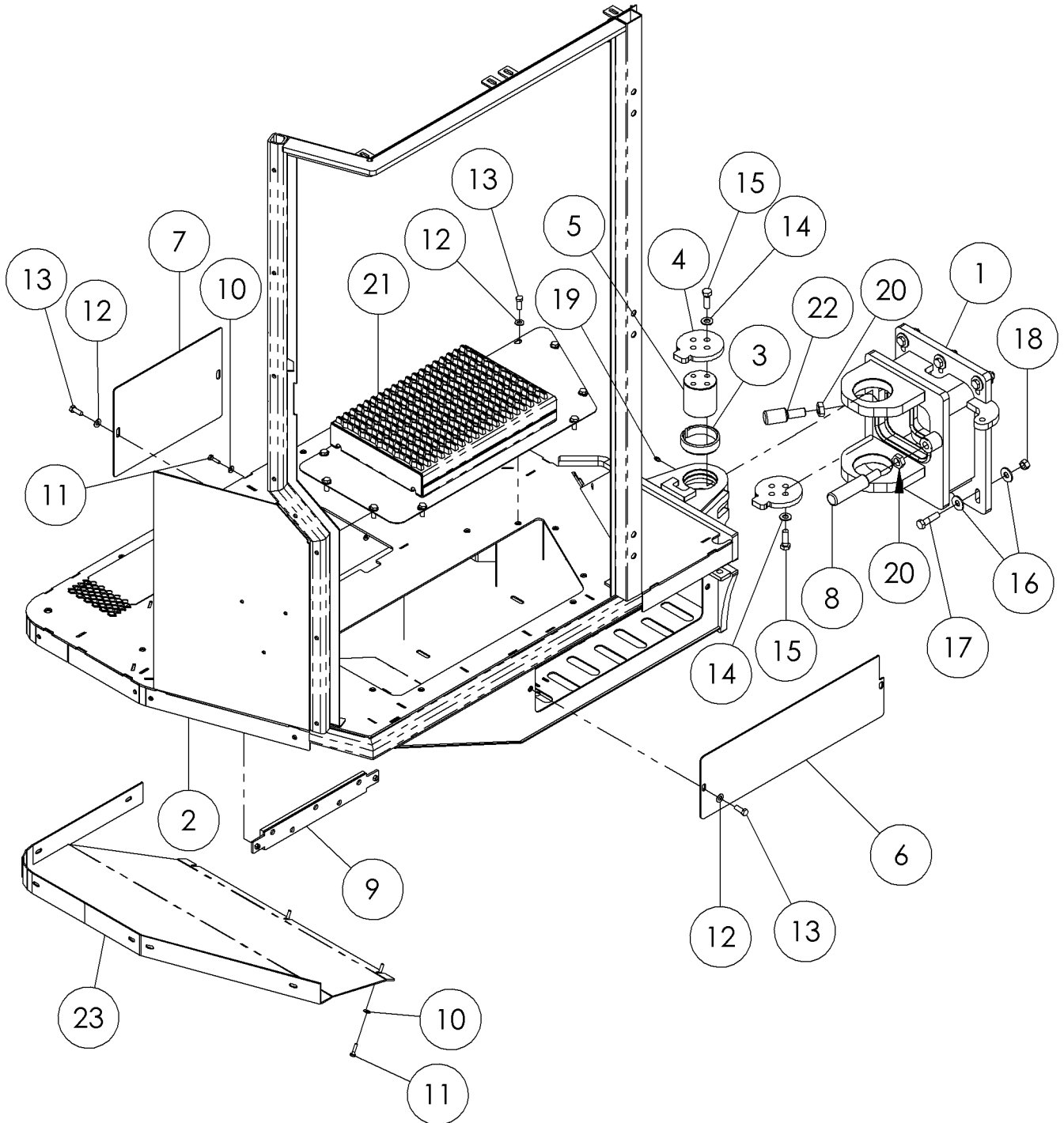

Illustration No. 296284090



Platform Fig 4-1

REF. NO.	*	PART NO.	DESCRIPTION	QTY.	REMARKS
1		296311784	CAB PIVOT - MACHINED JACK BOLT	1	
2		296314284	CAB PLATFORM WELDMENT	1	
3		1835093	BUSHING-STL 3 1/2OD X 3ID -1	2	
4		296286101	PIN RETAINER-MOUNTING OPERATOR PLATFORM	4	
5		296286189	PIN-CAB PIVOT	2	
6		296286208	PLATE-COVER	1	
7		296286209	PLATE-BATTERY COVER	1	
8		296300464	ROD-SWING STOP	1	
9		296300434	COVER-FILLER	1	
10		235716001	WASHER - FLATSTRL - .25 - .28 X .63 - .06 - CZ	6	
11		235735001	BOLT-1/4-20X1 GR8 HEX ZYC	7	
12		235713001	WASHER - FLATSTRL - .38 - .41 X .81 - .06-YA-A325	12	
13		235727001	SCREW-HCS-.38-16X1.00-GR8-YZ	12	
14		485025	WASHER-1/2 FLAT-HARDENED-YZ	16	
15		235721001	BOLT-1/2-13X1 1/2 GR8 ZINC PLT	16	
16		510337611	WASHER - FLATSTD - .50-.56X1.38-.11-YZ	12	
17		235718001	BOLT-1/2-13X2 GR8 HEX ZINC PLT	6	
18		250512001	NUT- 1/2 NC Gr8 TOP LOCK Y/ ZINC	6	
19		598001	FITTING-1/4" NF ST GREASE ZERK	4	
20		433001	NUT-3/4 NC HEX JAM	2	
21		296303306	CAB TREAD	1	
22		296303423	ROD - SWING STOP	1	
23		296308613	SKID - CAB	1	

Control Console Fig 4-2

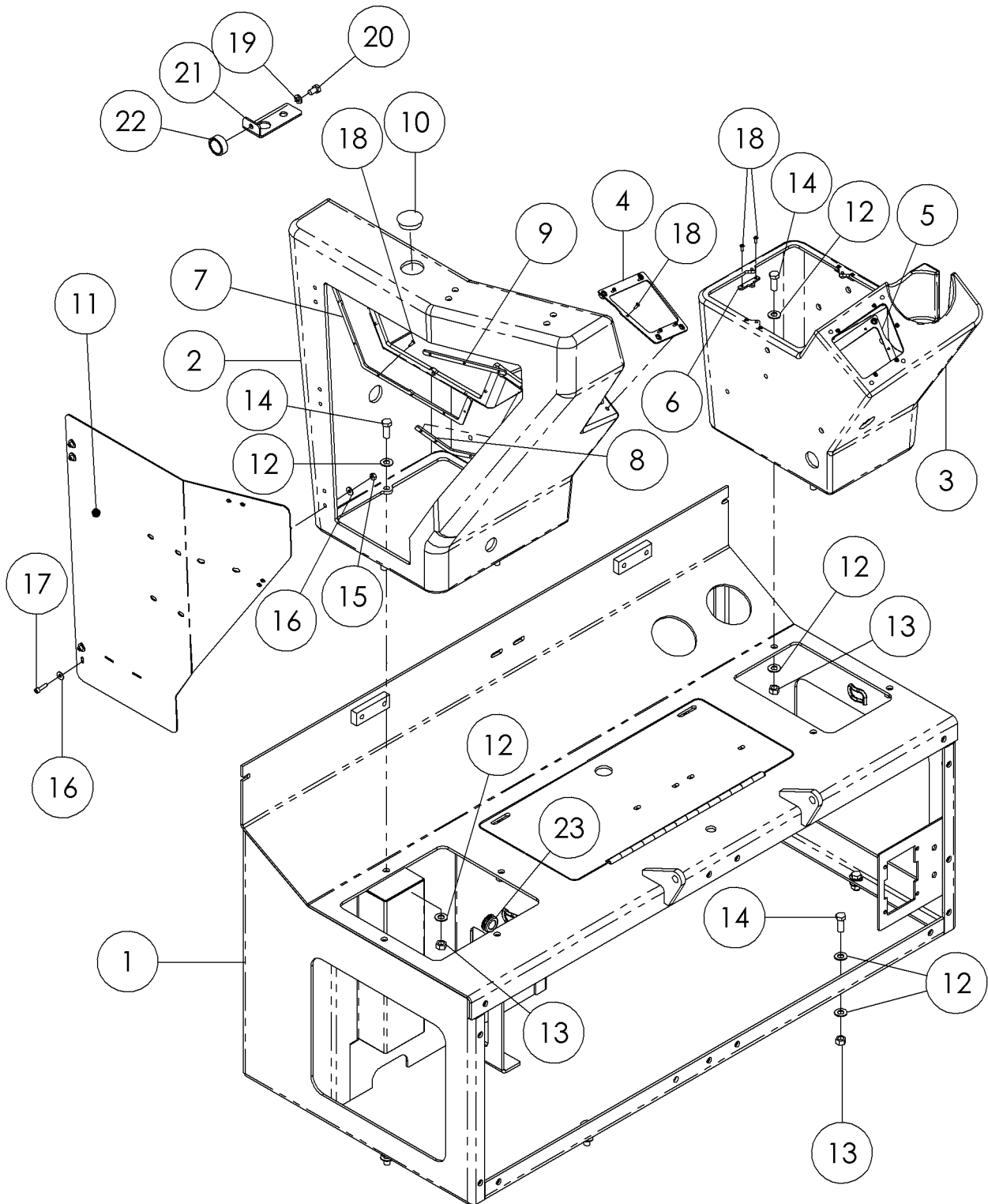
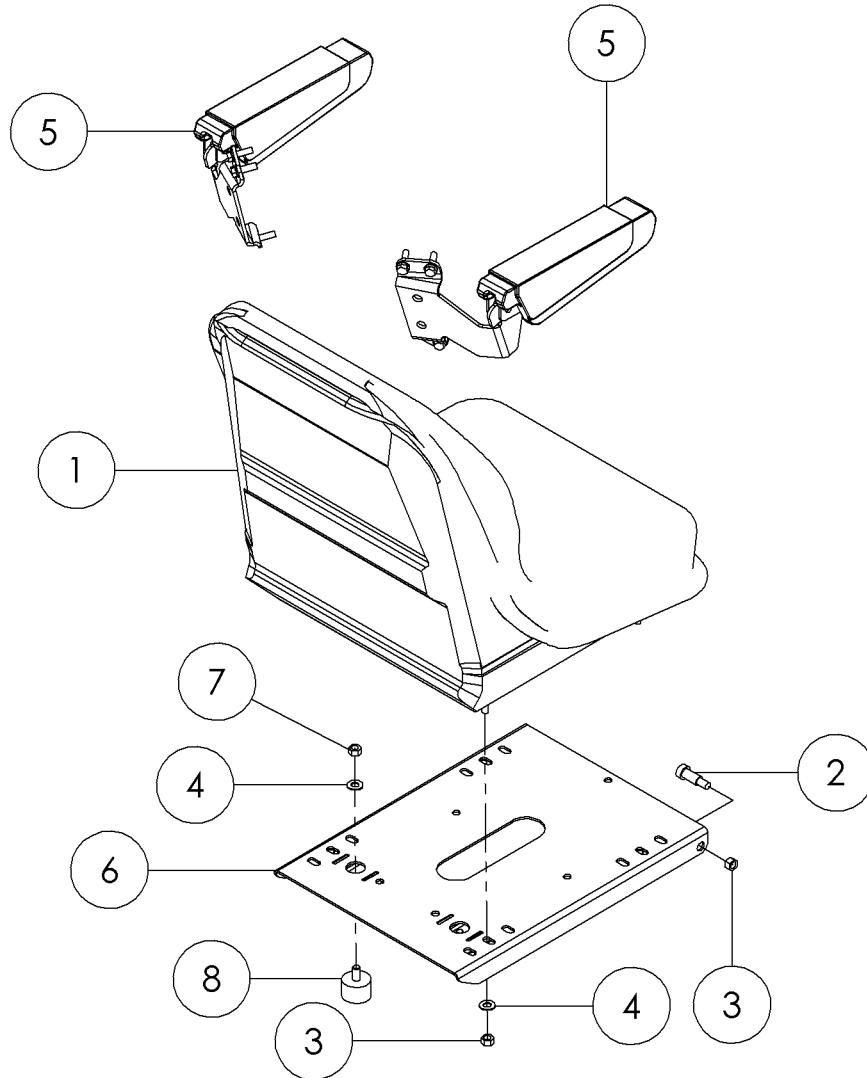

Illustration No. 296284091

## Control Console Fig 4-2

REF. NO.	*	PART NO.	DESCRIPTION	QTY.	REMARKS
1		296300317	WELDMENT-SEAT MOUNT	1	
2		296294068	CONSOLE - OPERATOR RH	1	
3		296294069	CONSOLE - OPERATOR LH	1	
4		296314289	JOYSTICK BEZEL ASSY - RH	1	
5		296314288	JOYSTICK BEZEL ASSY - LH	1	
6		296303484	PLATE - CONTROL PANEL MNT	4	
7		296289239	BEZEL - UPPER RIGHT RH CONSOLE	1	
8		296303485	PLATE - CONTROL PANEL MNT	1	
9		296303486	*PLATE - CONTROL PANEL MNT	1	
10		296294052	PLUG-HOLE 1.50	1	
11		296284185	PLATE - CONSOLE COVER	1	
12		235713001	WASHER - FLATSTRL - .38 - .41 X .81 - .06-YA-A325	24	
13		235725001	NUT - HEX - .38 - 16 - GR8 - YZ	12	
14		235727001	SCREW-HCS-.38-16X1.00-GR8-YZ	12	
15		510312301	NUT-HEX-10-24-GR2-YZ	4	
16		485001	WASHER - FLATSTD - .19 - .22 X .56 - .05 - CZ	8	
17		601298001	SCREW-#10-24X3/4 SOC HD CAP	4	
18		296280370	POP RIVET - ABA46	33	
19		510335705	WASHER-LOCK-.31-.33X.59-.08-YZ	1	
20		235740001	BOLT-5/16-18X1/2 GR8 ZYC	1	
21		296308626	PLATE	1	
22		282642001	MAGNET - 1.25" ROD HOLDER	1	
23		1865015	GROMMET-BLACK/5/8ID-3/16 GR.	1	

Seat Fig 4-3



Seat Fig 4-3

REF. NO.	*	PART NO.	DESCRIPTION	QTY.	REMARKS
1		296274289	SEAT - MILSCO XR210 GRAY	1	
2		129671001	SCREW-1/2X1 SOCKET SHOULDER	2	
3		250508001	NUT - 3/8-NC Gr8 TOP LOCK Y/ZINC	6	
4		235713001	WASHER-FLATSTRL-.38-.41X.81-.06-YA-A325	6	
5		220238001	KIT-MILSCO OLYMPIC ARM REST	1	(Inc. Mounting Bracket & Hardwares)
6		296308546	SEAT - PLATE	1	
7		235725001	NUT - HEX - .38 - 16 - GR8 - YZ	2	
8		122474001	MOUNT-SANDWICH SINGLE STUD	2	

Cab Side-Right Fig 4-4

Illustration No. 296303446

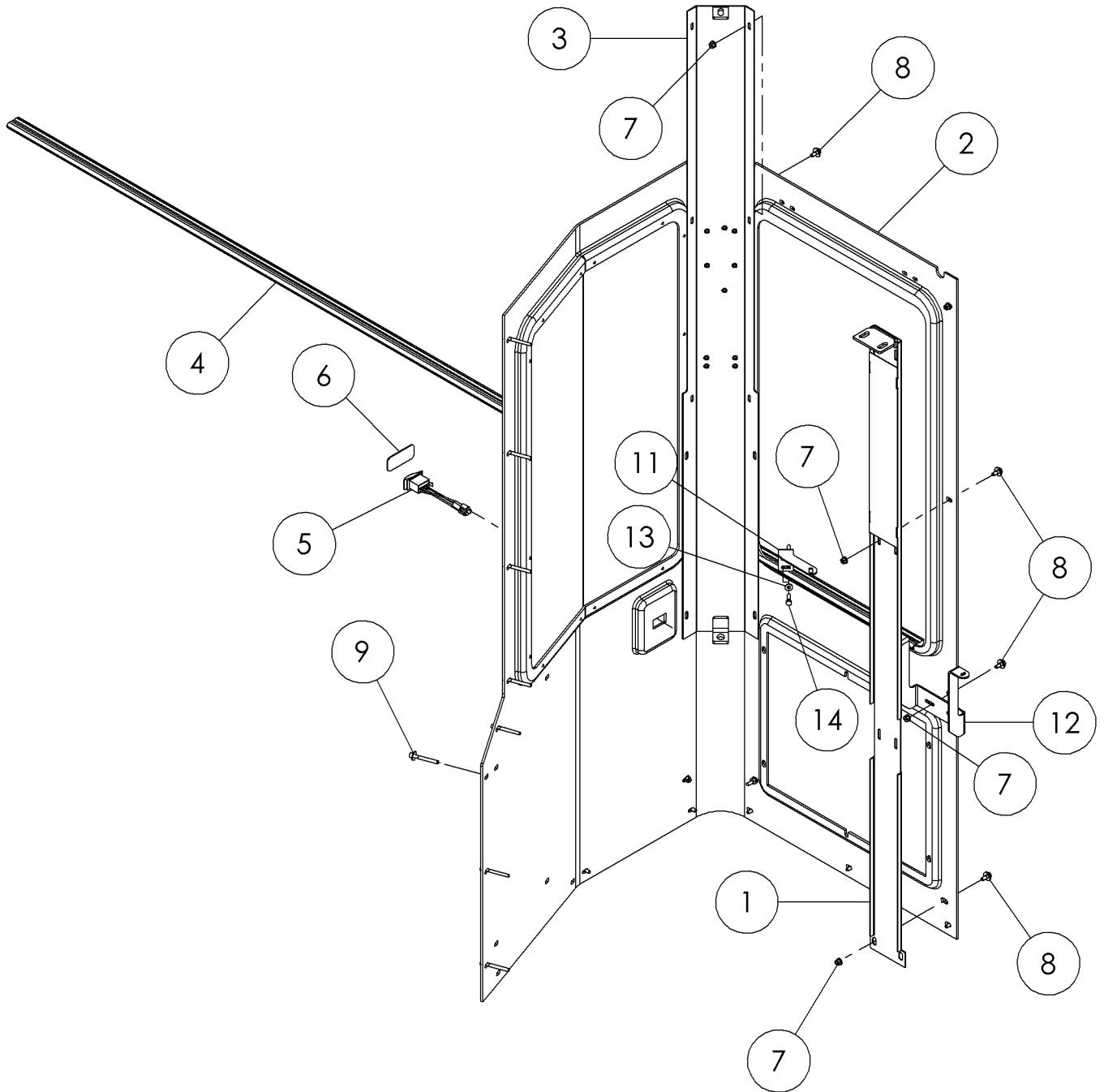

## Cab Side-Right Fig 4-4

REF. NO.	*	PART NO.	DESCRIPTION	QTY.	REMARKS
1		296322032	CAB WALL SUPPORT	1	
2		296310829	CAB WALL ASM - RIGHT	1	Breakdown Fig. 4-4z01
3		296317509	CAB BRACE	1	
4		296303328	PROFILE - CAB WINDOW	1	
5		257541001	SWITCH-SPDT 3 POSITION MOM	1	
6		700ID559	DECAL - CAB SWING	1	Domestic/International
7		296300848	NUT-HEXFLGTL-.25-20-G-YZ	14	
8		296290309	BOLT-SHOULDER 1/4-20UNC X 7/16 W/ 5/16 X 1/4 SHLDR	17	
9		296290311	SCREW - SHCS - .25-20X2.25 W/1/4X3/4 SEAL WSHR-CZ	8	
10		296290310	SCREW - SHCS-.25-20X1.25 W/ 1/4X3/4 SEAL WSHR-CZ	2	
11		296317505	PLATE - WINDOW TRASPORT LATCH	1	
12		296317506	PLATE - WINDOW TRANSPORT LATCH	1	
13		235716001	WASHER - FLATSTRL - .25 -.28 X .63 - .06 - CZ	2	
14		235735001	BOLT-1/4-20X1 GR8 HEX ZYC	2	

Components-Cab Side-Right Fig 4-4z01

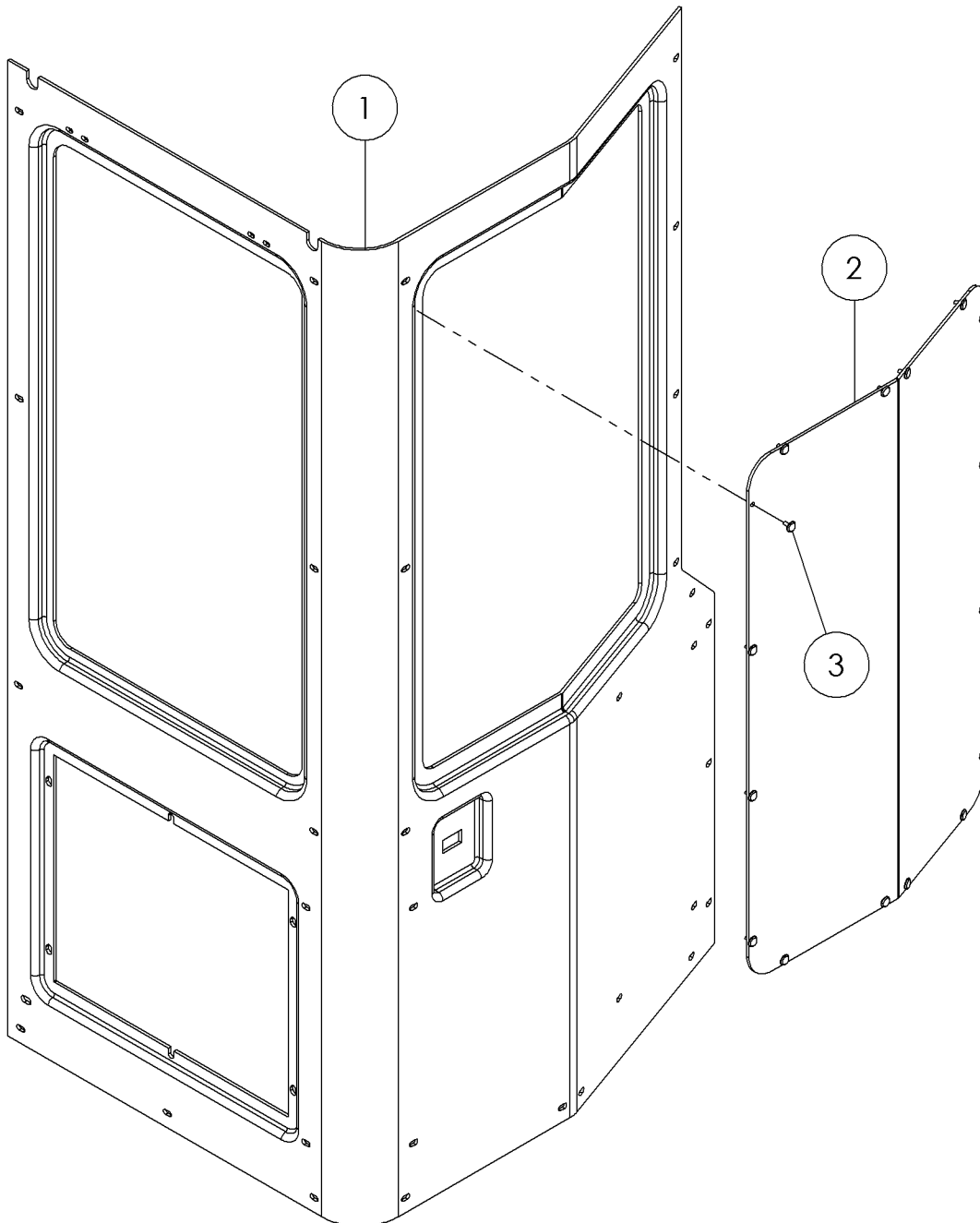

Illustration No. 296303434



## Components-Cab Side-Right Fig 4-4z01

REF. NO.	*	PART NO.	DESCRIPTION	QTY.	REMARKS
1		296300320	SHEET-CAB SIDE	1	
2		296300378	WINDOW - CAB	1	
3		296303371	RIVET - PLASTIC BLIND BLK	16	
		296310829	CAB WALL ASM - RIGHT		Includes All Items In Figure

Cab Side-Left Fig 4-5

Illustration No. 296303447

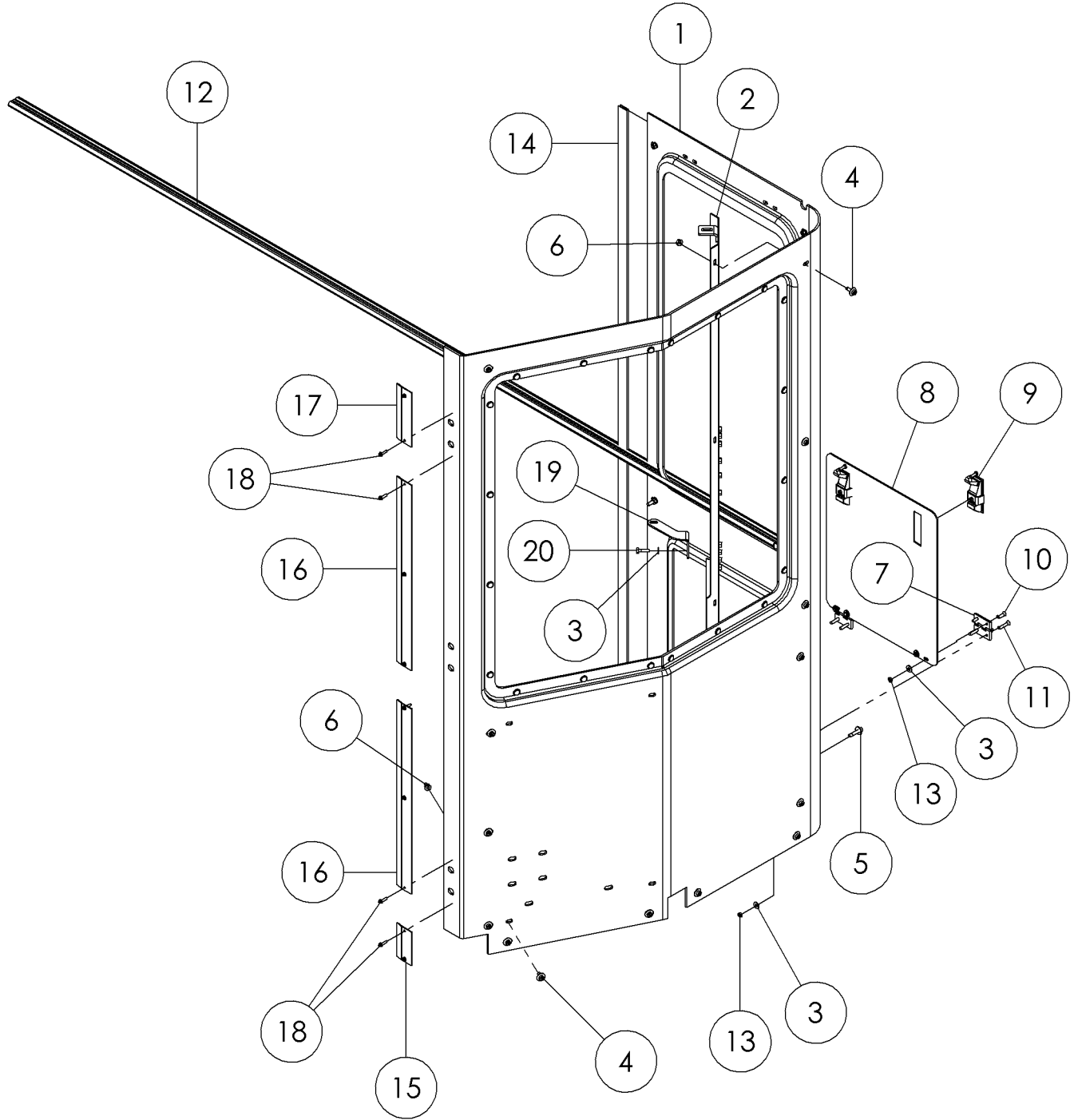

Cab Side-Left Fig 4-5

REF. NO.	*	PART NO.	DESCRIPTION	QTY.	REMARKS
1		296310828	CAB WALL ASSEMBLY - LEFT	1	Breakdown Fig. 4-5z01
2		296317509	CAB BRACE	1	
3		235716001	WASHER-FLATSTRL-.25-.28X.63-.06 - CZ	10	
4		296290309	BOLT-SHOULDER 1/4-20UNC X 7/16 W/ 5/16 X 1/4 SHLDR	22	
5		296290310	SCREW - SHCS-.25-20X1.25 W/ 1/4X3/4 SEAL WSHR-CZ	3	
6		296300848	NUT-HEXFLGTL-.25-20-G-YZ	20	
7		296300276	HINGE - TOOLBOX DOOR	2	
8		296310665	DOOR - ACCESS MED CAB	1	
9		218080001	LATCH-ADJ.LEVER W/RAISED BUTTN(INC KEYS)	2	
9		97874003	KEYS	A/R	(Pair)
10		296284190	SCREW-SFHCS-M6 X 20 ZC 10.9	4	
11		296284189	SCREW-SFHCS-M6 X 30 ZC 10.9	4	
12		296303329	PROFILE - CAB WINDOW	1	
13		296284191	NUT HEX M6 AUTO LOCK NUT	8	
14		296303426	TRIM - H-CHANNEL	1	
15		296308537	CAB DOOR FRAME - ANGLE	1	
16		296308540	CAB DOOR FRAME - ANGLE	2	
17		296308541	CAB DOOR FRAME - ANGLE	1	
18		295229001	SCREW, SELF TAPPING	10	
19		296317502	PLATE - WINDOW TRANSPORT LATCH	1	
20		235735001	BOLT-1/4-20X1 GR8 HEX ZYC	2	

Components-Cab Side-Left Fig 4-5z01

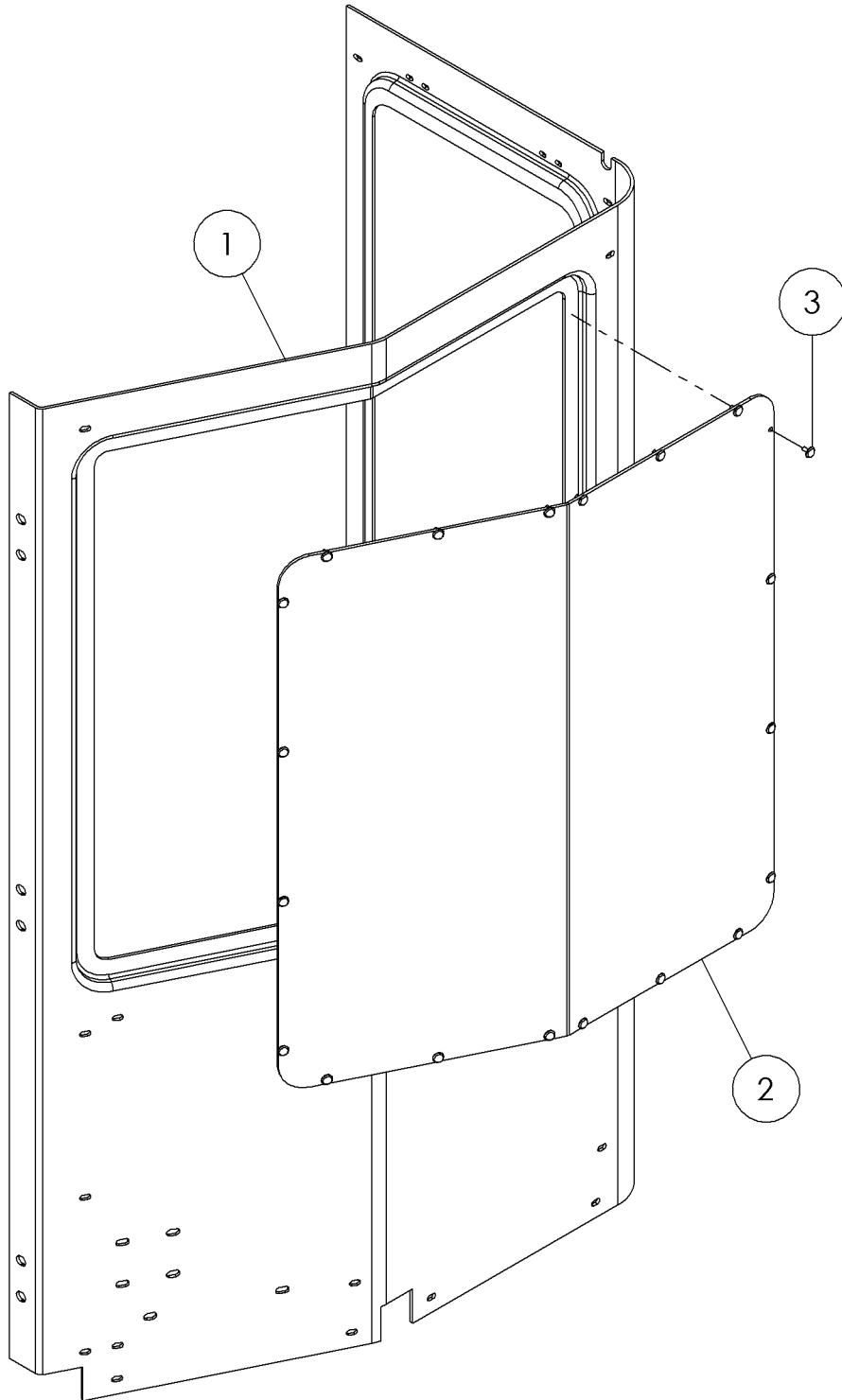

Illustration No. 296303433

## Components-Cab Side-Left Fig 4-5z01

REF. NO.	*	PART NO.	DESCRIPTION	QTY.	REMARKS
1		296300321	SHEET - CAB SIDE	1	
2		296300380	WINDOW - CAB	1	
3		296303371	RIVET - PLASTIC BLIND BLK	20	
		296310828	CAB WALL ASSEMBLY - LEFT		Includes All Items In Figure

Windows Fig 4-6

Illustration No. 296284094

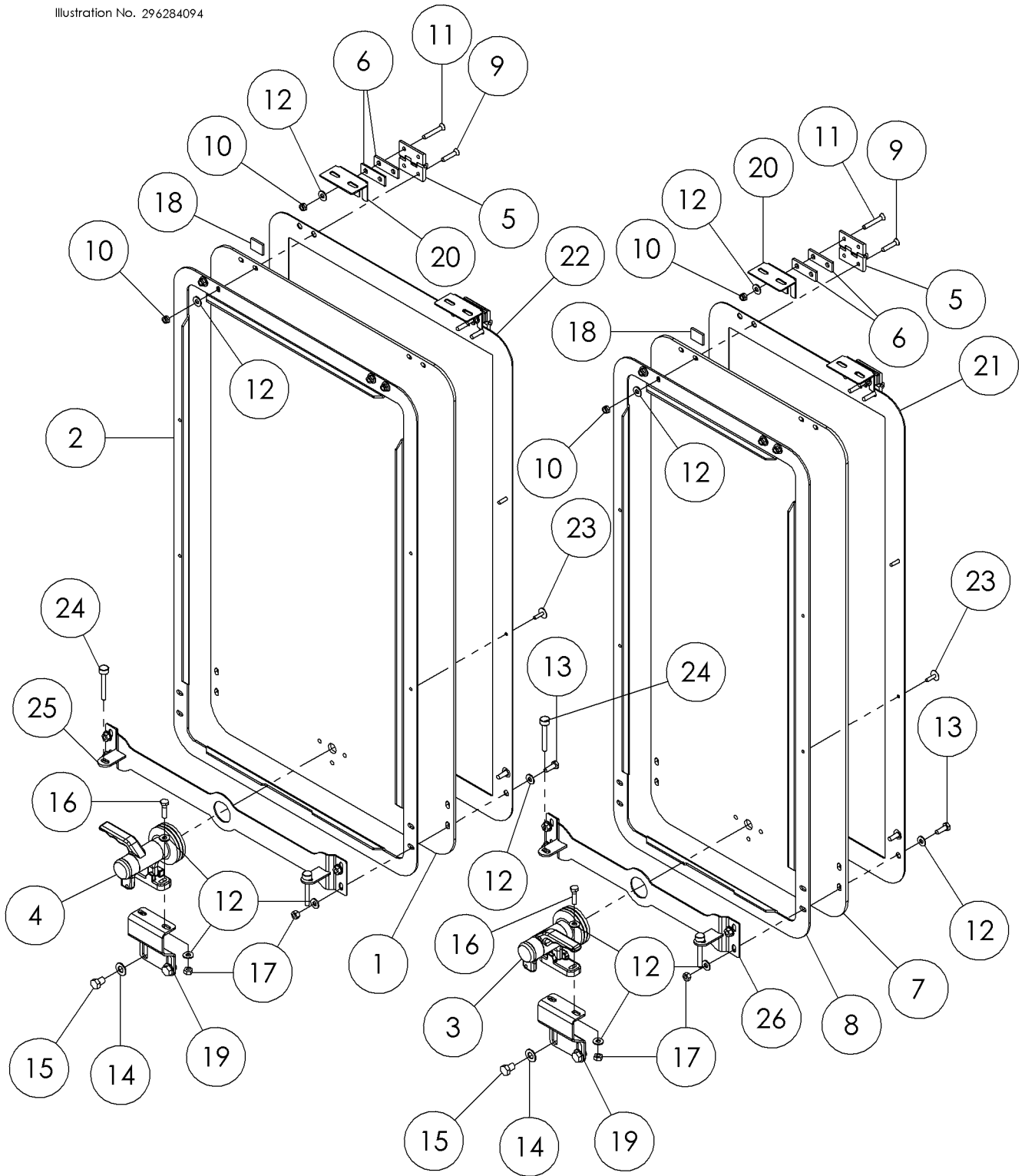

Windows Fig 4-6

REF. NO.	*	PART NO.	DESCRIPTION	QTY.	REMARKS
1		296300377	WINDOW - CAB	1	
2		296303276	PLATE - WINDOW BEZEL	1	
3		296300277	WINDOW STAY - 2 POSITION LH	1	
4		296300278	WINDOW STAY - 2 POSITION RH	1	
5		296300276	HINGE - TOOLBOX DOOR	4	
6		296303300	PLATE - HINGE SPACER	8	
7		296300376	WINDOW - CAB	1	
8		296303302	PLATE - WINDOW BEZEL	1	
9		296284189	SCREW-SFHCS-M6 X 30 ZC 10.9	8	
10		128478001	NUT-HEX NYL M6-1.00 YZ D985	16	
11		296310983	SCREW - SFHCS-M6 1.00 X 40 ZC 10.9	8	
12		235716001	WASHER-FLATSTRL-.25-.28 X .63 - .06 - CZ	40	
13		235734001	BOLT-1/4-20X3/4 GR8 ZYC	8	
14		235713001	WASHER-FLATSTRL-.38-.41X.81-.06-YA-A325	4	
15		240310001	SCREW - HCS - .38 - 16 X .50 - GR8 - YZ	4	
16		235735001	BOLT-1/4-20X1 GR8 HEX ZYC	4	
17		235732001	NUT - HEX - .25 - 20 - GR8 - YZ	12	
18		283148001	ACRYLIC - ADHESIVE TAPE BACK	2	
19		296303421	PLATE - WINDOW STAY MOUNT	2	
20		296308610	PLATE - HINGE SPACER	4	
21		296308628	PLATE - WINDOW	1	
22		296308629	PLATE - WINDOW	1	
23		296310984	RIVET 3/16 X 3/8	8	
24		2108001	LYNCH PIN - 1/4 X 2	4	
25		296317520	WELDMENT - WINDOW STAY	1	
26		296317521	WELDMENT - WINDOW STAY	1	

Door Fig 4-7

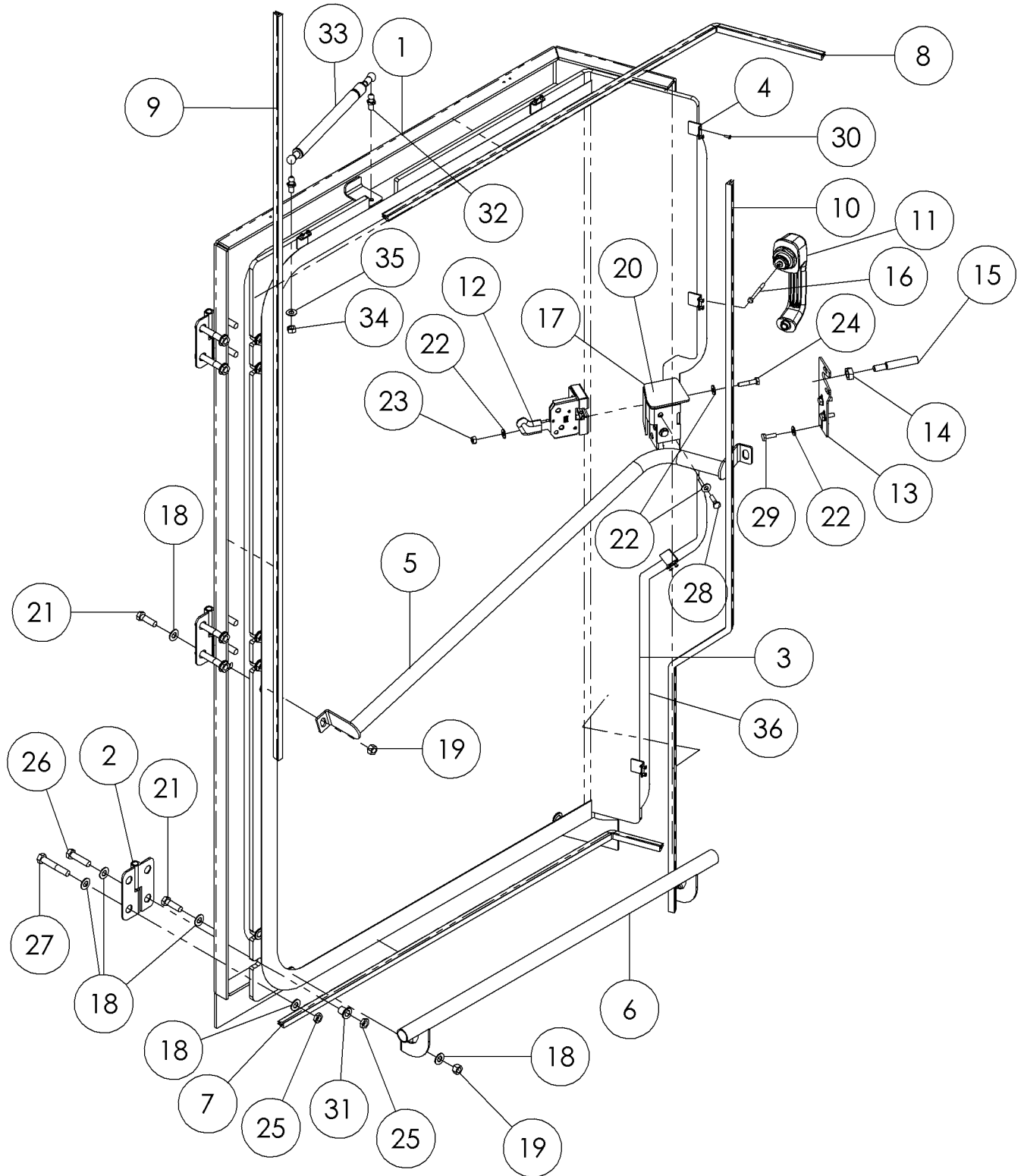

Illustration No. 296284095



## Door Fig 4-7

REF. NO.	*	PART NO.	DESCRIPTION	QTY.	REMARKS
1		296300410	CAB DOOR WELDMENT	1	
2		296300274	HINGE-LIFT OFF LH	3	
3		296300407	SHEET-CAB DOOR	1	
4		296284196	PLATE - WINDOW STOP	6	
5		296300445	WELDMENT-BENT HANDLE	1	
6		296300431	WELDMENT-FOOT RAIL	1	
7		296303330	SEAL - CAB DOOR	1	
8		296303332	PROFILE - CAB WINDOW	1	
9		296303333	PROFILE - CAB WINDOW	1	
10		296303331	PROFILE - CAB WINDOW	1	
11		296300271	HANDLE-PUSH BUTTON D250	1	
12		296284117	DOOR LATCH-ANTI BURST	1	
13		296314283	PLATE - DOOR LATCH MOUNT	1	
14		75383001	NUT-1/2-UNC GR.8 JAM HEX	1	
15		296314282	CAB - DOOR STRIKER	1	
16		506030050	SCREW-HCS,M5-.80X50,8.8,YZ,D931,PT	1	
17		296308542	LATCH COVER	1	
18		235713001	WASHER-FLATSTRL-.38-.41X.81-.06-YA-A325	25	
19		250508001	NUT - 3/8-NC Gr8 TOP LOCK Y/ZINC	4	
20		235726001	BOLT-3/8-16X3/4 GR8 HEX ZNCPLT	1	
21		510308114	BOLT-CARG-.38-16X1.50-GR5-YZ	1	
22		235736001	BOLT-3/8-16X1 1/4 ZYC	2	
23		235716001	WASHER-FLATSTRL-.25-.28X.63-.06 - CZ	9	
24		235732001	NUT - HEX - .25 - 20 - GR8 - YZ	2	
25		250008001	BOLT 1/4-20 X 1 1/4 ZINC PL	2	
26		507090010	NUT-HEX,M10-1.50,CL10,YZ,ISO4032	12	
27		507092025	*SCREW-HCS,M10-1.50X25,8.8,YZ,ISO4017,FT	6	
28		507092060	SCREW-HCS,M10-1.50X60,8.8,YZ,ISO4014,PT	6	
29		235735001	BOLT-1/4-20X1 GR8 HEX ZYC	2	
30		235734001	BOLT-1/4-20X3/4 GR8 ZYC	3	
31		296280370	POP RIVET - ABA46	12	
32		296317519	SPACER - CAB DOOR	9	
33		296300280	STUD - GAS SPRING	2	
34		296300279	GAS SPRING - CAB DOOR	1	
35		240333001	NUT-5/16-18 GR8 TL ZINC PLTD	2	
36		235714001	WASHER-FLATSTRL-.31-.34X.69-.06-YZ-A325	2	
37		296318057	URETHANE - WINDOW WELD	1	

Control Panel/Upper RH W/Cab Fig 4-8

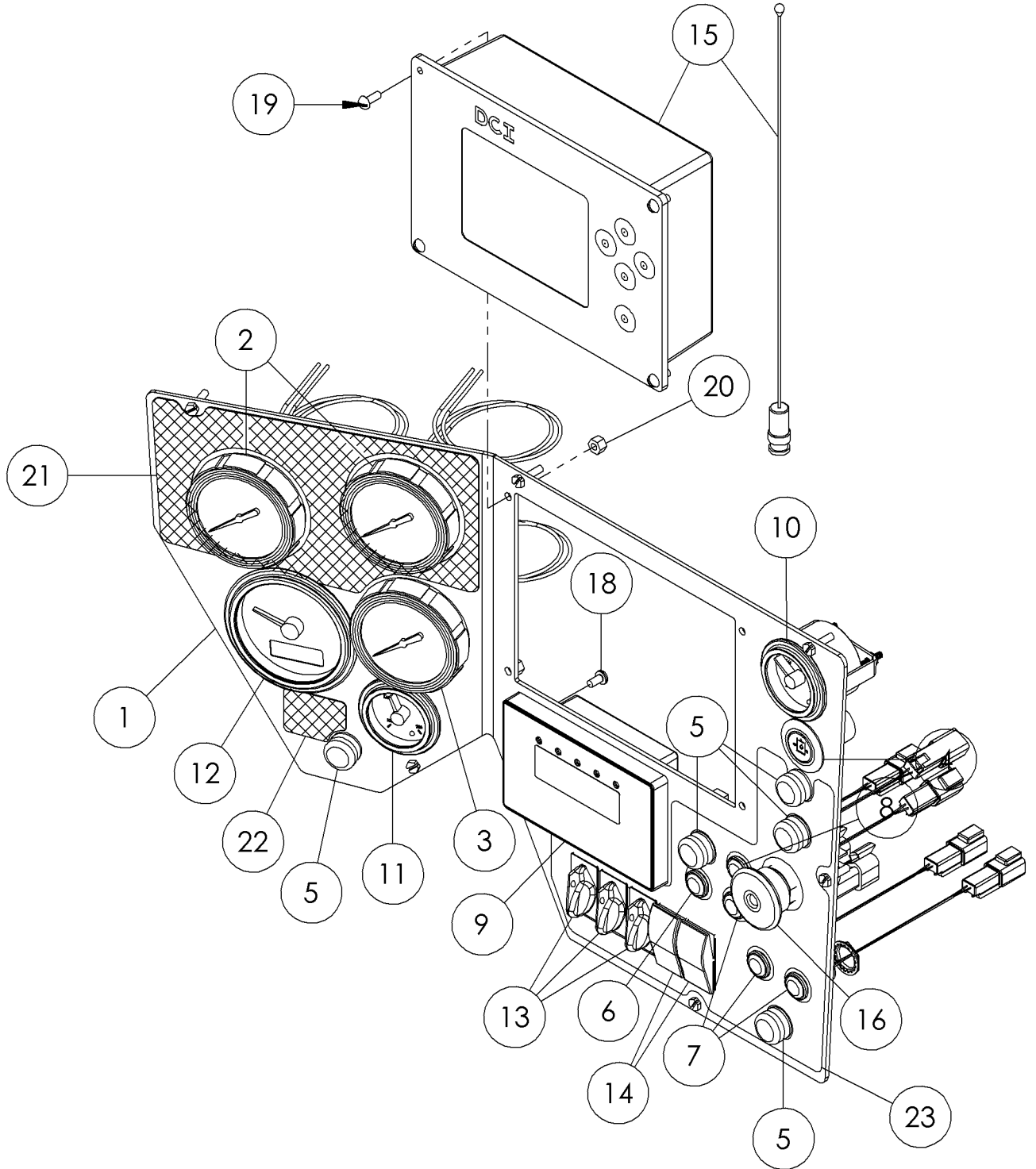

Illustration No. 296303346

## Control Panel/Upper RH W/Cab Fig 4-8

REF. NO.	*	PART NO.	DESCRIPTION	QTY.	REMARKS
1		296307778	PLATE - RH CONSOLE FACE	1	
2		289651001	GAUGE - 7500 PSI - SPAN - JIC - LIGHT	2	
3		289650001	GAUGE - 2000 PSI - SPAN - JIC - LIGHT	1	
4		277699001	SWITCH - PUSH BUTTON HYDRAULIC ENABLE	1	
5		260766001	SWITCH-MOM BUTTON NO	5	
6		296275581	LIGHT - REMOTE LOCKOUT-GREEN	1	
7		296275582	LIGHT - REMOTE LOCKOUT- RED	3	
8		296275583	LIGHT - REMOTE LOCKOUT - AMBER	1	
9		296287271	ASM - LED MID SIZE HDD	1	
10		296274330	GAUGE - FUEL	1	
11		296274329	GAUGE-TEMP DATCON 12V W/ DEUTSCH CONNECTR	1	
12		163627173	TACHOMETER CANBUS	1	
13		296286254	ROTARY SWITCH (ON) - OFF - (ON)	3	
14		257205001	SWITCH-SP 2 POSITION	2	
15		296281928	MFD /W ANTENNA 13" BNC	1	
16		296259684	BUTTON - RED PUSH/PULL	1	
17		510357010	SCREW-MCH-10-24X.75-GR2-YZ-HWH- SLOTTED	6	
18		229830001	SCREW-TFTAP-M5X10-YZ-D7500	4	
19		533004	BOLT-10-24X1/2 RND.HD.SLTMACH	4	
20		284471001	NUT - 10-24	4	
21		700ID542	DECAL - LH CONTROL PANEL	1	
22		700ID540	DECAL - CONTROL PANEL W/ CAB	1	
23		700ID569	DECAL - CONTROL PANEL W/CAB	1	

Control Panel-LH Fig 4-9

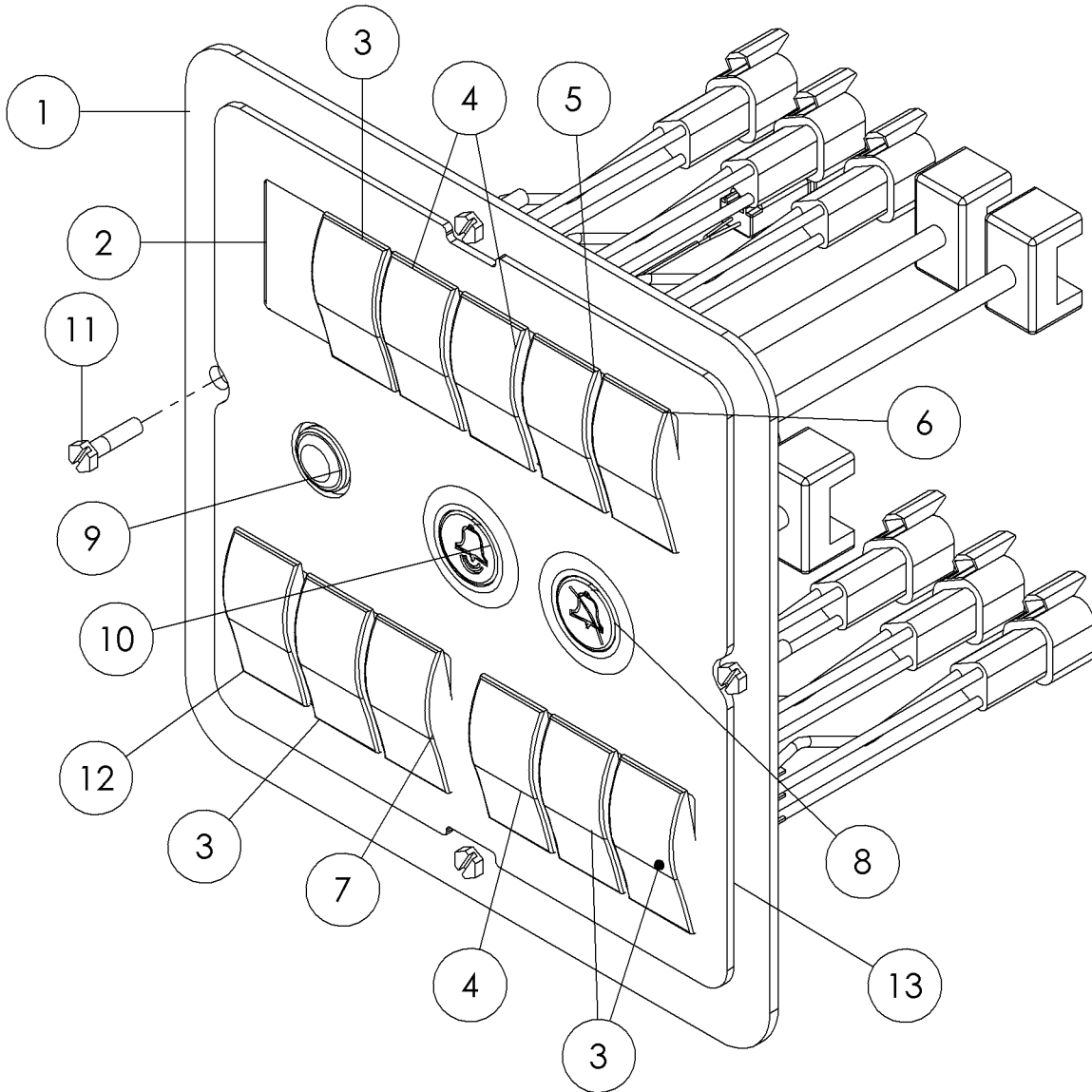

Illustration No. 296284097

## Control Panel-LH Fig 4-9

REF. NO.	*	PART NO.	DESCRIPTION	QTY.	REMARKS
1		296300530	PLATE-LH CONSOLE DOOR	1	
2		156720001	PLUG - ROCKER SWITCH	1	
3		257541001	SWITCH-SPDT 3 POSITION MOM	4	
4		257205001	SWITCH-SP 2 POSITION	3	
5		296269576	SWITCH - ON/ON/ON	1	
6		296274146	SWITCH - SP 3 POSITION	1	
7		296276112	SWITCH-CARLING CONTURA II ON/ON/ ON 24V	1	
8		296280268	SWITCH-PUSH BUTTON STRK ALERT ALARM OFF	1	
9		296275581	LIGHT - REMOTE LOCKOUT-GREEN	1	
10		296280273	SWITCH - PUSH BUTTON STRIKE ALERT TEST	1	
11		510357010	SCREW-MCH-10-24X.75-GR2-YZ-HWH- SLOTTED	4	
12		296276068	SWITCH-CARLING CONTURA II ON/OFF/ ON	1	
13		700ID543	DECAL - LH CONTROL PANEL	1	

Joystick Panel-LH Fig 4-10

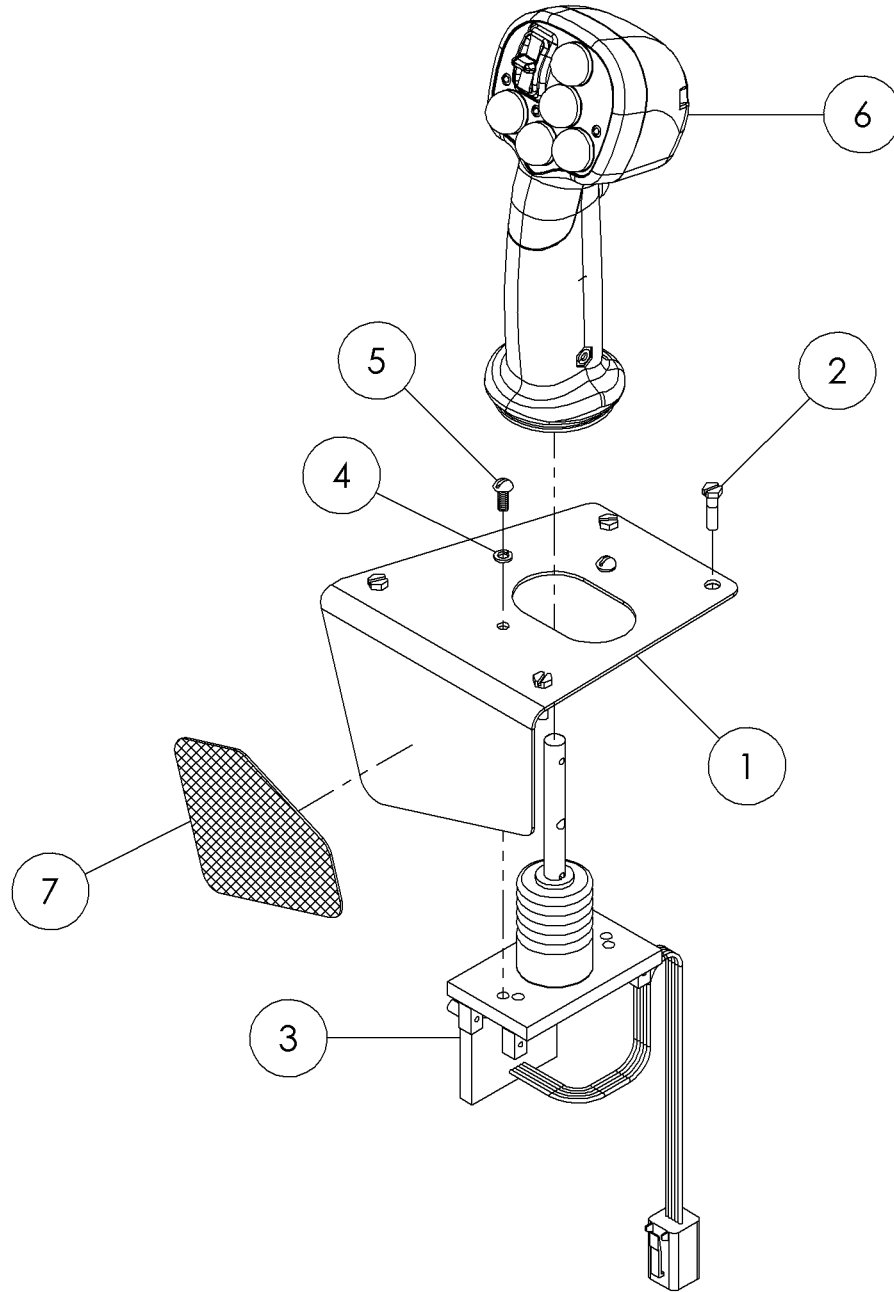

Illustration No. 296284098

## Joystick Panel-LH Fig 4-10

REF. NO.	*	PART NO.	DESCRIPTION	QTY.	REMARKS
1		296284110	PLATE-JOYSTICK MOUNT LH	1	
2		510357010	SCREW-MCH-10-24X.75-GR2-YZ-HWH-SLOTTED	4	
3		296282533	JOYSTICK - SPRING CENTERED	1	
4		480001	WASHER-3/16 S/T LOC	2	
5		1802004	BOLT-3/16"NF X 1/2" STOVE	2	
6		296273907	HANDLE GRIP ASSEMBLY - LEFT JOYSTICK	1	Breakdown Fig. 4-10z01
7		700IC857	DECAL-LEFT JOYSTICK CONTROL	1	

Components-Joystick Fig 4-10z01

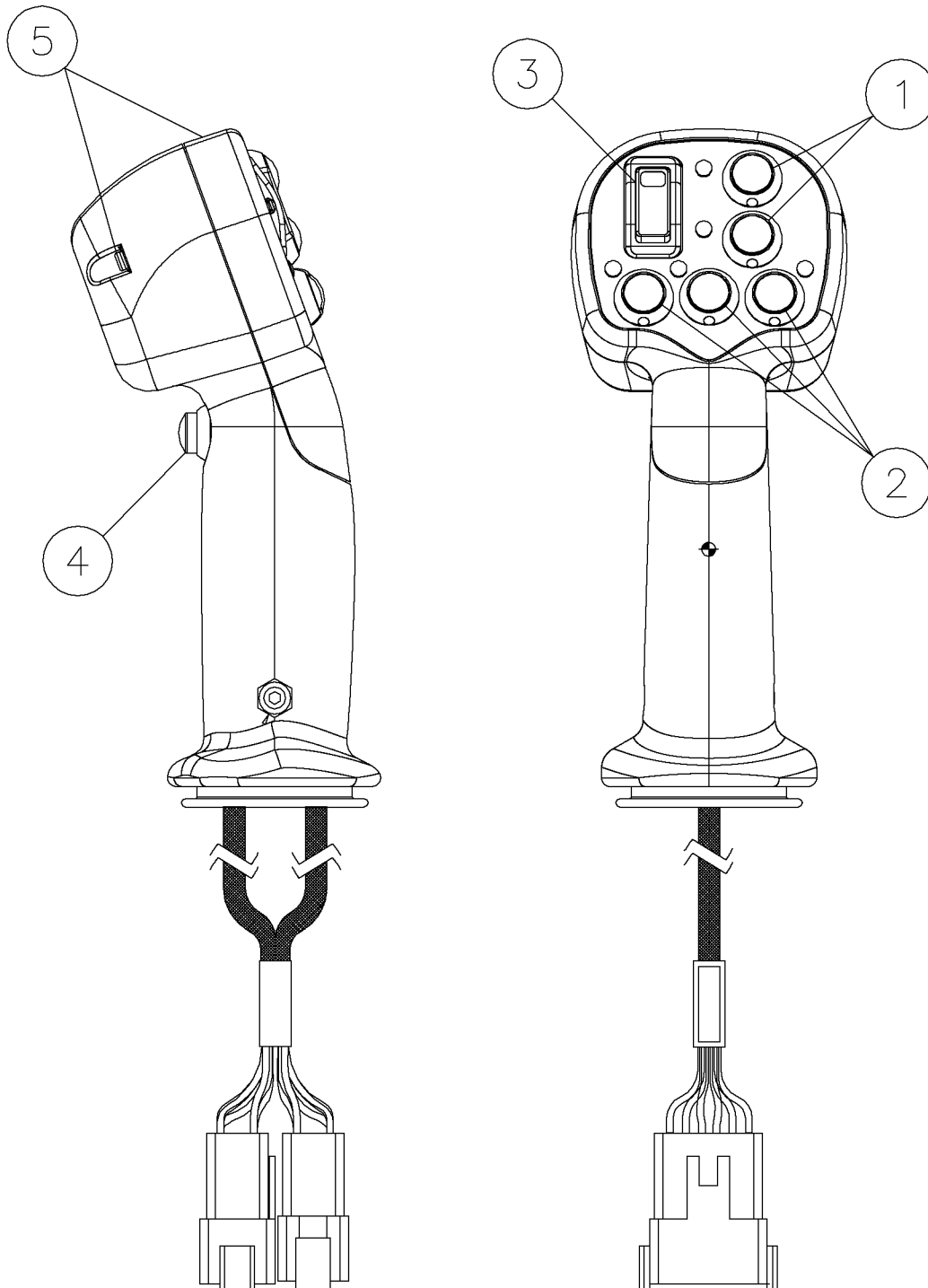

Illustration No. 296273907AC



## Components-Joystick Fig 4-10z01

REF. NO.	*	PART NO.	DESCRIPTION	QTY.	REMARKS
1		296271136	SWITCH	2	(Top-Throttle Increase)(Bottom-Throttle Decrease)
		296271135	BOOT -RUBBER	2	
2		296271137	SWITCH	3	(Left-Fluid Flow)(Middle-Auto Drill)(Right-Auto Grease)
		296271135	BOOT -RUBBER	3	
3		296271141	ROCKER SWITCH	1	Fluid On/Off
4		296271138	SWITCH	1	Not Used
5		296278211	FACE PLATE LEFT COVER	1	Includes Screw
		296278212	SCREW	2	
		296273907	HANDLE GRIP ASSEMBLY - LEFT JOYSTICK		Includes All Items In Figure

Joystick Panel-RH Fig 4-11

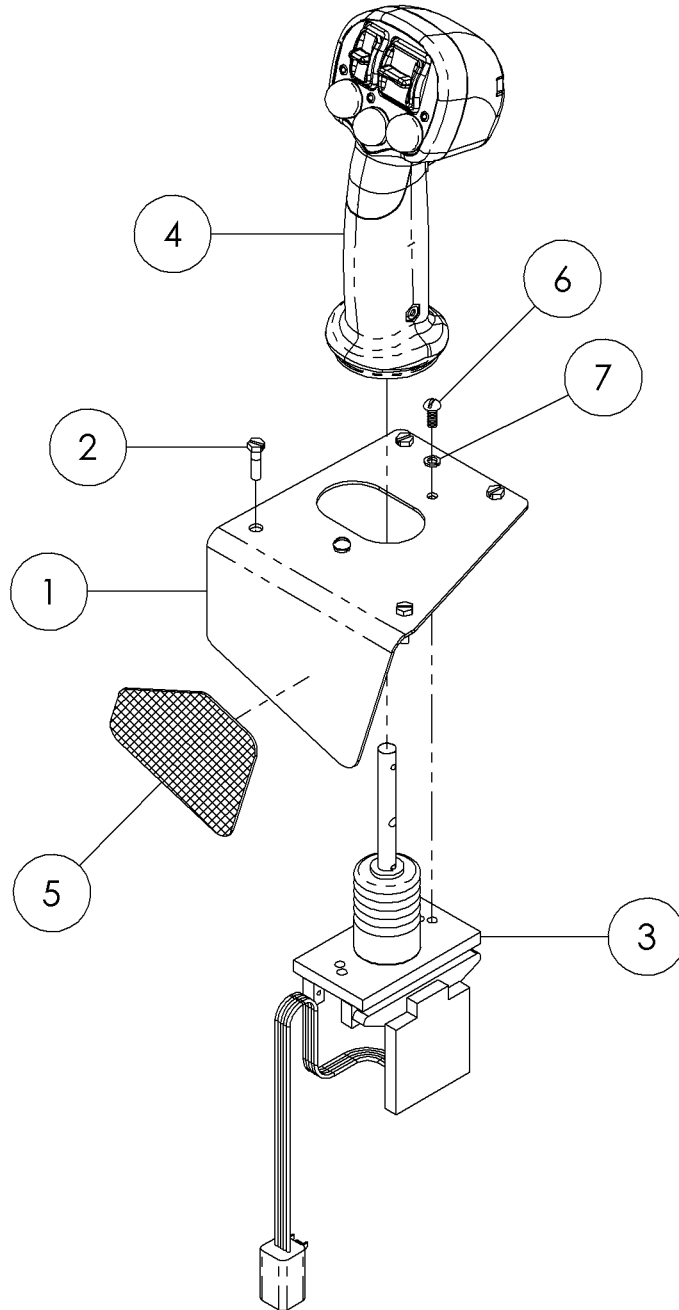

## Joystick Panel-RH Fig 4-11

REF. NO.	*	PART NO.	DESCRIPTION	QTY.	REMARKS
1		296284111	PLATE-JOYSTICK MOUNT RH	1	
2		510357010	SCREW-MCH-10-24X.75-GR2-YZ-HWH-SLOTTED	4	
3		296282533	JOYSTICK - SPRING CENTERED	1	
4		296273908	HANDLE GRIP ASSEMBLY - RIGHT JOYSTICK	1	Breakdown Fig. 4-11z01
5		700IC352	DECAL - CONTROL RIGHT HAND JOYSTICK	1	
6		1802004	BOLT-3/16"NF X 1/2" STOVE	2	
7		480001	WASHER-3/16 S/T LOCK	2	

Components-Joystick Fig 4-11z01

Illustration No. 296273908AC

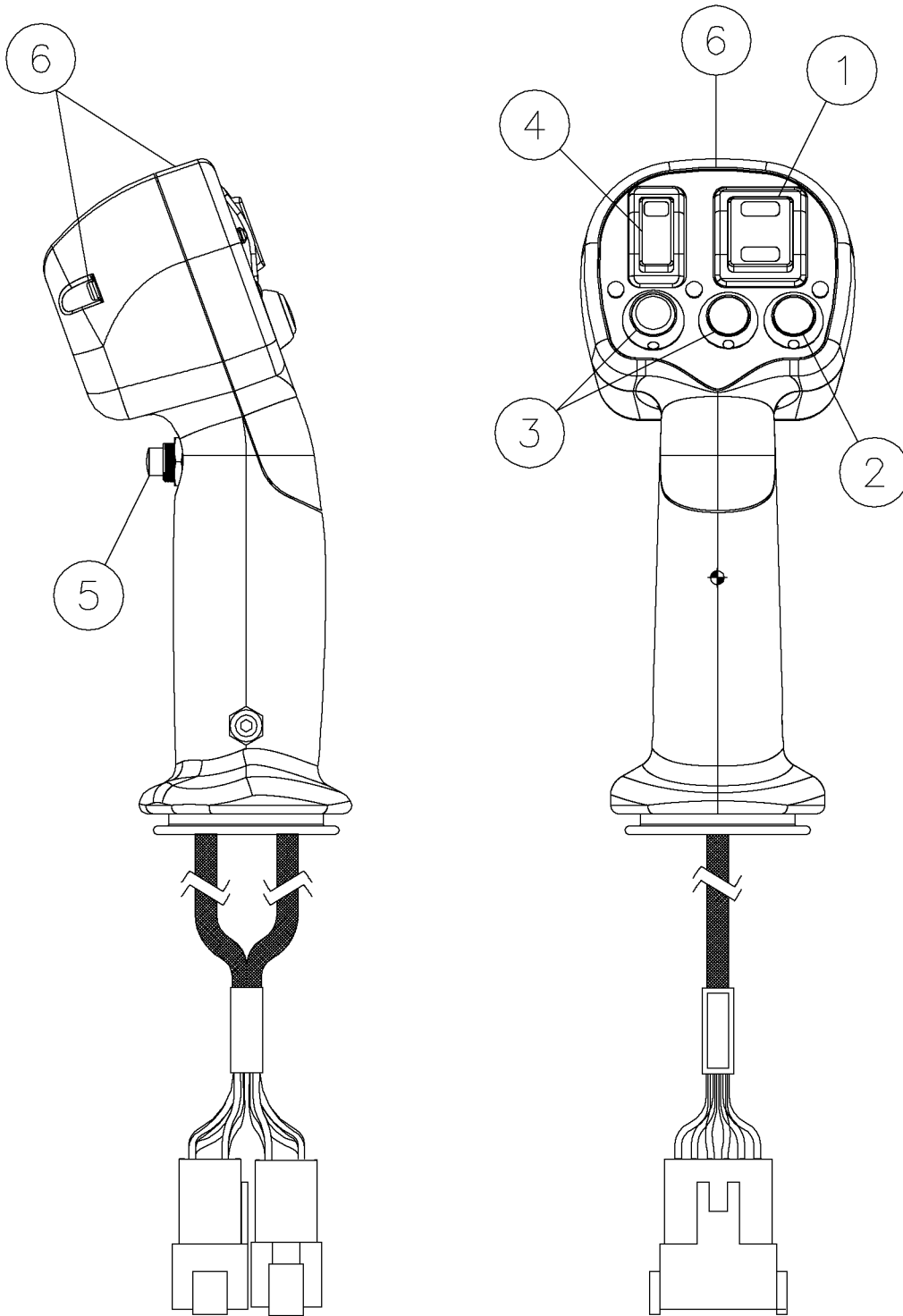

## Components-Joystick Fig 4-11z01

REF. NO.	*	PART NO.	DESCRIPTION	QTY.	REMARKS
1		296271142	ROCKER SWITCH	1	Front Vise
2		296271137	*SWITCH	1	
2		296271135	*BOOT -RUBBER	1	
3		296271139	*SWITCH	2	
3		296271135	*BOOT -RUBBER	2	
4		296271141	ROCKER SWITCH	1	Rear Vise
5		296271140	SWITCH	1	Rod Transfer Arm Retract
6		296285231	FACE PLATE- CONTROL	1	Includes Screw
6		296278212	SCREW	2	
		296273908	HANDLE GRIP ASSEMBLY-RIGHT JOYSTICK		Includes All Items In Figure

Battery Fig 4-12

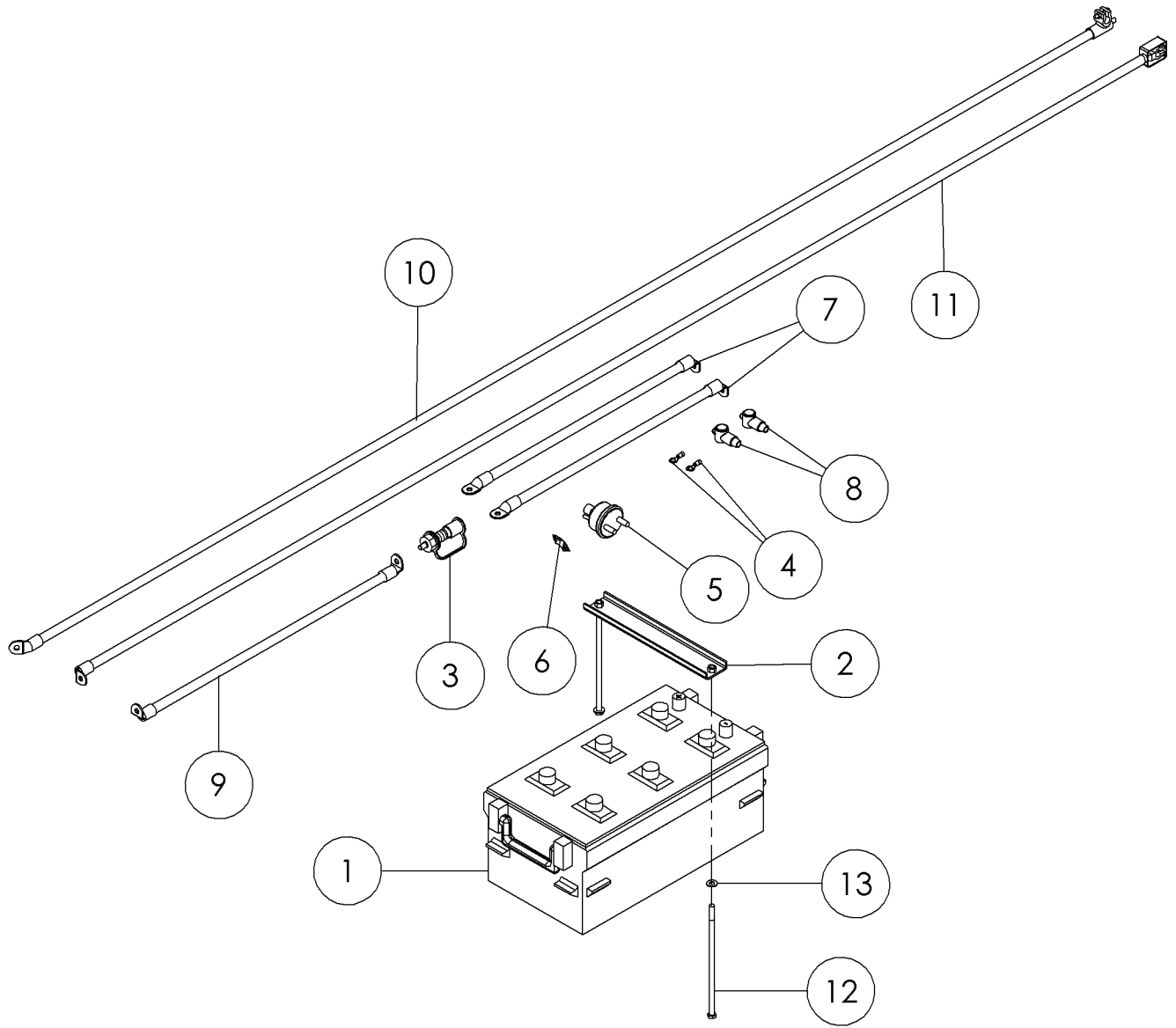

Illustration No. 296284100

## Battery Fig 4-12

REF. NO.	*	PART NO.	DESCRIPTION	QTY.	REMARKS
1		296266774	BATTERY - 12V 1400 CCA	1	
2		296286139	BATTERY HOLD DOWN	1	
3		206326001	TERMINAL-JUMPER/RED CAP(POS.)	1	
4		4716001	TERMINAL-3/8 RING 12-10 GA.	2	
5		904365001	*DISCONNECT SWITCH	1	Key Include
5		87356003	*KEY	A/R	(Pair)
6		700IC950	DECAL - CONTROL, BATTERY DISCONNECT	1	
7		296279963	CABLE - BATTERY 3/0-24" BLACK E-E-	2	
8		296269641	BOOT - BATTERY ALTERNATOR COVER	2	
9		296300482	BATTERY CAB 4/0	1	
10		296300481	BATTERY CAB 4/0	1	
11		296300483	BATTERY CAB 4/0	1	
12		296264100	SCREW - HCS - .38 - 16 X 10 GR8 0YZ	2	
13		235713001	WASHER-FLATSTRL-.38-.41X.81-.06-YA-A325	2	

Swing Cylinder/Valve Fig 4-13

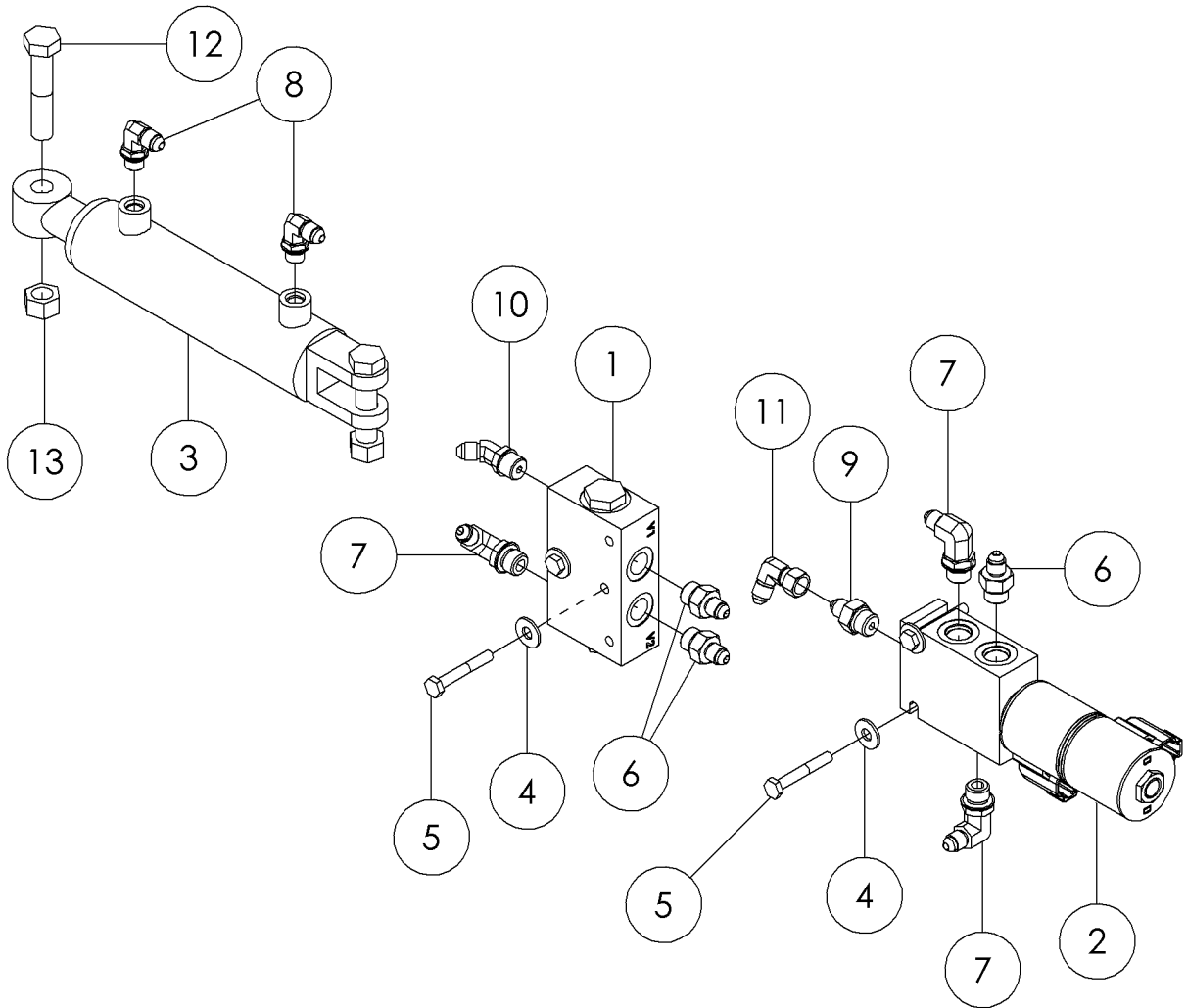

Illustration No. 296284101



## Swing Cylinder/Valve Fig 4-13

REF. NO.	*	PART NO.	DESCRIPTION	QTY.	REMARKS
1		205737001	CHECK VALVE-DOUBLE PILOT	1	
2		296269565	VALVE - 3 POSITION, 4 WAY DUAL SOL.	1	Breakdown Fig. 3-19z01
3		296280562	CYLINDER-1.50 BORE X4.50 STROKEX1.00 ROD	1	Breakdown Fig. 4-13z01
4		510337603	WASHER-FLATSTD-.25-.31X.75-.07-YZ	4	
5		248107001	BOLT-1/4-20X1 3/4 GR 8 ZINC PL	4	
6		57968001	FITTING-STR-4MJ-6MORB	3	
7		57950001	FITTING-90-4MJ-6MORBA	3	
8		59423001	FIT-4M JICX4M ADJ.90 DEG.ELBOW	2	
9		296303334	FITTING - STR-4MJ-4MORB-R.025	1	
10		82931001	FITTING-45-4MJX6MORBA	1	
11		53658001	FITTING-4M JICX4 FS JIC 90 DEG	1	
12		250573001	BOLT-1/2-13 X 2 1/2 GR8 HX Y/Z	2	
13		250512001	NUT- 1/2 NC Gr8 TOP LOCK Y/ ZINC	2	

Components-Swing Cylinder Fig 4-13z01

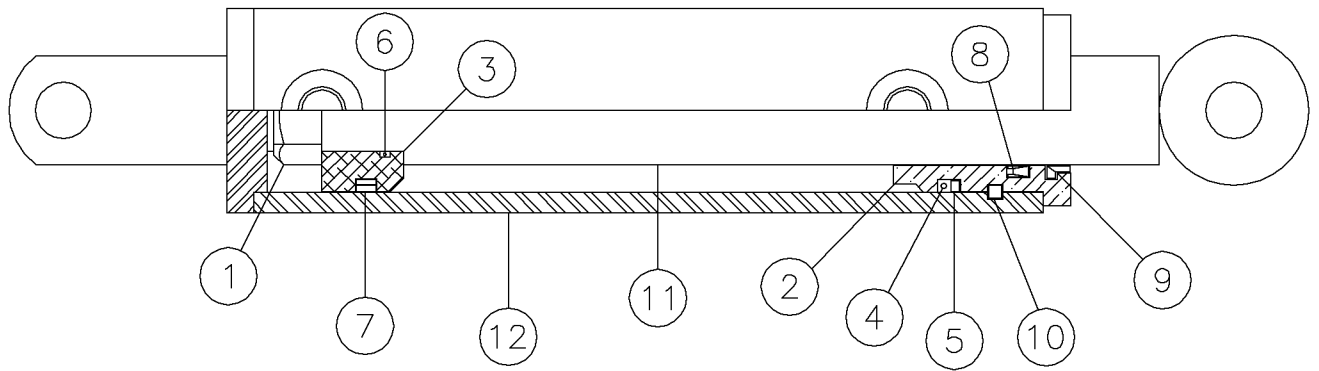

## Components-Swing Cylinder Fig 4-13z01

REF. NO.	*	PART NO.	DESCRIPTION	QTY.	REMARKS
1		296271158	NUT	1	
2		296271159	HEAD	1	
3		296271160	PISTON	1	
4			O-RING	1	Not Sold Separately
5			BACKUP	1	Not Sold Separately
6			O-RING	1	Not Sold Separately
7			PSP SEAL	1	Not Sold Separately
8			ROD SEAL	1	Not Sold Separately
9			DUST SEAL	1	Not Sold Separately
10		296271154	KEY STOCK	1	
11		296271161	SHAFT WITH CLEVIS	1	
12		296271162	BARREL WITH CLEVIS & PORTS	1	
		296280562	CYLINDER-1 1/2" X 4.5		Includes All Items In Figure
		296271163	SEAL KIT		Included Ref. 4-9

Blower/Duct Fig 4-14

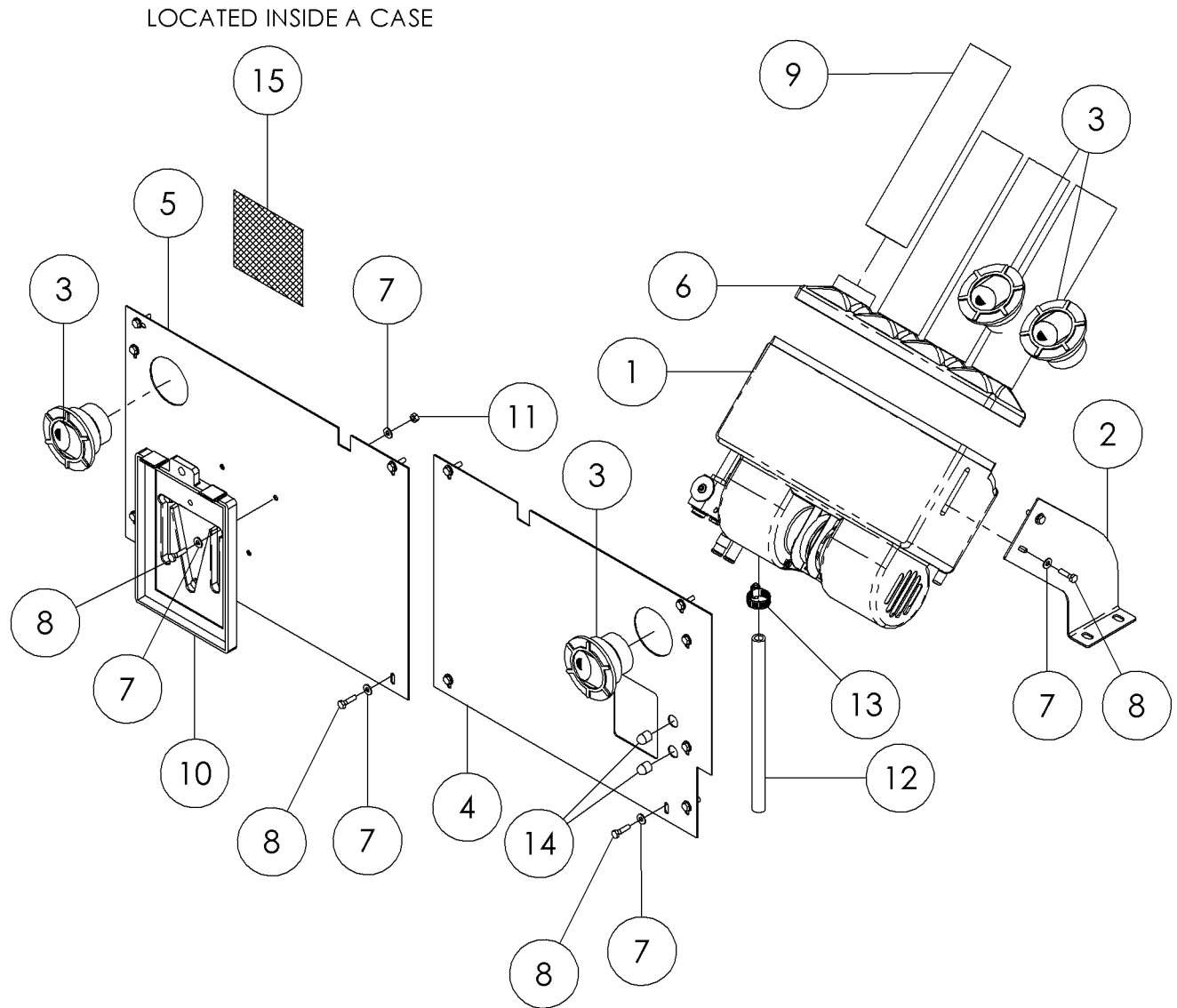

## Blower/Duct Fig 4-14

REF. NO.	*	PART NO.	DESCRIPTION	QTY.	REMARKS
1		296300421	BLOWER - HEAT/AC	1	
2		296300314	PLATE-BRACKET	2	
3		296300420	DIFFUSER-MULT DIRECTIONAL	4	
4		296300311	PLATE	1	
5		296300350	PLATE	1	
6		296300422	PLENUM - 4 HOLE	1	
7		235716001	WASHER-FLATSTRL-.25-.28X.63-.06-CZ	23	
8		235735001	BOLT-1/4-20X1 GR8 HEX ZYC	20	
9		296300419	HOSE- FLEX DUCT 2 1/2"	4	
10		142410001	CASE-6"X9 XCX X1" OPERATOR MANUAL	1	
11		235732001	NUT - HEX - .25 - 20 - GR8 - YZ	3	
12		296303335	HOSE - EVAPORATOR DRAIN - 15"	1	
13		1580005	HOSE CLAMP - 1"	1	
14		89597001	COVER-BREAKER SWITCH	2	
15		2326940	DECAL-NOTICE TO OWNERS	1	
		296256397	HOSE - HVAC COMPRESSOR TO EVAPORATOR	1	Not Shown

Rear Transport Station Fig 4-15

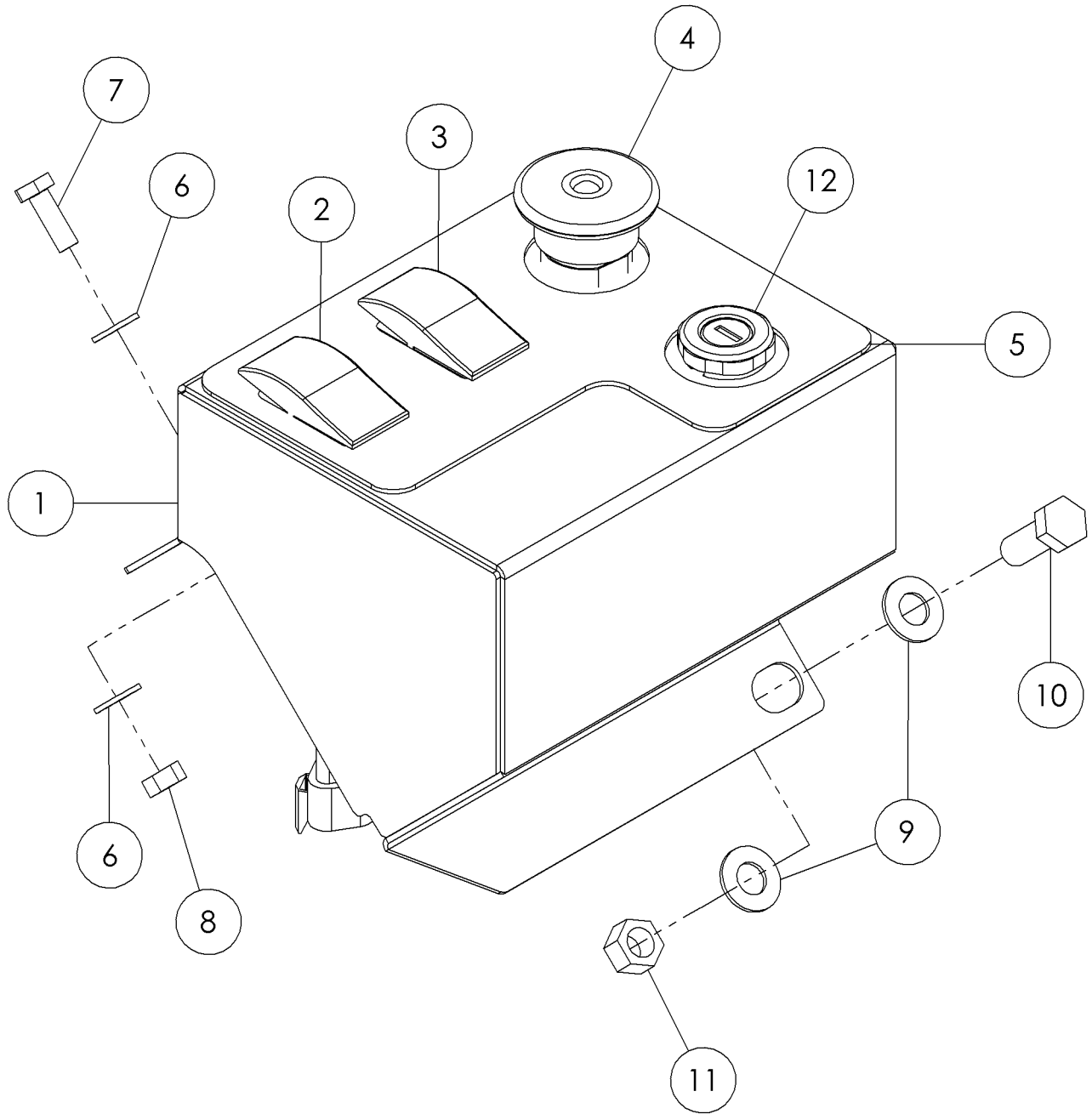

Illustration No. 296284105

## Rear Transport Station Fig 4-15

REF. NO.	*	PART NO.	DESCRIPTION	QTY.	REMARKS
1		296286236	REAR CONTROLS	1	
2		257541001	SWITCH-SPDT 3 POSITION MOM	1	
3		296279988	SWITCH - ON# ON ON#	1	
4		296259684	BUTTON - RED PUSH/PULL	1	
5		700ID500	DECAL - CONTROL REAR TRANSPORT	1	
6		235716001	WASHER-FLATSTRL-.25-.28 X .63 - .06 - CZ	4	
7		235734001	BOLT-1/4-20X3/4 GR8 ZYC	2	
8		235732001	NUT - HEX - .25 - 20 - GR8 - YZ	2	
9		235713001	WASHER - FLATSTRL - .38 - .41 X .81 - .06-YA-A325	2	
10		235727001	SCREW-HCS-.38-16X1.00-GR8-YZ	1	
11		235725001	NUT - HEX - .38 - 16 - GR8 - YZ	1	
12		285597001	SWITCH - IGNITION	1	Included Key
12		285597002	KEYS - IGNITION SWITCH (MATCHED PAIR)	A/R	

Row Selector Control Box Fig 4-16

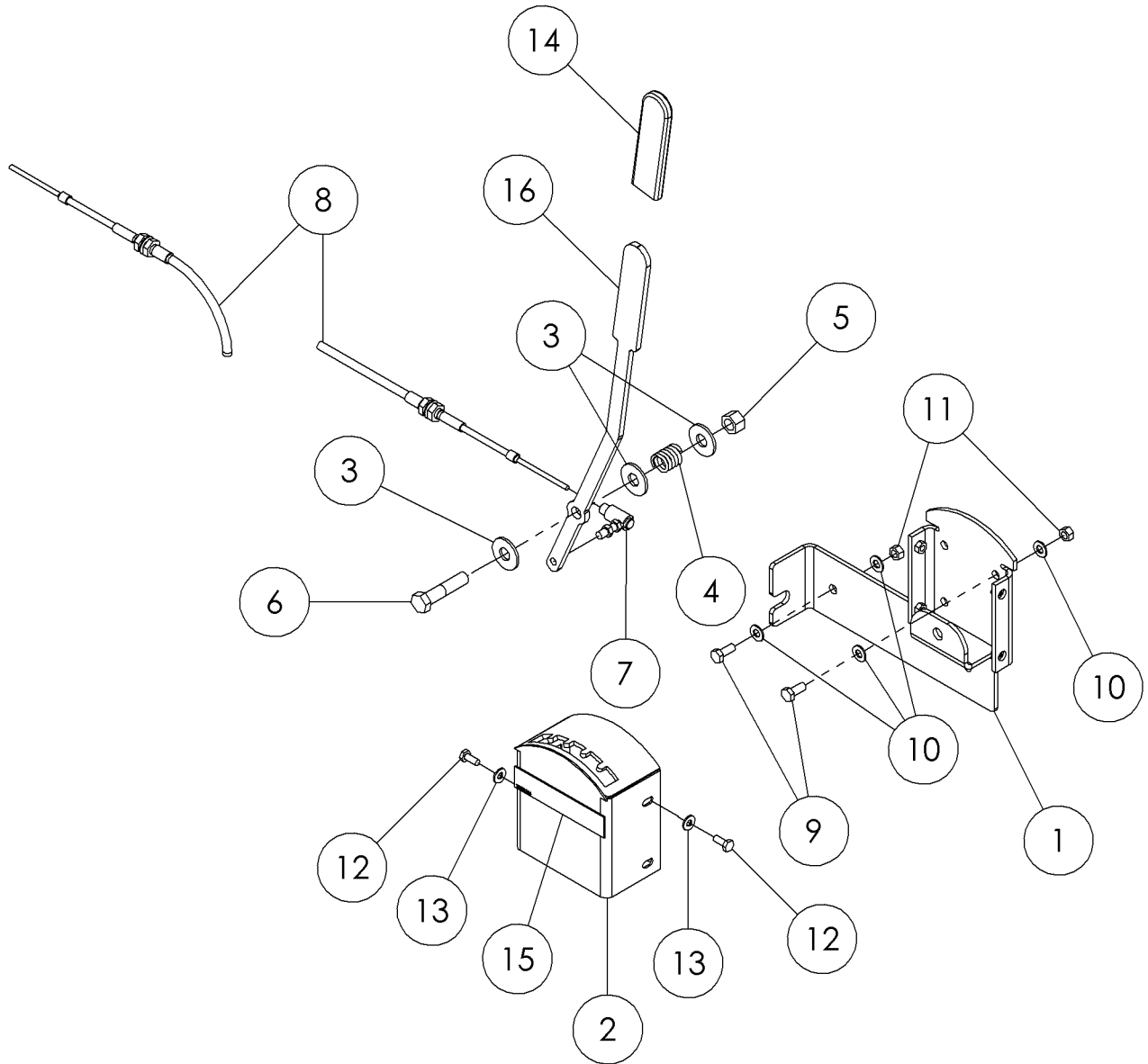

Illustration No. 296284113



Row Selector Control Box Fig 4-16

REF. NO.	*	PART NO.	DESCRIPTION	QTY.	REMARKS
1		296289010	WELDMENT - HANDLE BASE MOUNT	1	
2		296289011	WELDMENT - HANDLE COVER	1	
3		510337611	WASHER - FLATSTD - .50-.56X1.38-.11-YZ	3	
4		285776001	SPRING - COMP #49 1.00 O.A.	1	
5		510317501	NUT-TLHEX-.50-13-B-YZ	1	
6		240335001	SCREW-HCS-.50-13X2.25-GR8-YZ	1	
7		78653001	BALL JOINT 1/4FX5/16M A032267	1	
8		296300270	CABLE - 314-LTT-3-270	1	
9		235742001	BOLT-5/16-18X3/4 GR8 ZYC	6	
10		235714001	WASHER-FLATSTRL-.31-.34X.69-.06-YZ-A325	12	
11		235741001	NUT - HEX - .31 - 18 - GR8 -YZ	6	
12		284944001	SOCKET HD CAPSCREW - 1/4 - 20 UNC X 5/8	4	
13		235716001	WASHER-FLATSTRL-.25-.28X.63 - .06 - CZ	4	
14		258768001	HANDLE-PLASTIC (YELLOW)	1	
15		700ID254	DECAL - ROW SELECTOR	1	
16		296303293	PLATE - HANDLE	1	

Hood (S/N 582-) Fig 4-17r01

Illustration No. 296332540

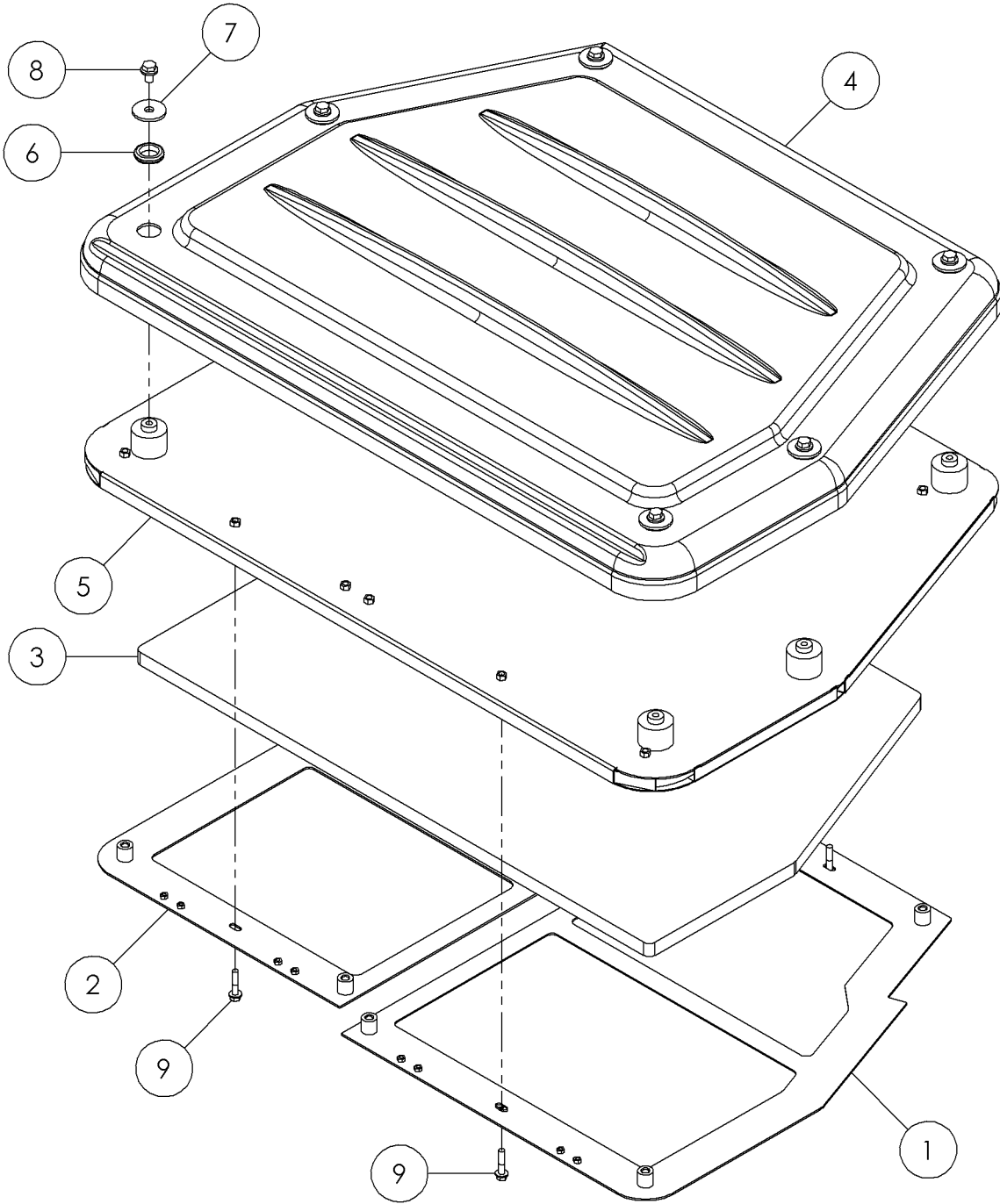

## Hood (S/N 582-) Fig 4-17r01

REF. NO.	*	PART NO.	DESCRIPTION	QTY.	REMARKS
1		296300345	ROOF SUPPORT-SUB	1	
2		296300344	ROOF SUPPORT-SUB	1	
3		296303266	FOAM - HEADLINER	1	
4		296332503	SHEET - CAB ROOF	1	
5		296332519	HEAD LINER WELDMENT	1	582-
6		224616001	GROMMET-1 1/4 ID X 1/8 GROOVE	6	582-
7		296332505	SLUG - CANOPY TOP	6	582-
8		296300873	SCREW-HFS-.50-13X.75-GR8-YZ	6	
9		296300775	SCREW-HFS-..38-16X1.75-GR8-YZ	4	
		296310864	CAB TRANSPORT COVER W/LINER		Not Shown

Hood (S/N 552-581) Fig 4-17

Illustration No. 296284115

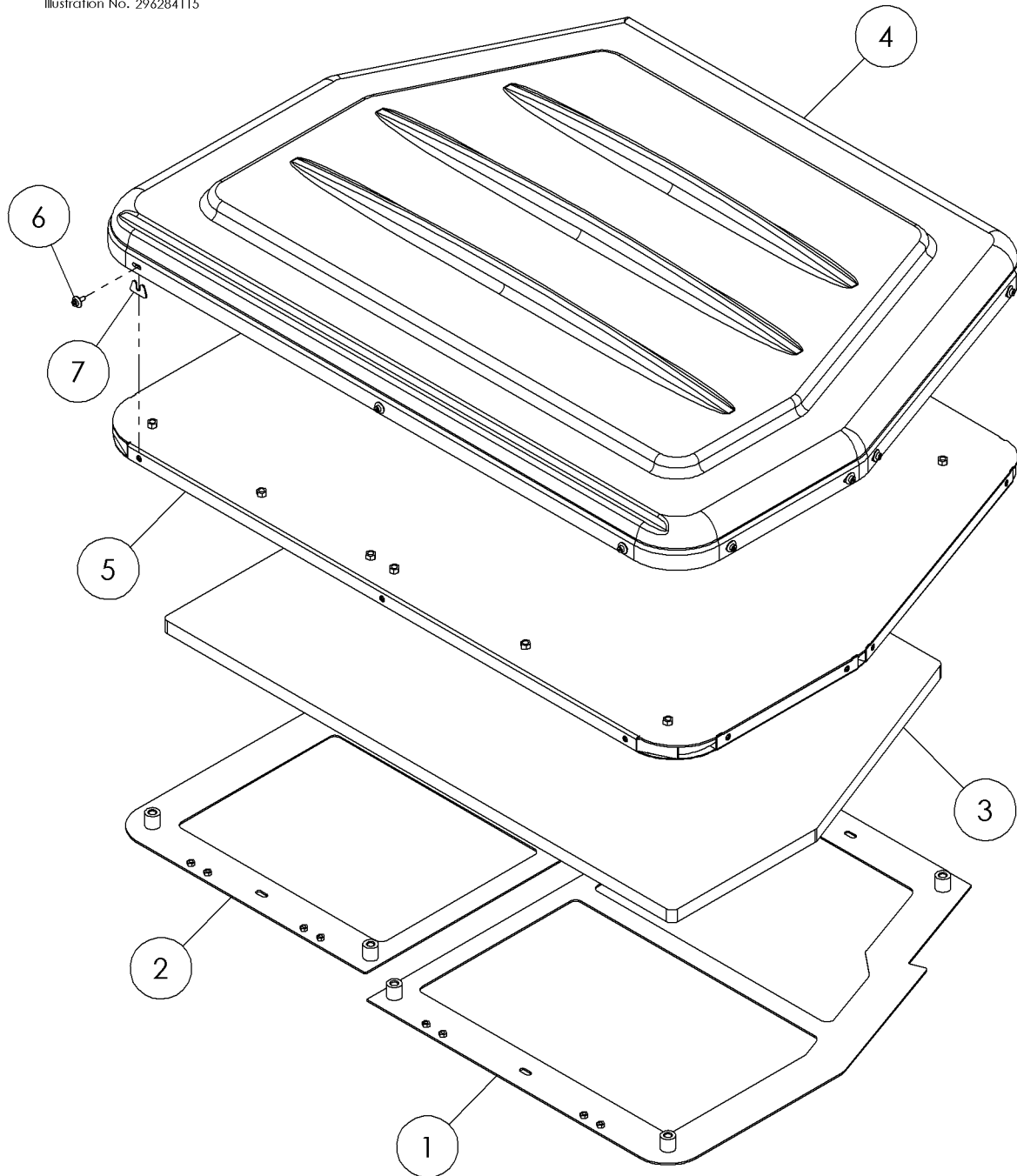

## Hood (S/N 552-581) Fig 4-17

REF. NO.	*	PART NO.	DESCRIPTION	QTY.	REMARKS
1		296300345	ROOF SUPPORT-SUB	1	
2		296300344	ROOF SUPPORT-SUB	1	
3		296303266	FOAM - HEADLINER	1	
4		296300326	SHEET-CAB ROOF	1	
5		296300400	HEAD LINER WELDMENT	1	
6		296290309	BOLT-SHOULDER 1/4-20UNC X 7/16 W/ 5/16 X 1/4 SHLDR	14	
7		296318045	SHIM - ROOF	14	
		296310864	CAB TRANSPORT COVER W/LINER		Not Shown

Kit-Headliner Panel Fig 4-18

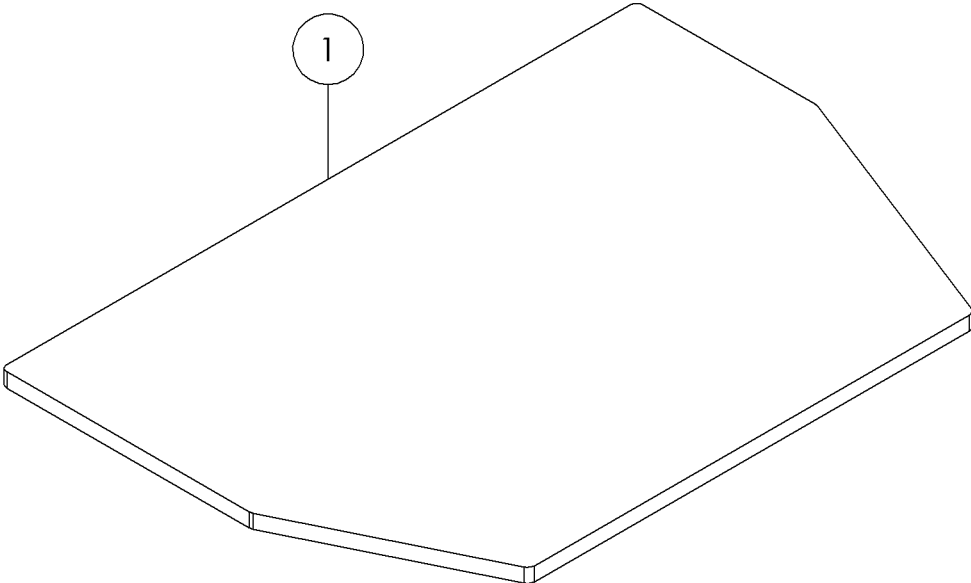
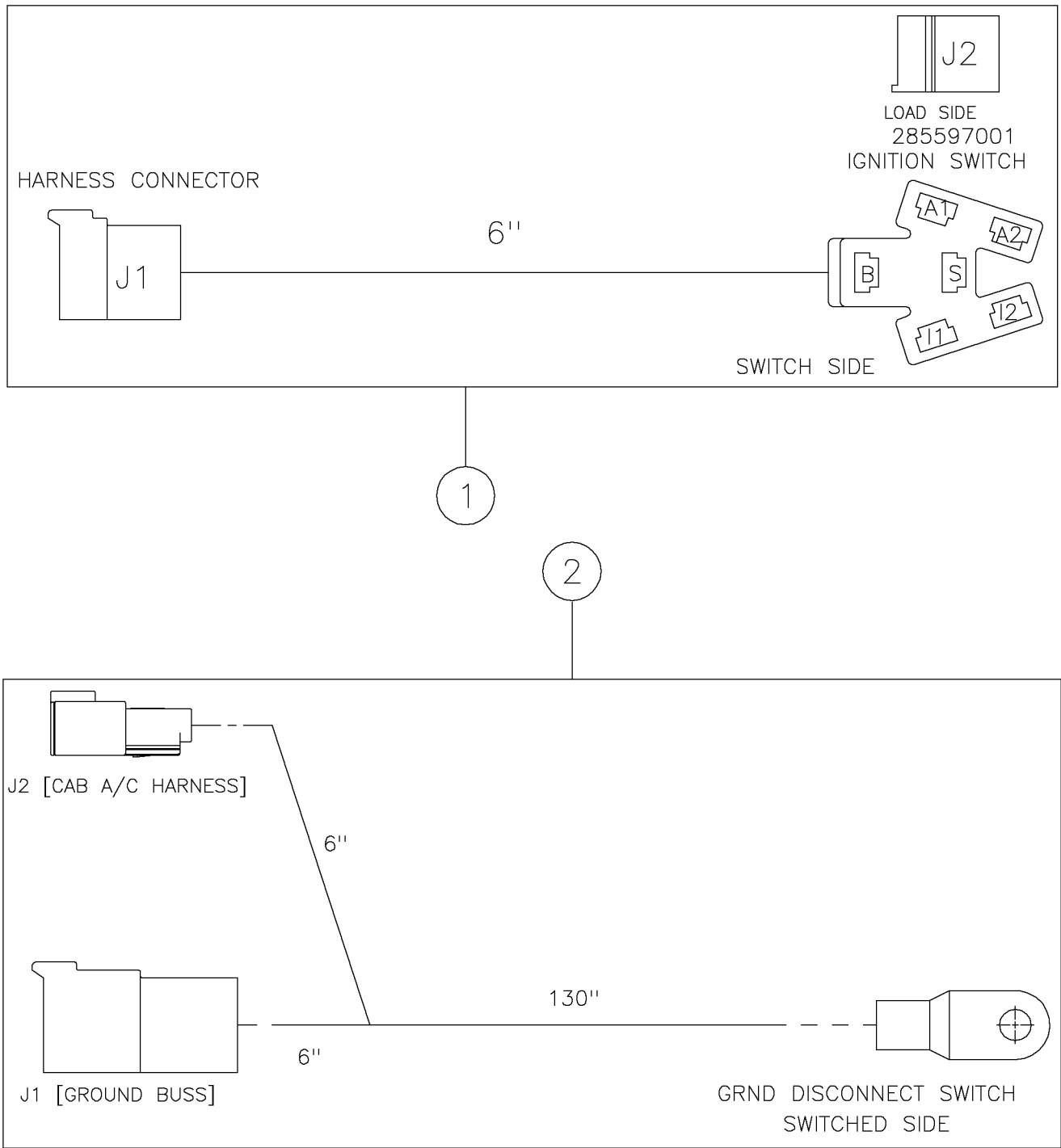

Illustration No. 296303338

Kit-Headliner Panel Fig 4-18

REF. NO.	*	PART NO.	DESCRIPTION	QTY.	REMARKS
1		296303266	FOAM - HEADLINER	1	

Harness-Keyswitch/Ground Lead Fig 4-19





Harness-Keyswitch/Ground Lead Fig 4-19

REF. NO.	*	PART NO.	DESCRIPTION	QTY.	REMARKS
1		296284076	HARNESS - KEYSWITCH ADAPTER	1	
2		296284118	HARNESS - GROUND LEAD	1	

Harness-Outrigger Fuel Fig 4-20

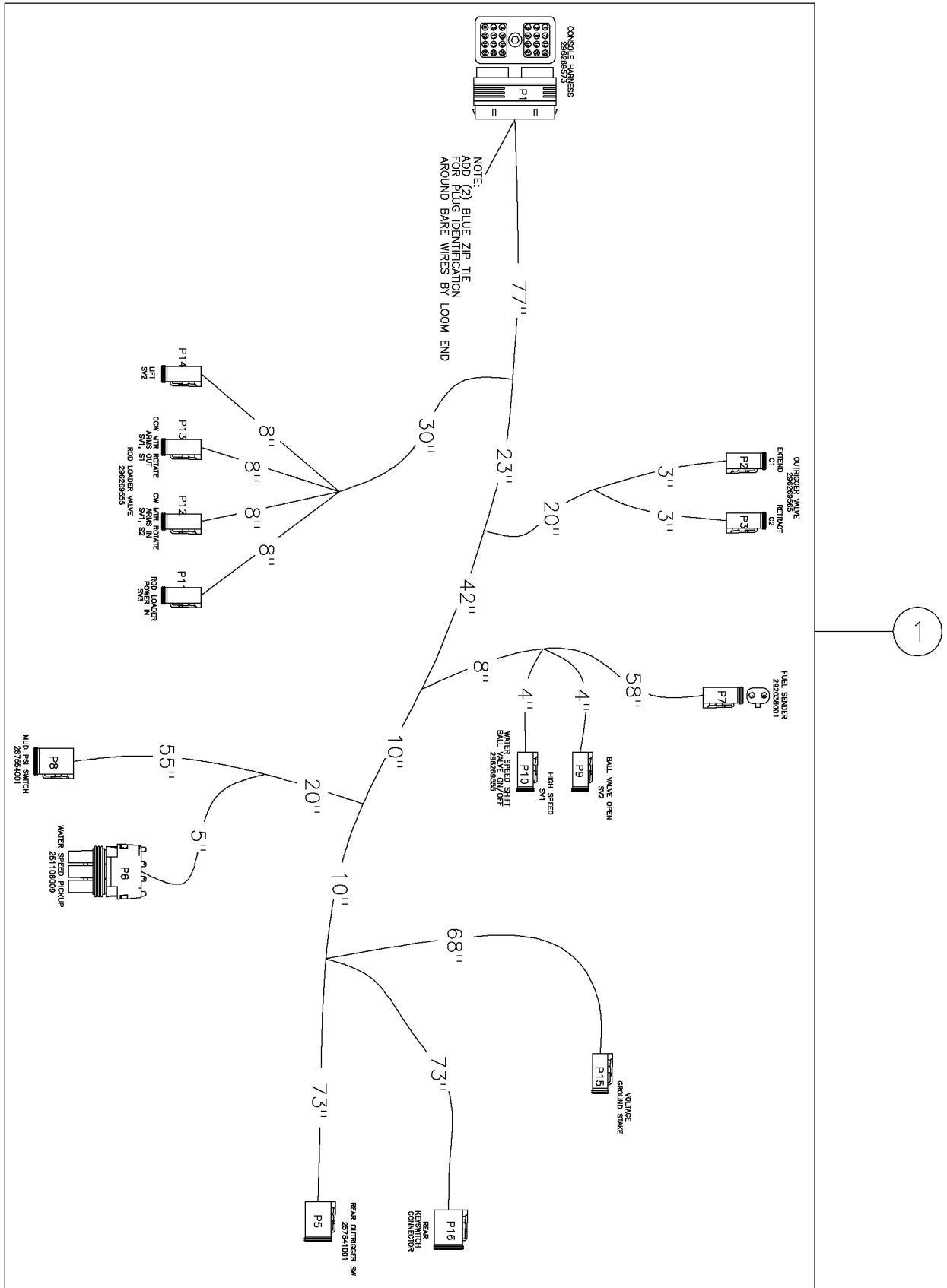

1

Harness-Outrigger Fuel Fig 4-20

REF. NO.	*	PART NO.	DESCRIPTION	QTY.	REMARKS
1		296284074	HARNESS-OUTRIGGER FUEL CAB	1	

Harness-Heat A/C Fig 4-21

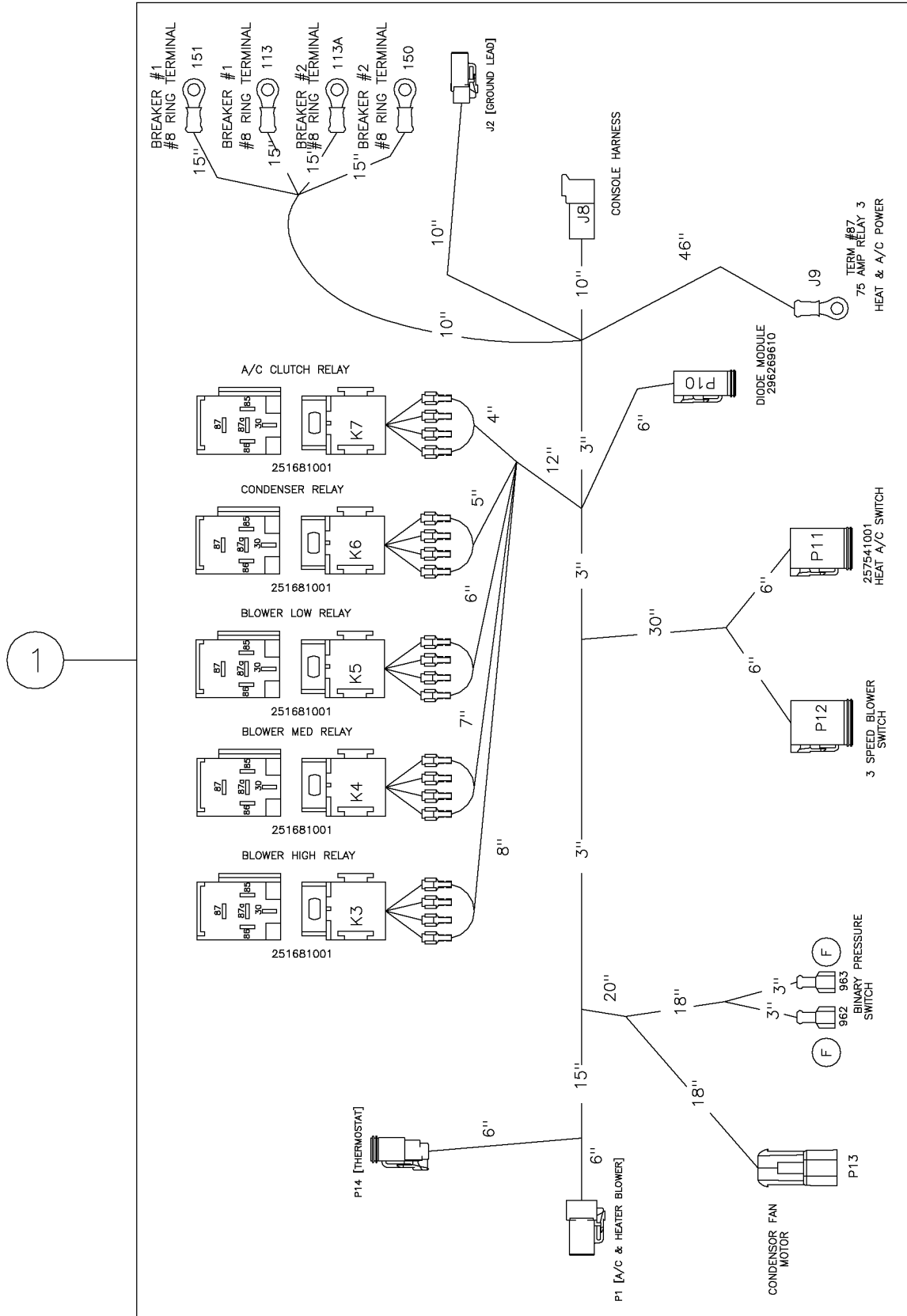

Harness-Heat A/C Fig 4-21

REF. NO.	*	PART NO.	DESCRIPTION	QTY.	REMARKS
1		296284140	HARNESS - HEAT A/C CAB	1	

Harness-Console Fig 4-22

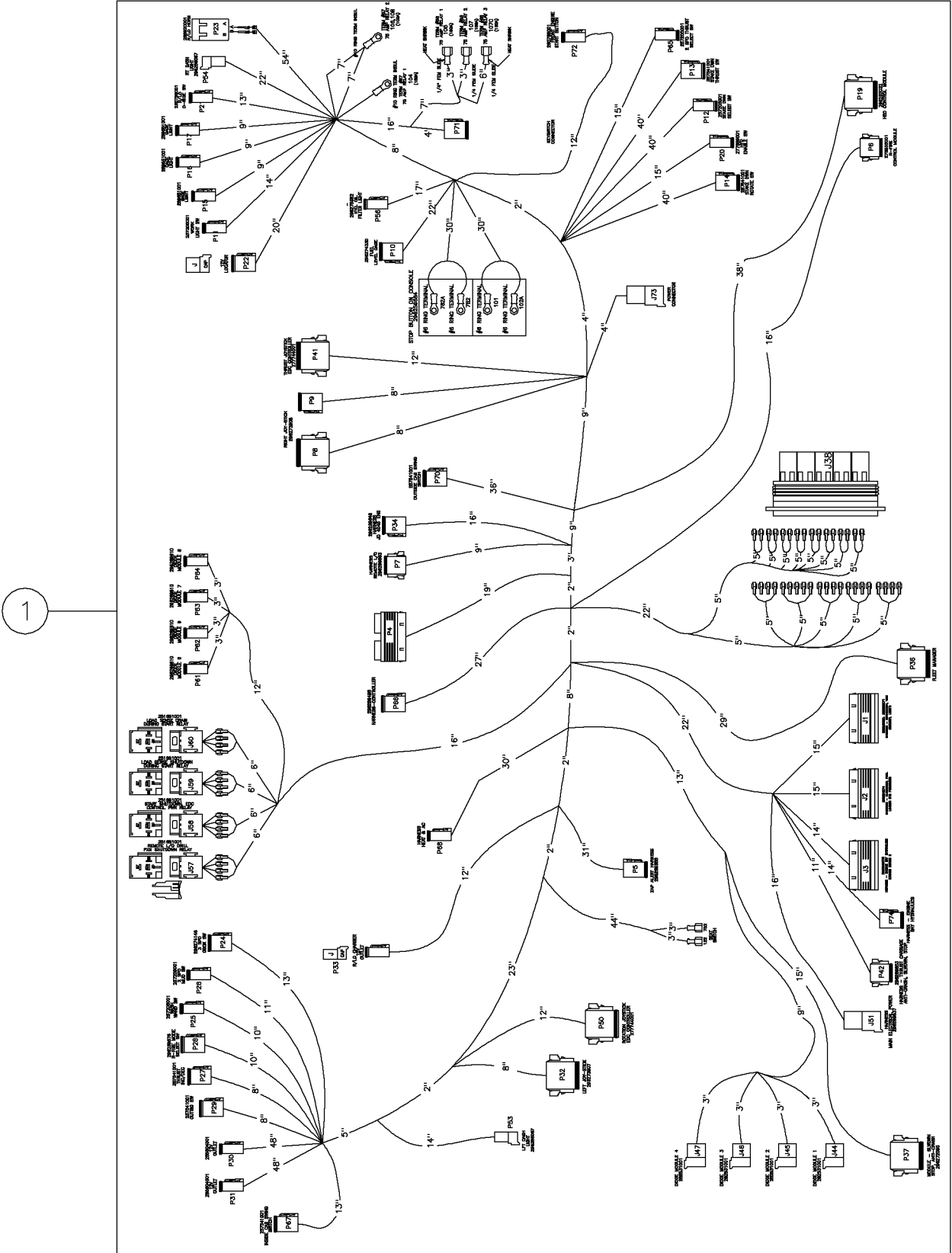

Harness-Console Fig 4-22

REF. NO.	*	PART NO.	DESCRIPTION	QTY.	REMARKS
1		296284141	HARNESS-CONSOLE CAB	1	

Harness-Engine Bay Fig 4-23

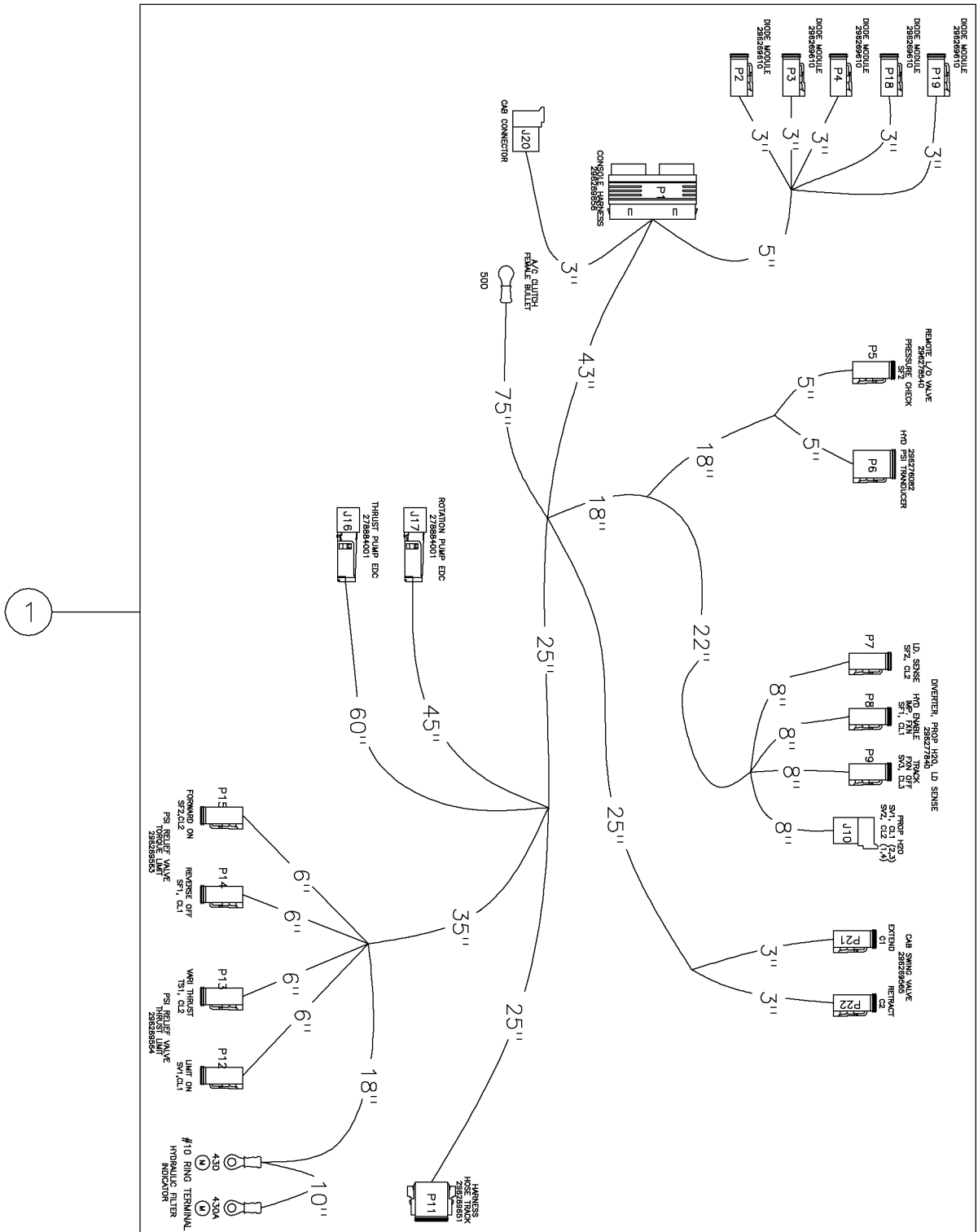



Harness-Engine Bay Fig 4-23

REF. NO.	*	PART NO.	DESCRIPTION	QTY.	REMARKS
1		296284142	HARNESS - ENGINE BAY CAB	1	

Harness-Power Distribution Fig 4-24

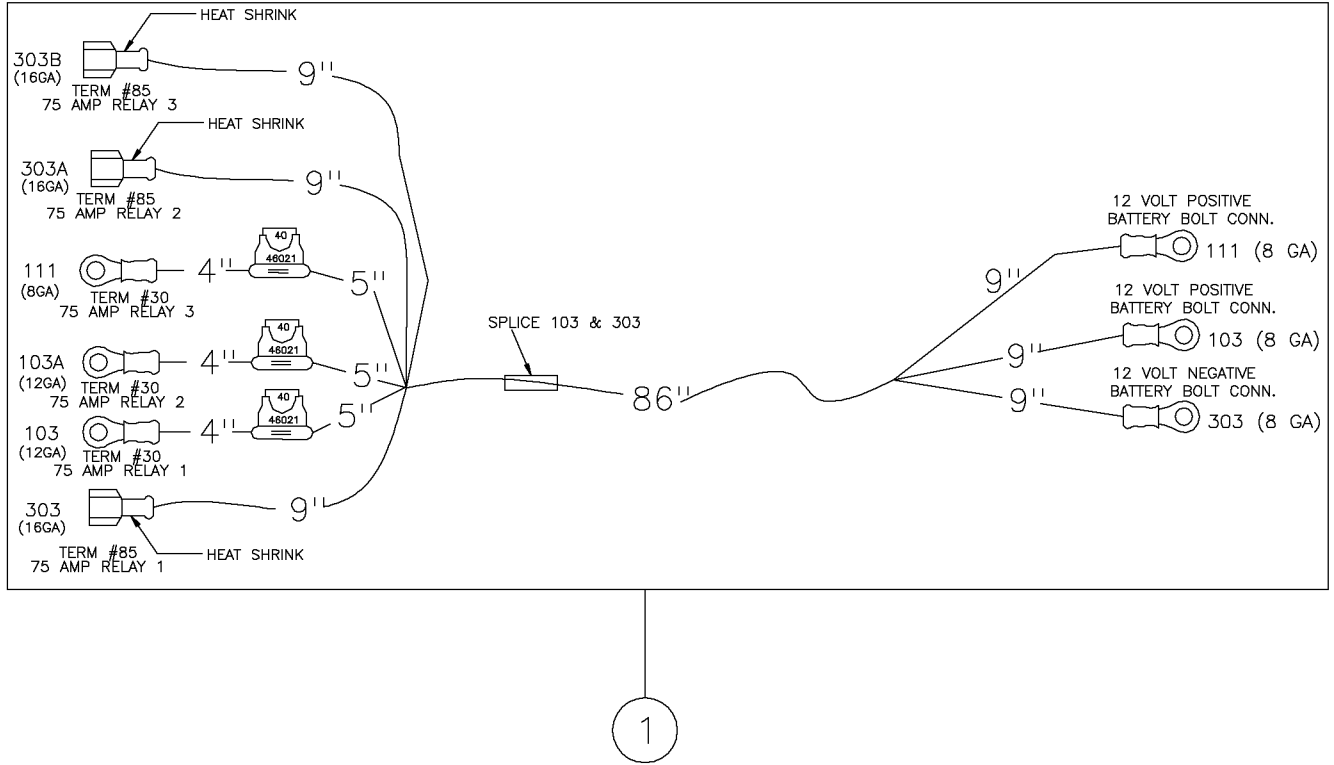

Harness-Power Distribution Fig 4-24

REF. NO.	*	PART NO.	DESCRIPTION	QTY.	REMARKS
1		296293082	HARNESS - POWER DISTRIBUTION	1	

Harness-Cab Swing / 24 Way Extension Fig 4-25

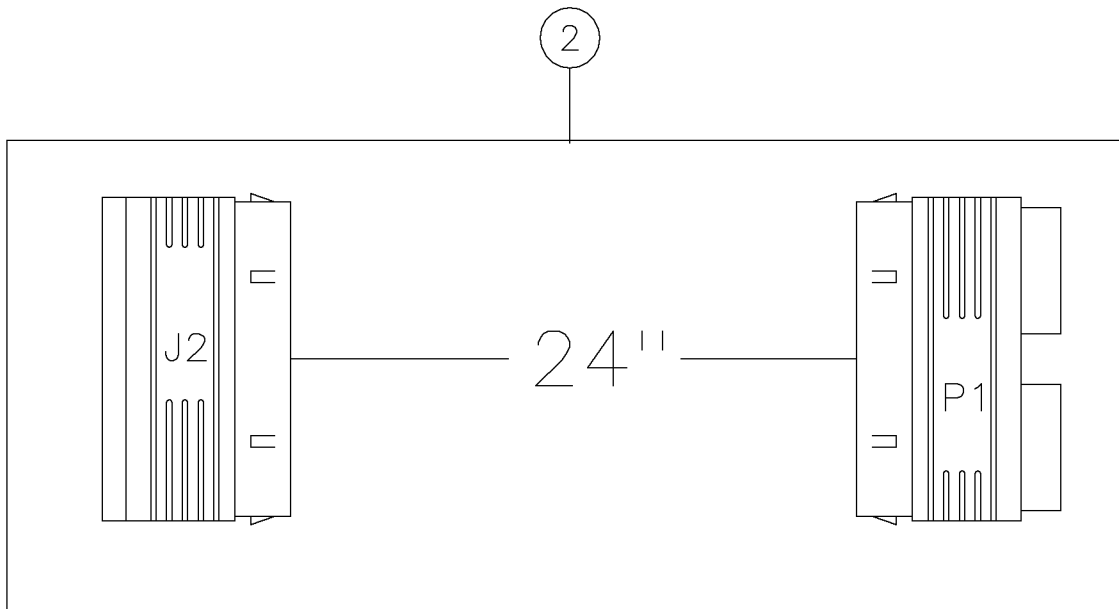
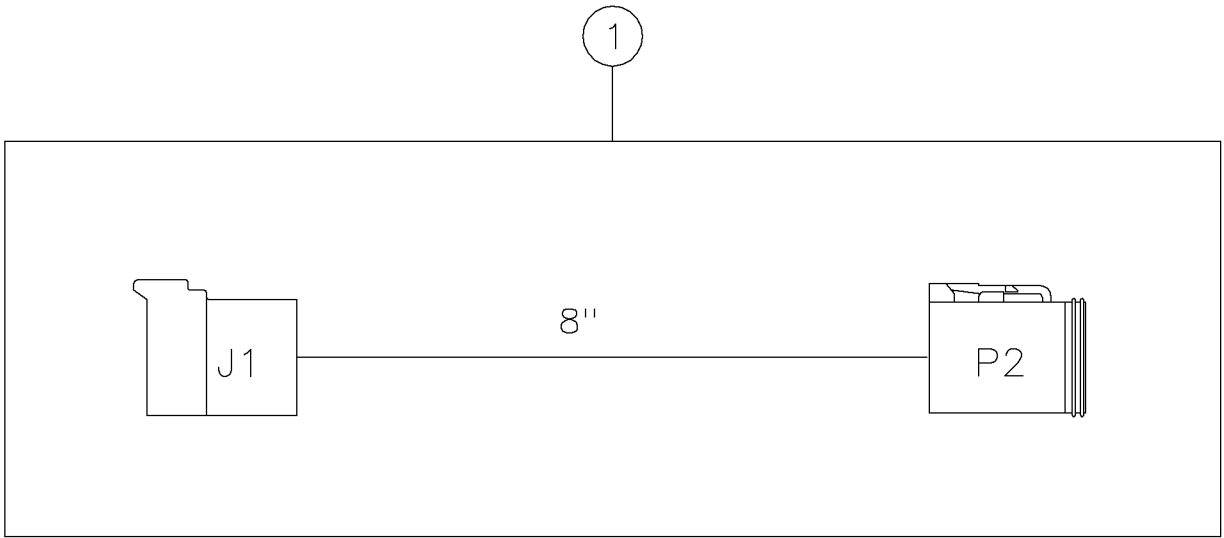

Harness-Cab Swing / 24 Way Extention Fig 4-25

REF. NO.	*	PART NO.	DESCRIPTION	QTY.	REMARKS
1		296293122	HARNESS CAB SWING DIODE	1	
2		296293083	HARNESS - 24 WAY EXTENSION	1	

Heater Plumbing Fig 4-26

Illustration No. 296303429

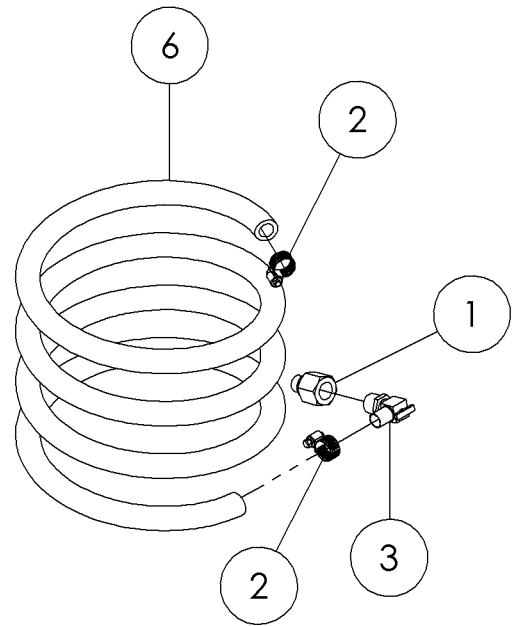
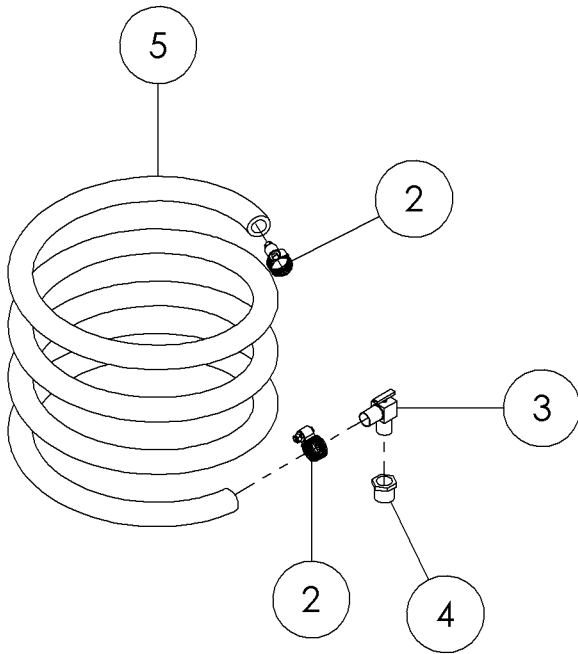

## Heater Plumbing Fig 4-26

REF. NO.	*	PART NO.	DESCRIPTION	QTY.	REMARKS
1		296300411	FITTING M18 X 1/2" FNPT ST	1	
2		1580003	HOSE CLAMP - 3/4"	4	
3		82633001	FITTING-HEATER SHUT-OFF	2	
4		730005	FITTING-BSHG-8MNPT-6FNPT-HEX	2	
5		296310993	HOSE 5/8" HEATER - 142" LG	1	
6		296310994	HOSE 5/8" HEATER - 163"LG	1	

Blower Electrical Fig 4-27

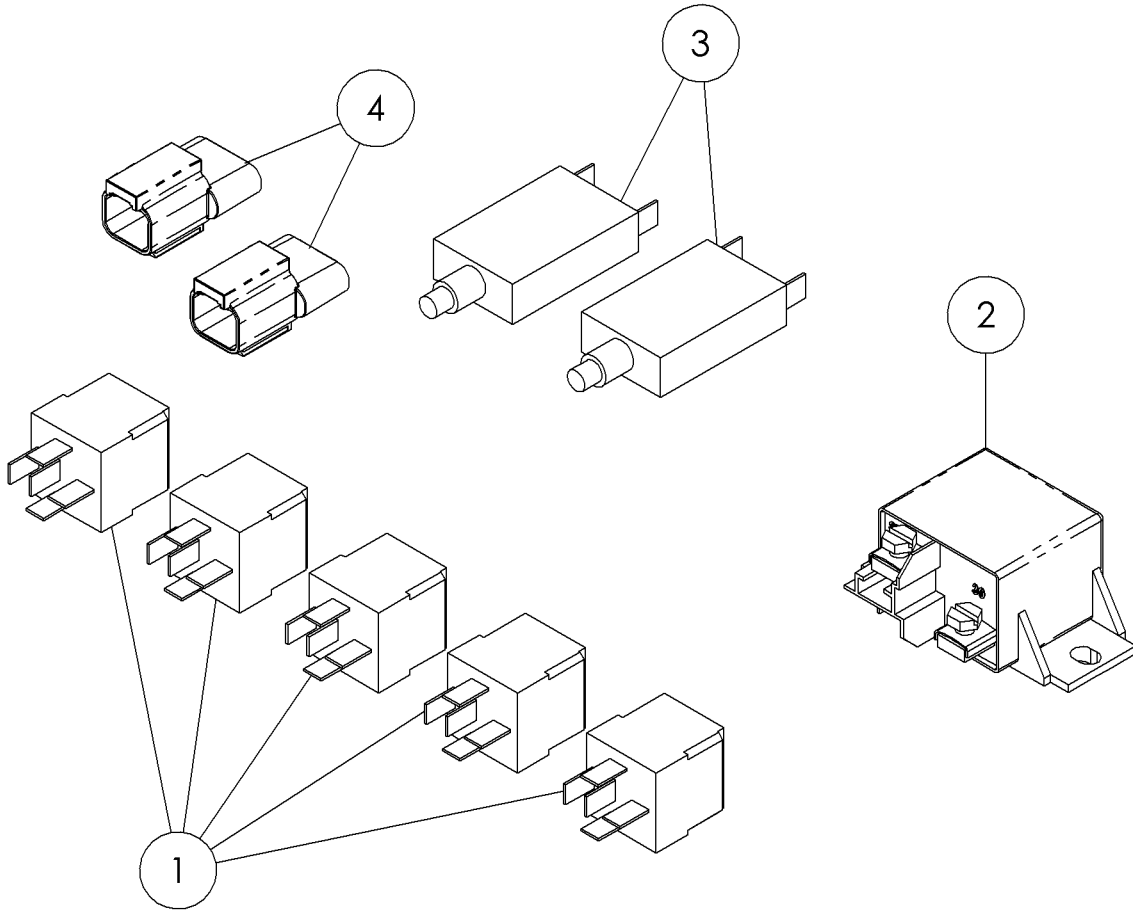



## Blower Electrical Fig 4-27

REF. NO.	*	PART NO.	DESCRIPTION	QTY.	REMARKS
1		251681001	RELAY - SEALED 40 AMP	5	
2		86217001	RELAY-BOSCH SPST 75 AMP SEALED	3	
3		72082001	BREAKER 2-5700--514-DD 22 AMP	2	
4		296269610	MODULE-DEUTSCH DT04-4P 3AMP DIODE	2	

A/C Condenser Fig 4-28

Illustration No. 296284103

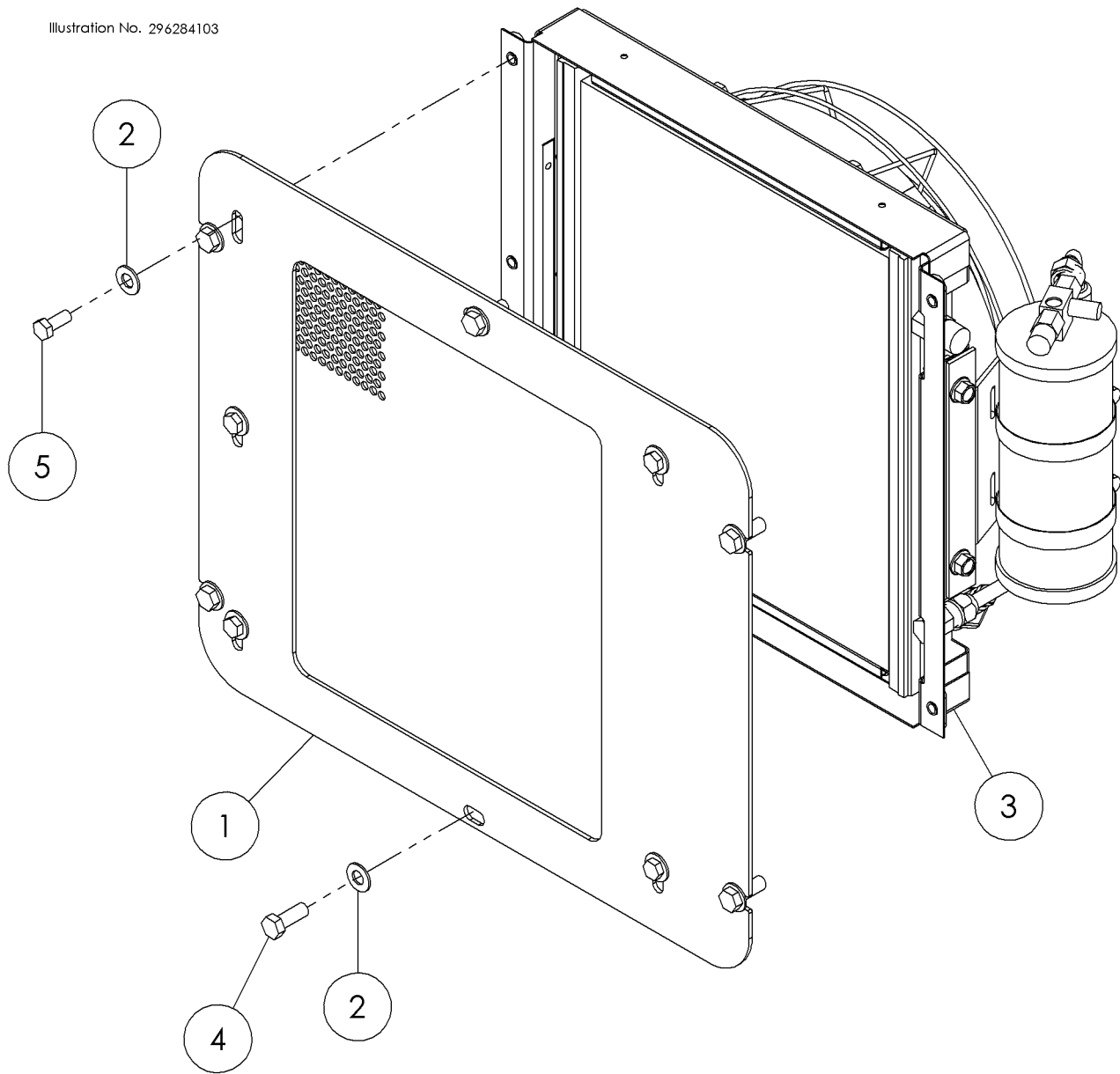

## A/C Condenser Fig 4-28

REF. NO.	*	PART NO.	DESCRIPTION	QTY.	REMARKS
1		296314302	AC CONDENSOR COVER ASSY	1	
2		235713001	WASHER-FLATSTRL-.38-.41X.81-.06-YA-A325	11	
3		296300289	CONDENSER-A/C CAB	1	
3		296319539	RECEIVER/DRYER	1	
4		235727001	SCREW-HCS-.38-16X1.00-GR8-YZ	6	
5		506032020	SCREW-HCS,M8-1.25X20,8.8,YZ,D933,FT	5	
		296256396	HOSE - HVAC CONDENSER TO COMPRESSOR	1	Not Shown
		296256398	HOSE - HVAC CONDENSER TO DRYER	1	Not Shown

A/C Compressor Fig 4-29

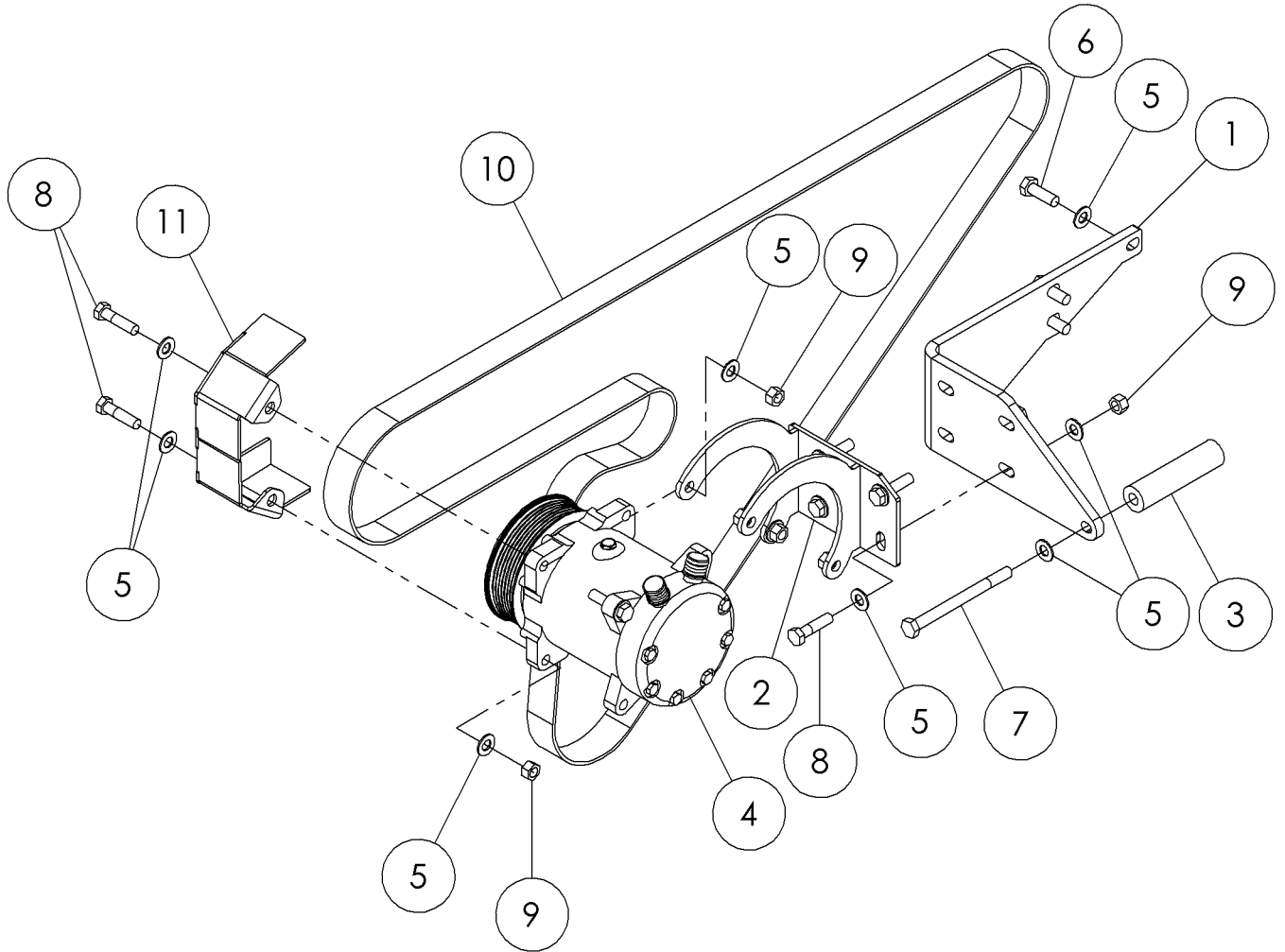
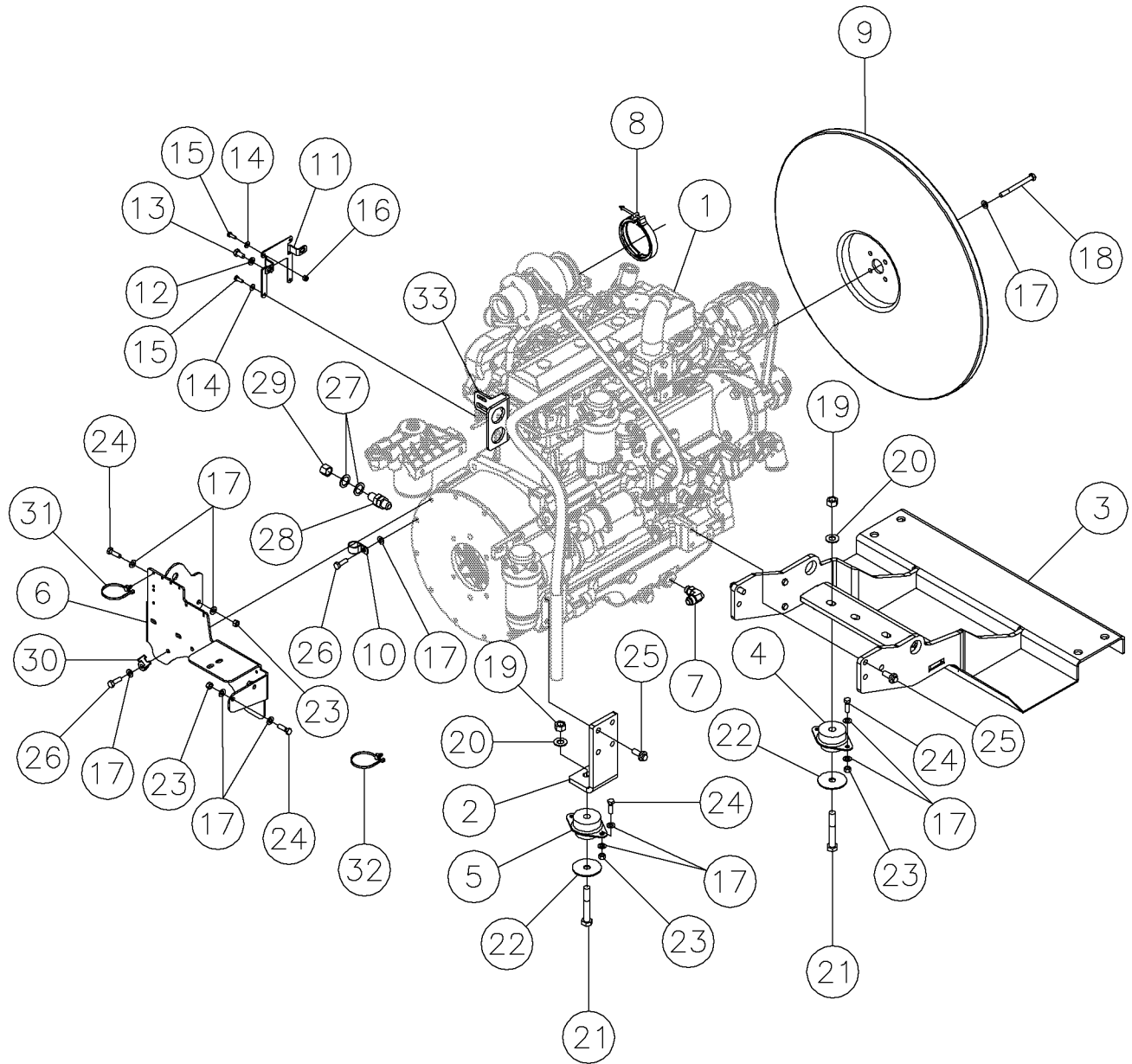

Illustration No. 296284104

## A/C Compressor Fig 4-29

REF. NO.	*	PART NO.	DESCRIPTION	QTY.	REMARKS
1		296300263	PLATE-COMPRESSOR MOUNT	1	
2		296300266	COMPRESSOR MOUNT WELDMENT	1	
3		296300264	TUBE-COMPRESSOR SPACER	1	
4		617678001	A/C COMPRESSOR - 8 GROOVE PULLEY	1	
5		235713001	WASHER-FLATSTRL-.38-.41X.81-.06-YA-A325	22	
6		508476030	SCREW-HCS,M10-1.50X30,10.9,YZ,ISO4017,FT	3	
7		507092120	SCREW-HCS,M10-1.50X120,8.8,YZ,ISO4014,PT	1	
8		235723001	SCREW - HCS -.38 - 16 X 1.50 - GR8 - YZ	9	
9		235725001	NUT - HEX - .38 - 16 - GR8 - YZ	9	
10		296284114	BELT-2590MM FAN W/AC	1	
11		296308543	BELT GUARD	1	
		296303317	HOSE-A/C CONDENSER TO COMPRESSER	1	Not Shown
		296303318	HOSE-A/C COMPRESSER TO EVAPORATER	1	Not Shown
		296303339	HOSE-HEAT WRAP 7/8 X 6.0	1	Not Shown
		296303340	HOSE-HEAT WRAP 1.25 X 6.0	1	Not Shown
		296303341	HOSE-HEAT WRAP 2.0 X 18.0	1	Not Shown

Engine/Mounting Fig 5-1



## Engine/Mounting Fig 5-1

REF. NO.	*	PART NO.	DESCRIPTION	QTY.	REMARKS
1		296269735	ENGINE-TIER III 140 HP JD 4045H	1	Breakdown Fig. 5-1z01 & 5-1z02
2		296274655	PLATE - ENGINE SUPPORT	2	
3		296280416	MOUNT - FRONT ENGINE	1	
4		296274660	ISOLATOR - ENGINE WHITE	2	
5		296274659	ISOLATOR - ENGINE RED	2	
6		296274626	BRACKET - OIL FILTER	1	
7		100351001	FITTING-90-10MJ-M18X1.5MORBA	1	
8		285687001	CLAMP - MUFFLER/TURBO	1	
9		296280871	COOLING FAN - 28.25" BLOWER	1	
10		2595009	CLAMP-1 1/4 HOSE #7701164	1	
11		296289044	PLATE - ECU MOUNT	1	
12		506046010	WASHER-FLAT,M10,YZ,D125A	2	
13		507092020	SCREW-HCS,M10-1.50X20,8.8,YZ,ISO4017,FT	2	
14		235716001	WASHER - FLATSTRL - .25 -.28 X .63 - .06 - CZ	4	
15		235734001	BOLT-1/4-20X3/4 GR8 ZYC	4	
16		103201001	NUT-1/4-20NC NYLON INSERT LOCK	4	
17		235713001	WASHER - FLATSTRL - .38 - .41 X .81 - .06-YA-A325	36	
18		508476110	SCREW-HCS,M10-1.50X110,10.9,YZ,ISO4014,PT	4	
19		250513001	NUT - 5/8NC Gr8 TOP LOCK Y/ZINC	4	
20		235715001	WASHER-FLATSTRL-5/8" YZ A325	4	
21		27169040	BOLT-5/8-11UNCX4 GR.8 HEX	4	
22		220203001	SLUG-ENGINE MOUNT	4	
23		250508001	NUT - 3/8-NC Gr8 TOP LOCK Y/ZINC	12	
24		235736001	BOLT-3/8-16X1 1/4 ZYC	12	
25		507613030	SCREW-HFS,M12-1.75X30,10.9,YZ,ANSI,B18.2.3.9M,PT	14	
26		508476030	SCREW-HCS,M10-1.50X30,10.9,YZ,ISO4017,FT	8	
27		240756001	WASHER-SERRAID 1 3/8 ODX7/8ID	2	
28		77734001	FITTING-10M JIC BULKHEAD STR.	1	
29		78062001	FITTING - CAP - 10FJ	1	
30		296276018	MOUNT HELLER MANN TITON	3	
31		296276007	FIR TREE MOUNT	1	
32		59634001	SINGLE NYTIE - 8"	1	
33		296272993	BRACKET	1	

Components-Engine Fig 5-1z01

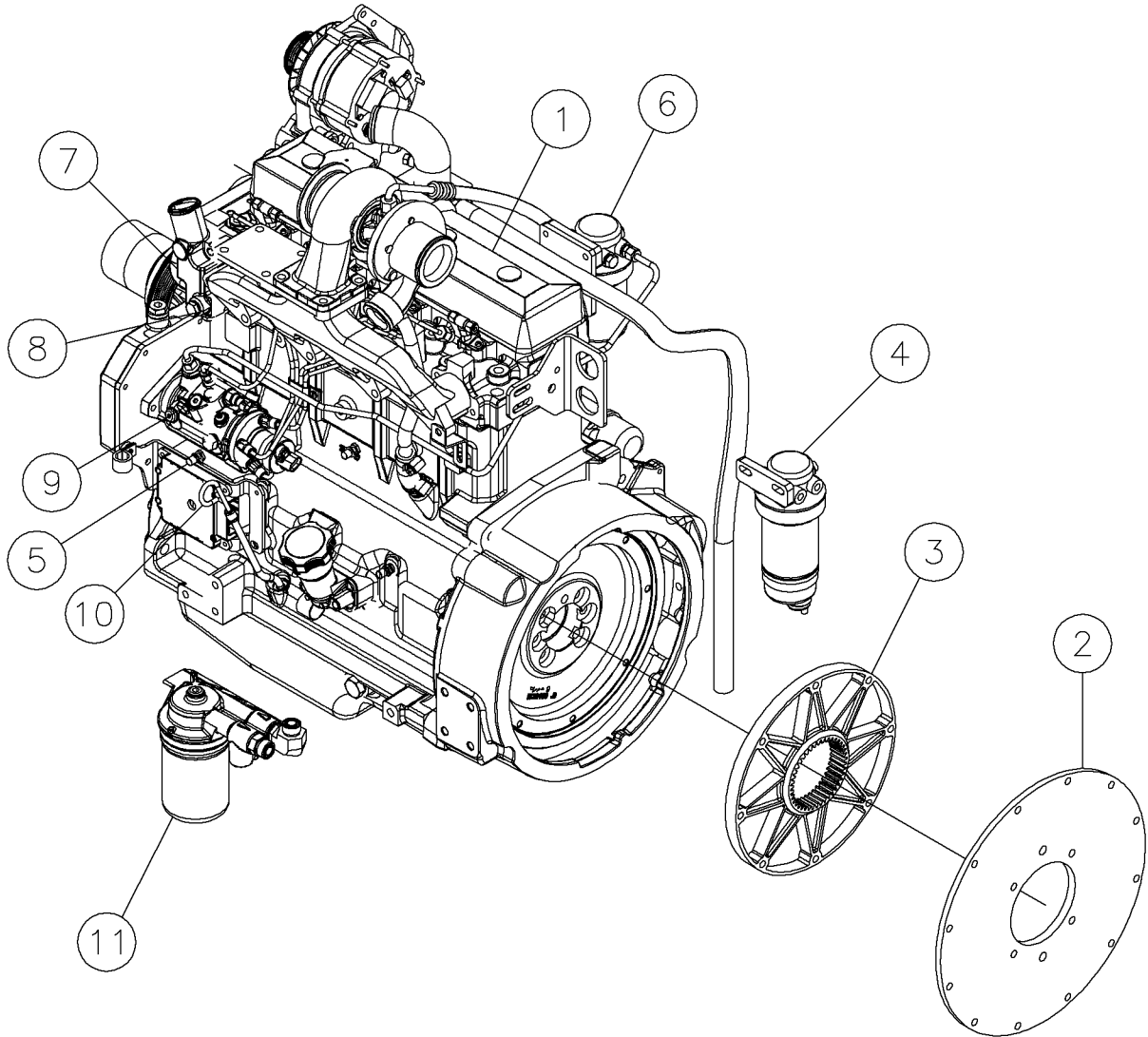



## Components-Engine Fig 5-1z01

REF. NO.	*	PART NO.	DESCRIPTION	QTY.	REMARKS
1		296269735	ENGINE-TIER III 140 HP JD 4045H	1	
2		251684001	PLATE - PUMP MOUNT	1	
3		220075001	FLANGE-65 FLE-PA 10"FLYWHEEL	1	
4		296273001	10X16 4MIL VACUUM POUCH	1	
		296272995	SEDIMENT BOWL	1	
5		180005696	SENSOR-OIL PRESSURE	1	
6		626275001	ELEMENT-SECONDARY FUEL FILTER	1	
7		180005647	THERMOSTAT	1	
8		180005687	SWITCH-TEMP	1	
9		296302386	FUEL INJECTION PUMP	1	
10		152008001	DIPSTICK	1	
11		618429001	ELEMENT-OIL FILTER (500 HRS)	1	

Components-Engine Fig 5-1z02

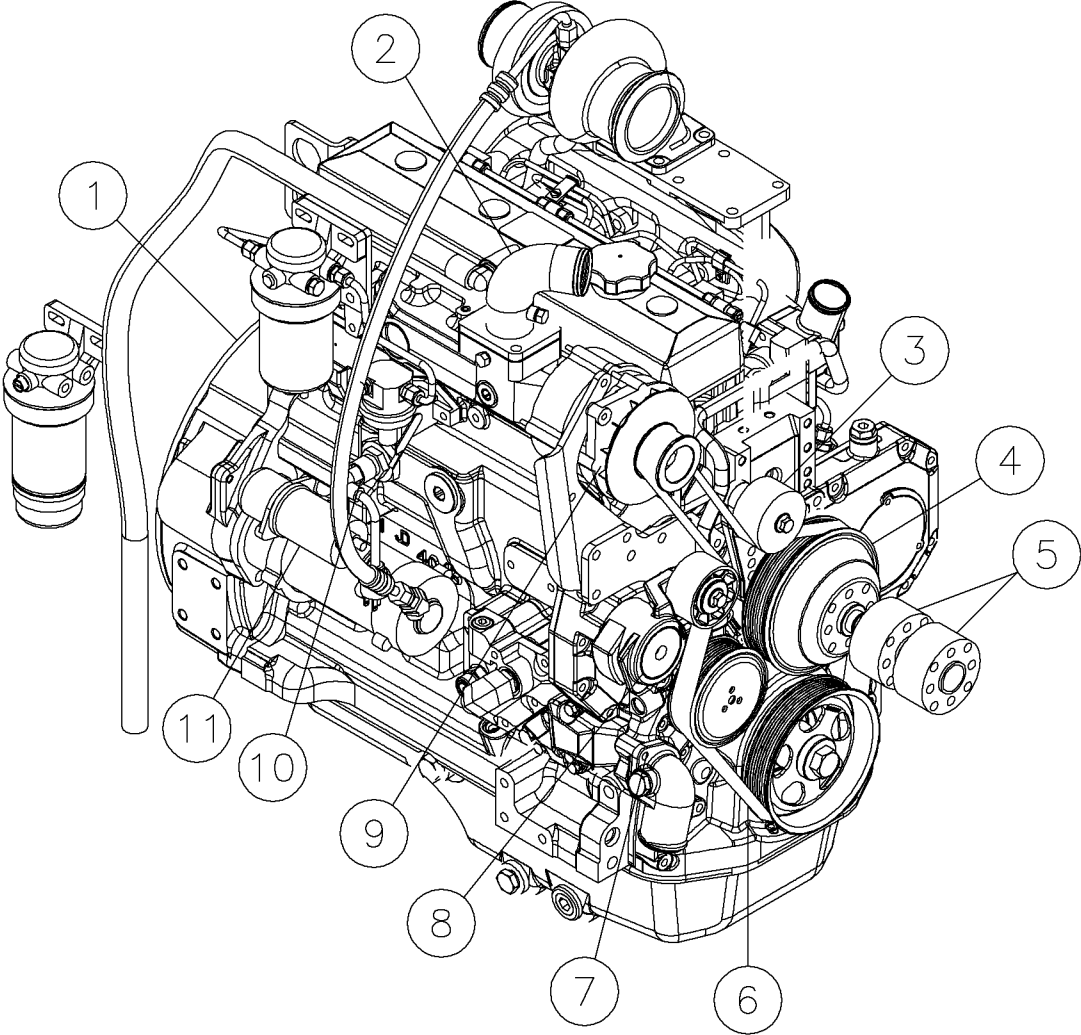

## Components-Engine Fig 5-1z02

REF. NO.	*	PART NO.	DESCRIPTION	QTY.	REMARKS
1		296269735	ENGINE-TIER III 140 HP JD 4045H	1	
2		296272989	AIR INTAKE	1	
		296251840	GASKET	1	
3		296251849	PULLEY	1	
		296302387	BUSHING	1	
		296302389	BUSHING	1	
		296302390	BOLT-HFLGHCS-10.9 M10X1.50X65	1	
4		131959047	SHEAVE	1	
5		280971001	SPACER - 1 3/4" ENGINE FAN	2	
6		296302388	V-BELT	1	
7		180005697	PUMP-WATER	1	
		601720001	GASKET-WATER PUMP	1	
8		296278205	SHEAVE-BELT TENSIONER	1	
9		180011694	ALTERNATOR	1	
10		296278209	FUEL FILTER PRESSURE SENSOR	1	
11		903384003	MOTOR-STARTING	1	

Cooler Shroud Fig 5-2

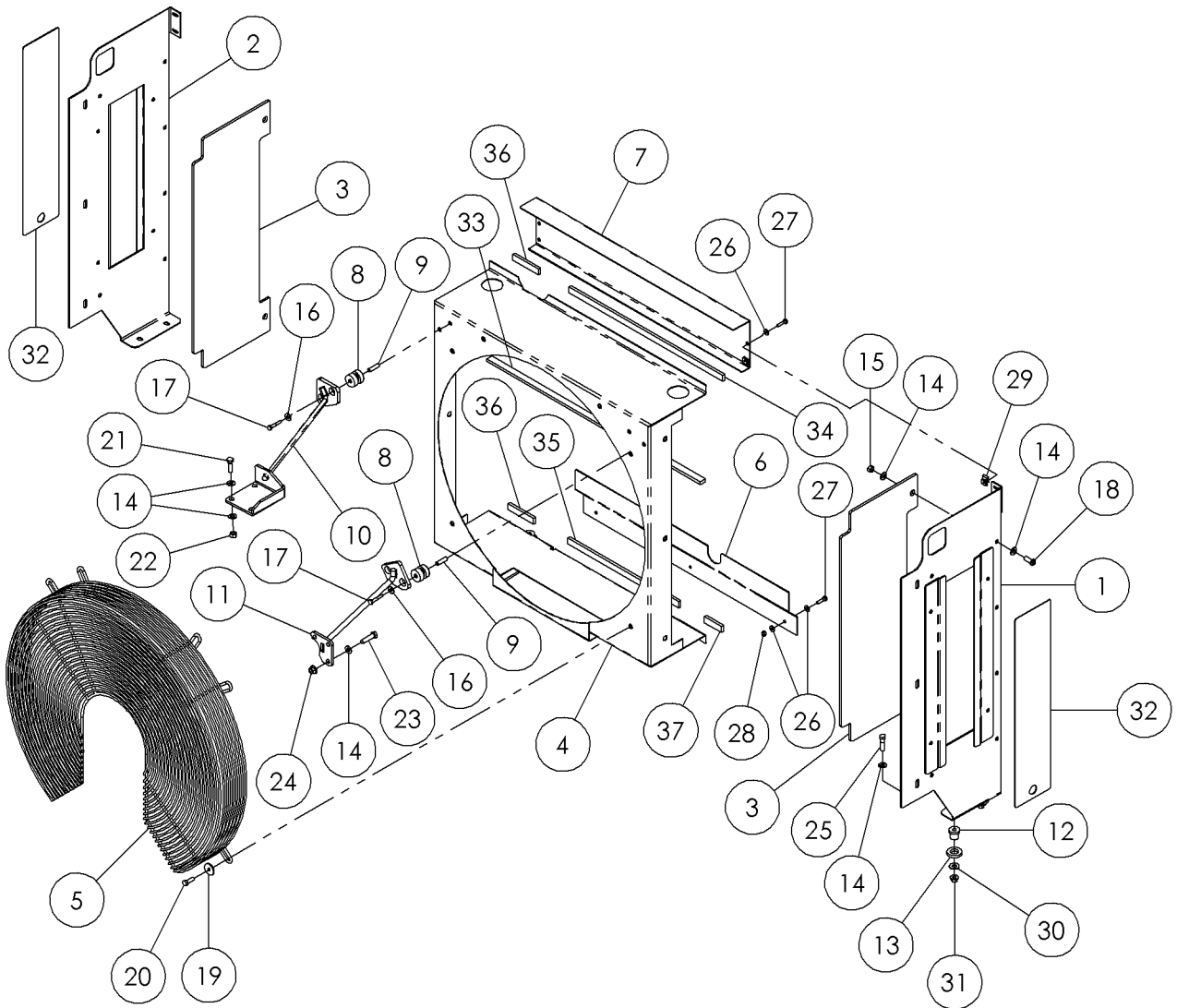

Illustration No. 296280909

## Cooler Shroud Fig 5-2

REF. NO.	*	PART NO.	DESCRIPTION	QTY.	REMARKS
1		296292032	WELDMENT - RH RADIATOR	1	
2		296292036	WELDMENT - LH RADIATOR	1	
3		296274583	FOAM- RADIATOR SIDE	2	
4		296289037	WELDMENT - SHROUD FAN	1	
5		296289024	GUARD	1	
6		296280872	PANEL - RECIRCULATION BLOCK	1	
7		296280873	PANEL - RECIRCULATION BLOCK	1	
8		294553001	MOUNT-UPPER RADIATOR ISOLATOR	4	
9		291550001	SPACER-RADIATOR ISOLATOR	4	
10		296300479	BRACKET-LH RADIATOR	1	
11		296274631	STRUT - RH RADIATOR	1	
12		294552001	MOUNT-LOWER RADIATOR ISOLATOR	4	
13		291549001	SPACER-LOWER ISOLATOR	4	
14		235713001	WASHER-FLATSTRL-.38-.41X.81-.06-YA-A325	39	
15		250508001	NUT - 3/8-NC Gr8 TOP LOCK Y/ZINC	8	
16		485003	WASHER-1/4 FLAT	4	
17		238210001	BOLT - 1/4-20X1 1/2 GR8 HEX ZYC	4	
18		103978010	BOLT-3/8NCX1 BUT.HD.SOCKET	18	
19		287758001	WASHER - VAC SYSTEM	6	
20		238209001	BOLT-5/16-18X1 GR8 HEX ZINC YC	6	
21		235736001	BOLT-3/8-16X1 1/4 ZYC	3	
22		235725001	NUT - HEX - .38 - 16 - GR8 - YZ	3	
23		508476040	SCREW-HCS,M10-1.50X40,10.9,YZ,ISO4017,FT	3	
24		506986010	NUT-HEXFLNG,M10-1.50,CL10,YZ,ISO4161	3	
25		235723001	SCREW - HCS -.38 - 16 X 1.50 - GR8 - YZ	4	
26		252251001	WASHER-1/4 SAE FLAT ZP	10	
27		235735001	BOLT-1/4-20X1 GR8 HEX ZYC	7	
28		235732001	NUT - HEX - .25 - 20 - GR8 - YZ	3	
29		5549001	NUT-U-CLIP 1/4 NC	4	
30		485007	WASHER-FLATSTD-.38-.44X1.00-.08-CZ	4	
31		4536001	NUT - 3/8-16 FLG. WHIZ LOCK	4	
32		296292031	CLEANOUT COVER - RADIATOR	2	
33		296292037	WEATHERSTRIP - 30 IN	1	
34		296292038	WEATHERSTRIP - 21.6 IN	1	
35		296292039	WEATHERSTRIP - 15.6 IN	1	
36		296292049	WEATHERSTRIP - 3.6 IN	2	
37		296292051	WEATHERSTRIP - 2.4 IN	1	

Radiator/Charge Air Cooler Fig 5-3

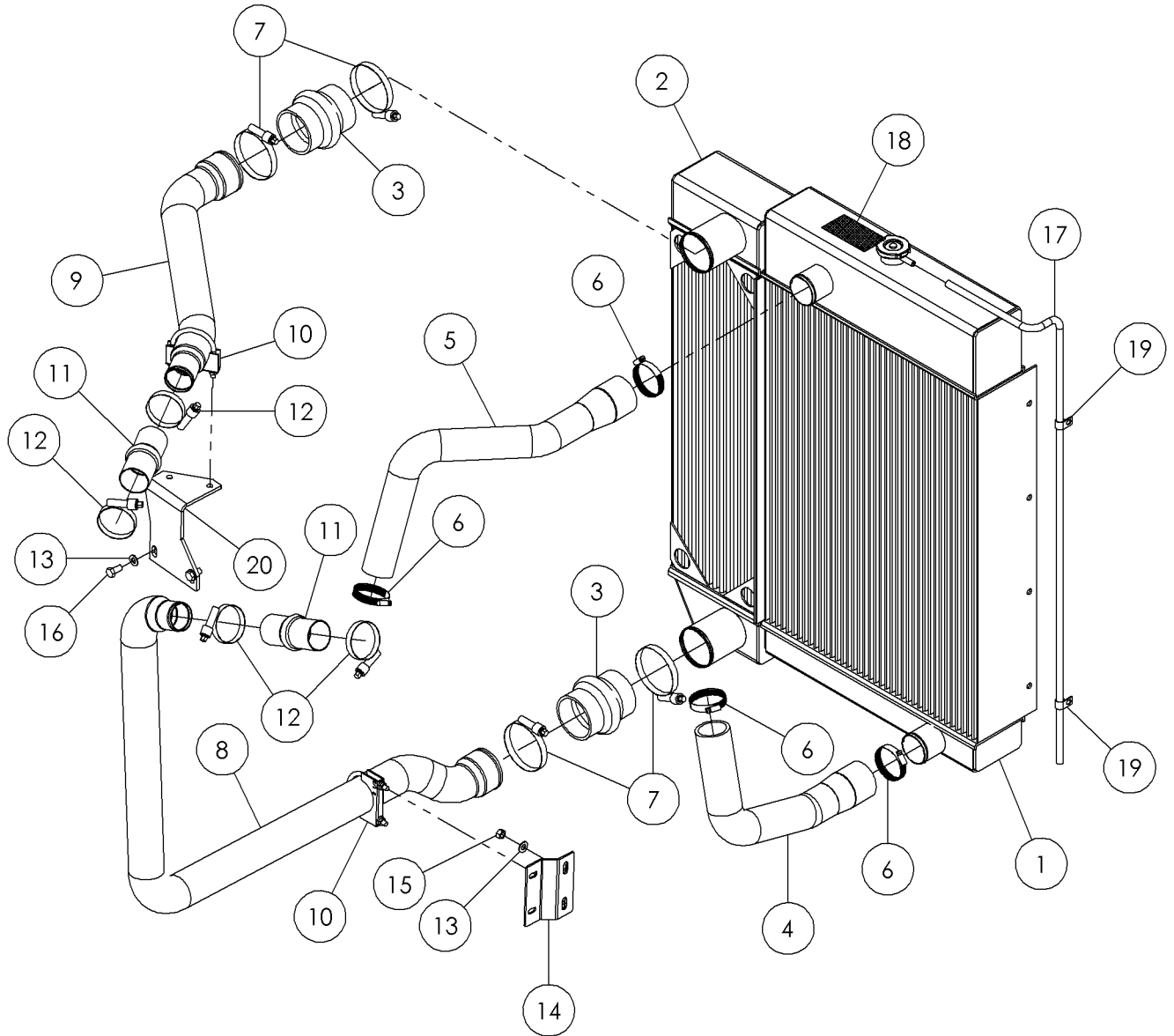
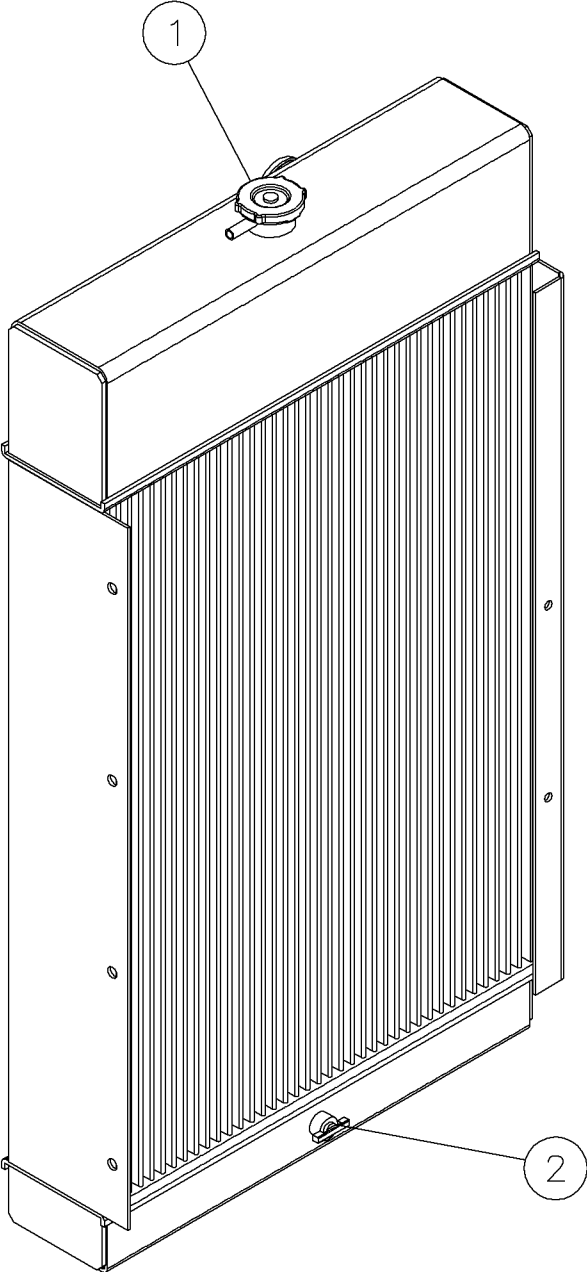

Illustration No. 296280910

## Radiator/Charge Air Cooler Fig 5-3

REF. NO.	*	PART NO.	DESCRIPTION	QTY.	REMARKS
1		296279966	COOLER - RADIATOR	1	Breakdown Fig. 5-3z01
2		296279965	COOLER - AIR	1	
3		617884001	HOSE- HUMP CAC 3.00 X 3.00 - 4.38	2	
4		296274678	HOSE - RADIATOR LOWER	1	
5		296274677	HOSE - RADIATOR UPPER	1	
6		1580013	HOSE CLAMP - 2 1/2"	4	
7		113095001	HOSE CLAMP-CONST.TRQ. CT350L	4	
8		296274680	TUBE - CHARGE AIR LOWER	1	
9		296274679	TUBE - CHARGE AIR UPPER	1	
10		2609007	MUFFLER CLAMP-2 1/2"	2	
11		280917001	CONNECTOR - CAC HUMP HOSE	2	
12		116769001	CLAMP - CON TORQUE 1 3/4 - 2 5/8	4	
13		235713001	WASHER-FLATSTRL-.38-.41X.81-.06-YA-A325	4	
14		296274587	BRACKET - LOWER CAC	1	
15		250508001	NUT - 3/8-NC Gr8 TOP LOCK Y/ZINC	2	
16		508476020	SCREW-HCS,M10-1.50X20,10.9,YZ,ISO4017,FT	2	
17		296284053	HOSE - ANTIFREEZE OVERFLOW 5/16 X 50"	1	
18		2326315	DECAL-WARNING	1	Domestic
		2326I315	DECAL-WARNING	1	International
19		279015001	HOSE CLAMP - 9/16 W/13/32 HOLE	2	
20		296299329	BRACKET - UPPER CAC	1	

Components-Radiator Fig 5-3z01





## Components-Radiator Fig 5-3z01

REF. NO.	*	PART NO.	DESCRIPTION	QTY.	REMARKS
1		296302410	RADIATOR CAP	1	
2		296302411	DRAIN COCK	1	

Air Cleaner Fig 5-4

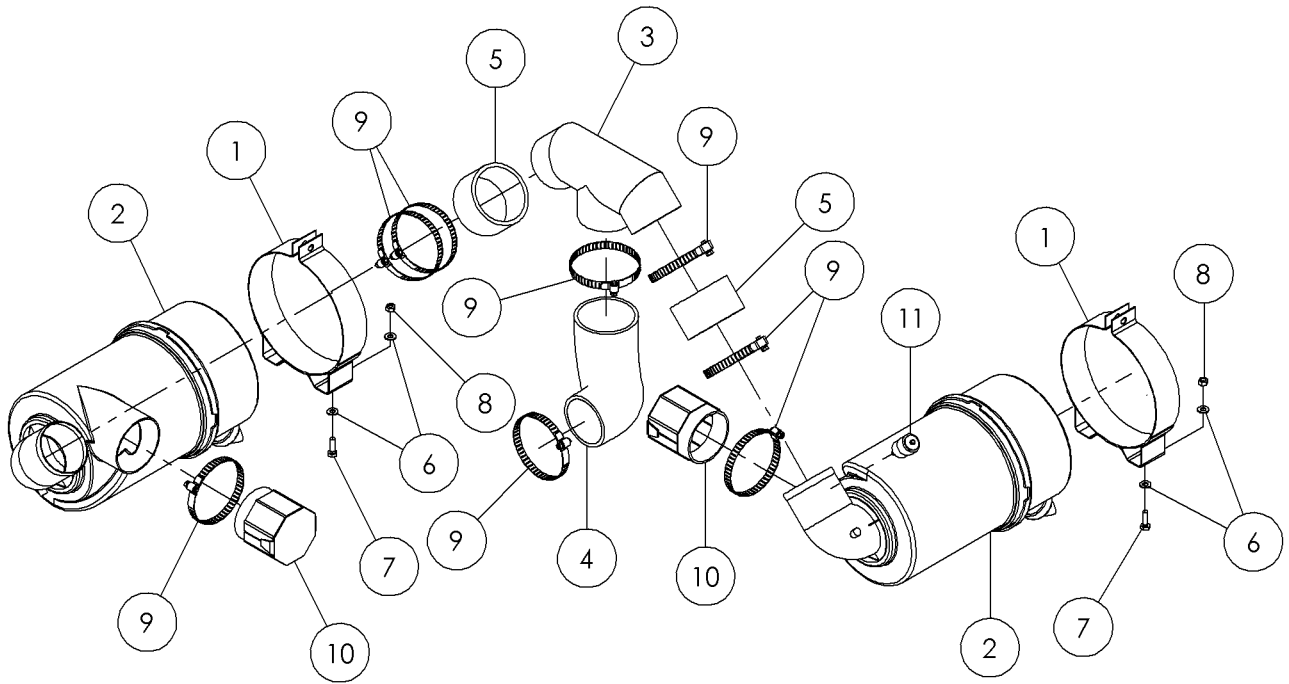
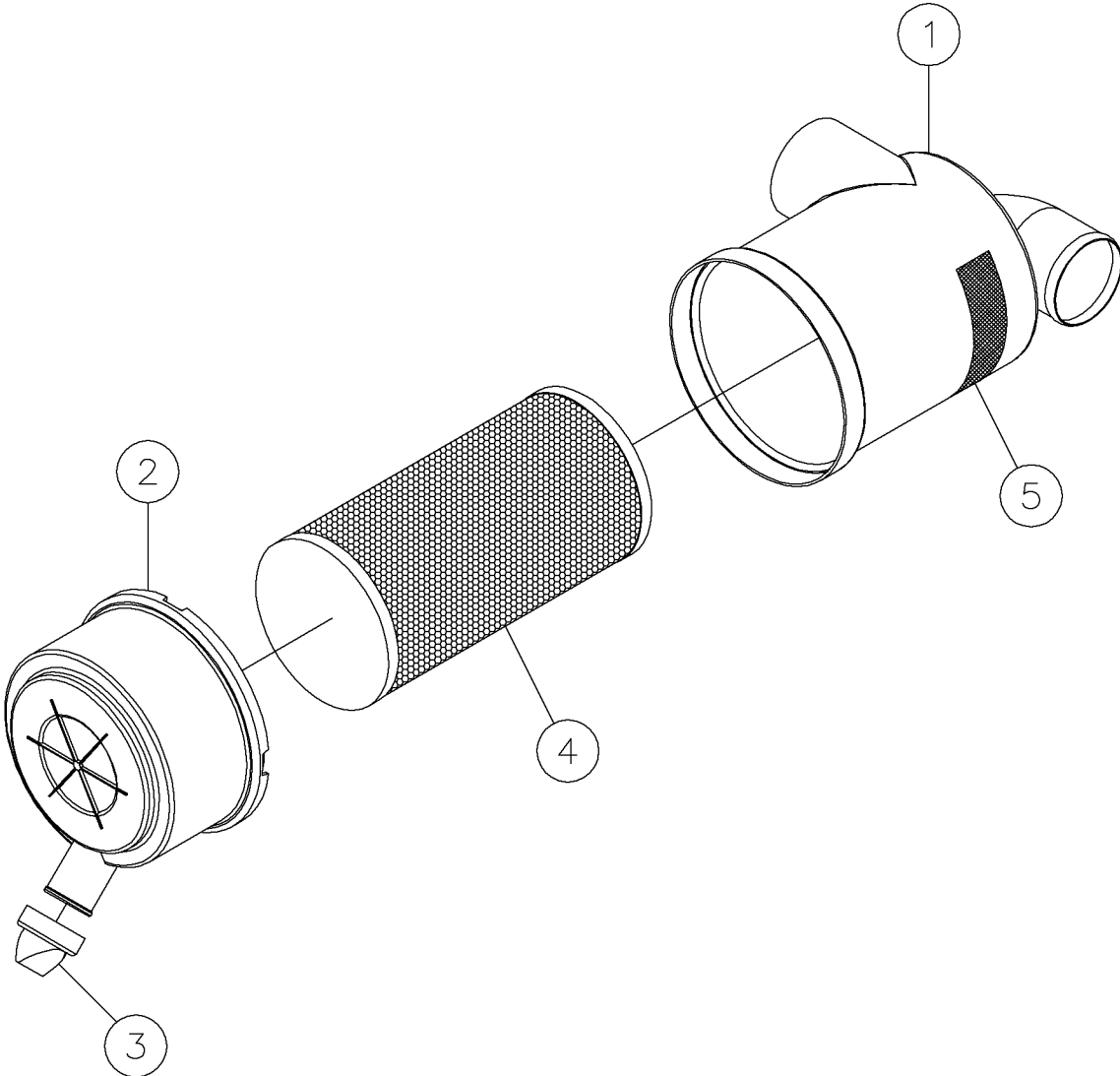

Illustration No. 296279876

## Air Cleaner Fig 5-4

REF. NO.	*	PART NO.	DESCRIPTION	QTY.	REMARKS
1		220167001	CLAMP-AIR CLEANER H00-2023	2	
2		224847001	AIR CLEANER	2	Breakdown Fig. 5-4z01
3		296280371	WELDMENT - MANIFOLD - INTAKE AIR	1	
4		296274693	HOSE- 3.5" -3 XCX INLET AIR	1	
5		296274582	HOSE - 3.5" CONNECTOR	2	
6		235714001	WASHER - FLATSTRL - .31 - .34 X .69 - .06-YZ-A325	8	
7		238209001	BOLT-5/16-18X1 GR8 HEX ZINC YC	4	
8		235741001	NUT - HEX - .31 - 18 - GR8 -YZ	4	
9		1580019	HOSE CLAMP - 4 1/2"	8	
10		296277941	COVER - INLET AIR	2	
11		2164001	INDICATOR - RAX00-2351	1	

Components-Air Cleaner Fig 5-4z01



## Components-Air Cleaner Fig 5-4z01

REF. NO.	*	PART NO.	DESCRIPTION	QTY.	REMARKS
1		224847003	BODY ASSEMBLY	1	
2		220166007	COVER ASSEMBLY	1	
3		220166009	VALVE	1	
4		220166005	ELEMENT ASSEMBLY	1	
5		224847005	DECAL - INSTRUCTION	1	
		224847001	AIR CLEANER	1	Includes All Items In Figure
note			There are two air cleaners. The quantities listed are only for one.		

Exhaust Fig 5-5

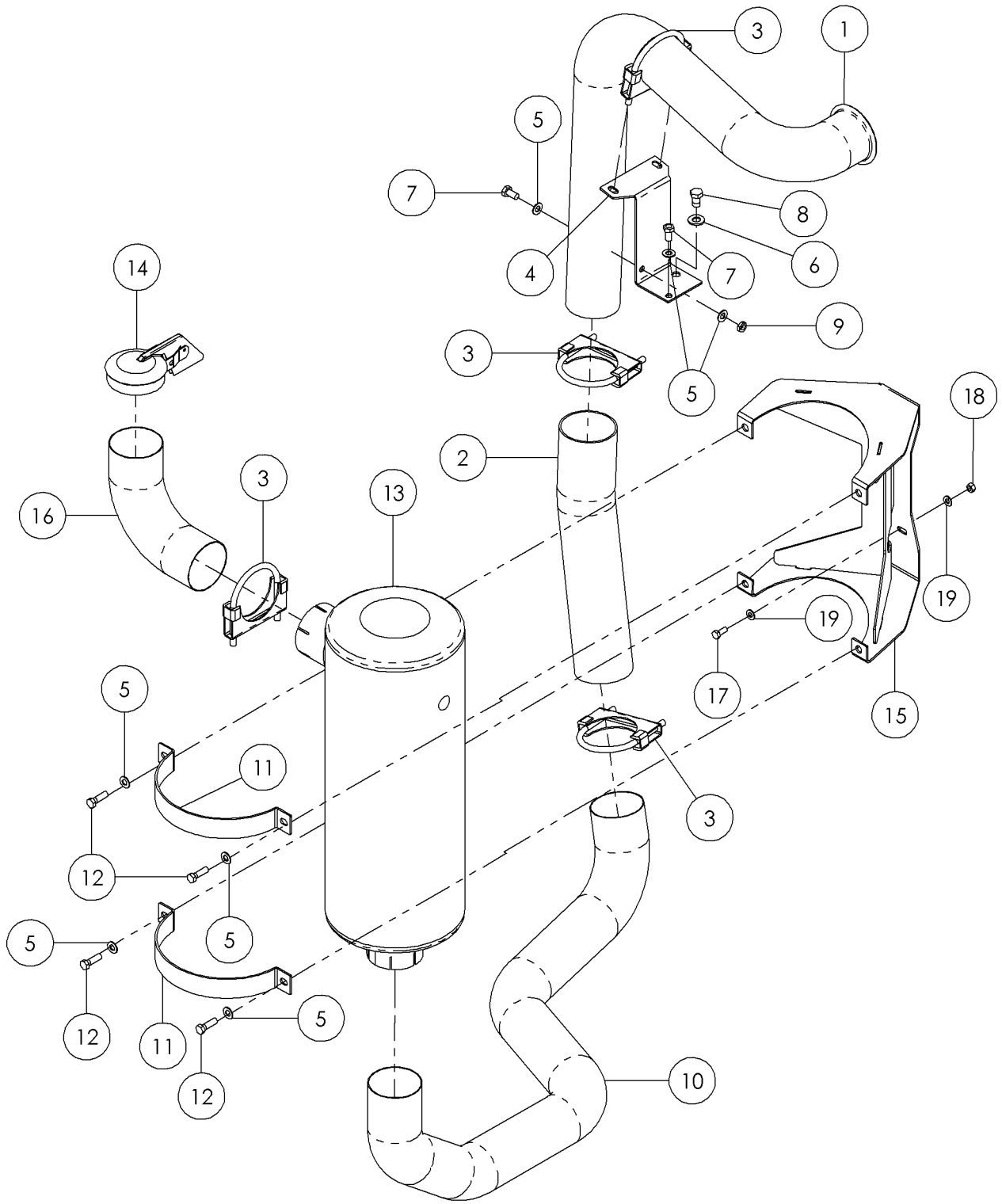

Illustration No. 296279877

## Exhaust Fig 5-5

REF. NO.	*	PART NO.	DESCRIPTION	QTY.	REMARKS
1		296274687	TUBE- 3.5" EXHAUST	1	
2		296274722	TUBE - 3.5" X 18" FLEX EXHAUST	1	
3		2609013	CLAMP-MUFFLER 3 1/2	5	
4		296307437	BRACKET - EXHAUST	1	
5		235713001	WASHER-FLATSTRL-.38-.41X.81-.06-YA-A325	7	
6		485025	WASHER-1/2 FLAT-HARDENED-YZ	1	
7		508476020	SCREW-HCS,M10-1.50X20,10.9,YZ,ISO4017,FT	2	
8		507407020	SCREW-HCS,M12-1.75X20,10.9,YZ,ISO4017,FT	1	
9		61656001	NUT-HEX M10-1.50 CL8 YZ D934	1	
10		296279822	TUBE - LOWER EXHAUST WRAPPED	1	
11		296274676	STRAP - MUFFLER CLAMP	2	
12		235736001	BOLT-3/8-16X1 1/4 ZYC	4	
13		296280907	MUFFLER - 3.5" SIDE OUTLET	1	
14		287964001	CAP-RAIN	1	
15		296280764	BRACKET ASSY-MUFFLER SUPPORT	1	
16		296280908	ELBOW - 90 DEG 3.5"	1	
17		235742001	BOLT-5/16-18X3/4 GR8 ZYC	2	
18		240333001	NUT-5/16-18 GR8 TL ZINC PLTD	2	
19		235714001	WASHER-FLATSTRL-.31-.34X.69-.06-YZ-A325	4	

Fuel & Antifreeze Tank Fig 5-6

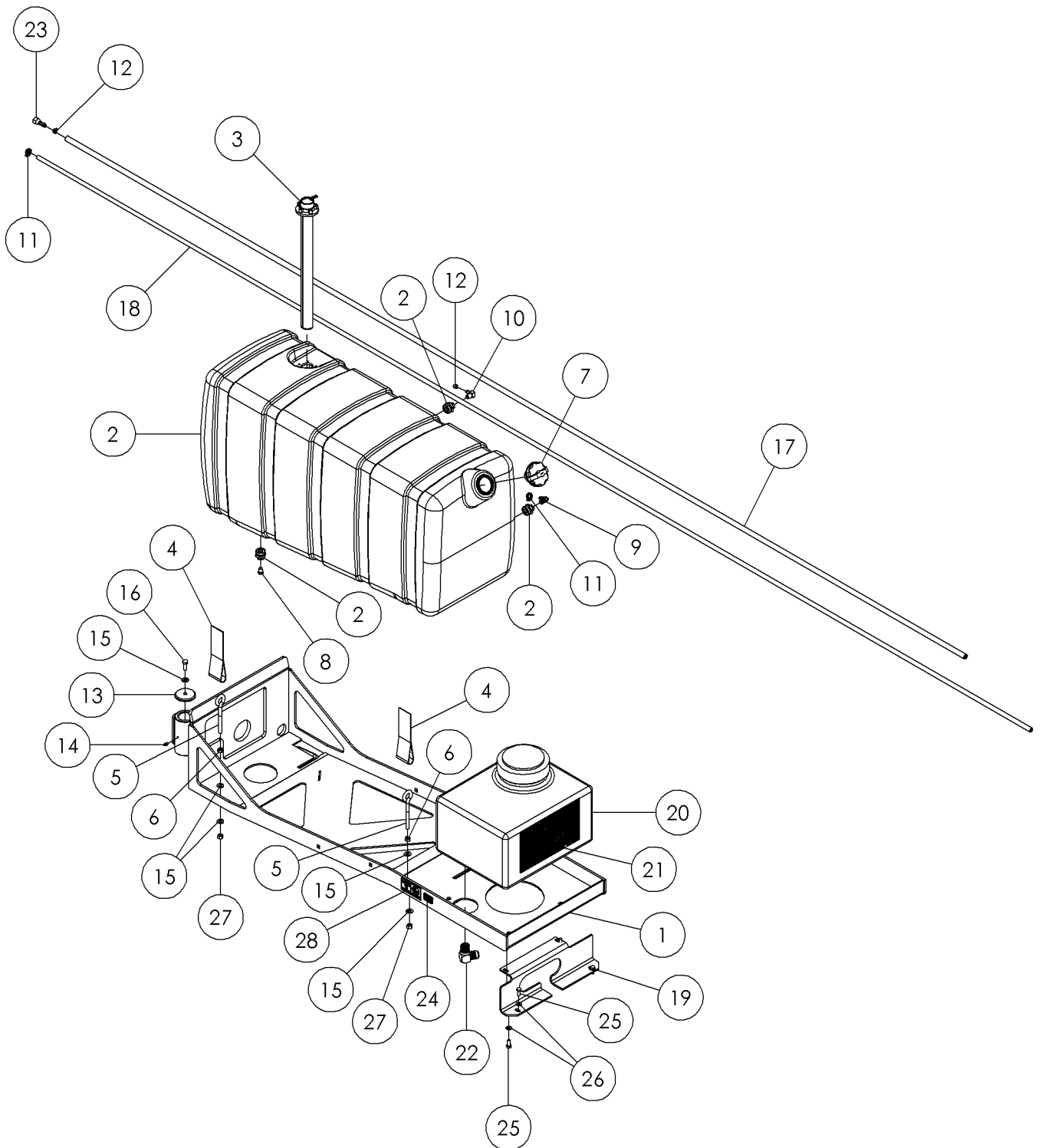

Illustration No. 296279878



## Fuel &amp; Antifreeze Tank Fig 5-6

REF. NO.	*	PART NO.	DESCRIPTION	QTY.	REMARKS
1		296280773	MOUNT ASSY - PIVOTING FUEL TANK	1	
2		289602001	FUEL TANK	1	
3		292038001	SENDER - FUEL LEVEL	1	
4		287698001	STRAP - FUEL TANK	2	
5		279374001	BOLT - 3/8-16 X 5 1/2 EYE	2	
6		235725001	NUT - HEX - .38 - 16 - GR8 - YZ	2	
7		279326001	CAP - DIESEL FUEL W/LOCK	1	
8		282126001	FITTING - 1/4 BRASS HEX PLUG	1	
9		602037001	FITTING -1/4 PIPE 5/16 BARB 90	1	
10		603184001	FITT.-3/8 BARBX1/4M NPT 90DEG	1	
11		1578001	HOSE CLAMP - 1/4"	2	
12		1580001	HOSE CLAMP - 3/8"	2	
13		285625001	PLATE - COMB HOLD DOWN WSH.	1	
14		598001	FITTING-1/4" NF ST GREASE ZERK	1	
15		235713001	WASHER-FLATSTRL-.38-.41X.81-.06-YA-A325	5	
16		235727001	SCREW-HCS-.38-16X1.00-GR8-YZ	1	
17		296280221	HOSE - FUEL SUPPLY 3/8" X 152"	1	
18		296277783	HOSE - FUEL RETURN 5/16 X 168"	1	
19		296280978	SUPPORT - FUEL TANK	1	
20		236466001	TANK-6 GALLON POLY	1	
21		70000675	DECAL-NAVIGATOR FREEZE GUARD	1	
22		56215001	FITTING-3/4M PIPE-#12M JIC 90	1	
23		296280466	FITTING-5FS JIC X 6 HOSE BARB-ST	1	
24		70000098	DECAL-DIESEL (AT/UND)	1	Domestic
24		70001098	DECAL-DIESEL FUEL	1	International
25		235742001	BOLT-5/16-18X3/4 GR8 ZYC	4	
26		235714001	WASHER-FLATSTRL-.31-.34X.69-.06-YZ-A325	4	
27		250508001	NUT - 3/8-NC Gr8 TOP LOCK Y/ZINC	2	
28		2326324	DECAL-WARNING/REFUEL	1	Domestic
28		23261324	DECAL - WARNING EXPLOSION	1	International

Hood Fig 5-7

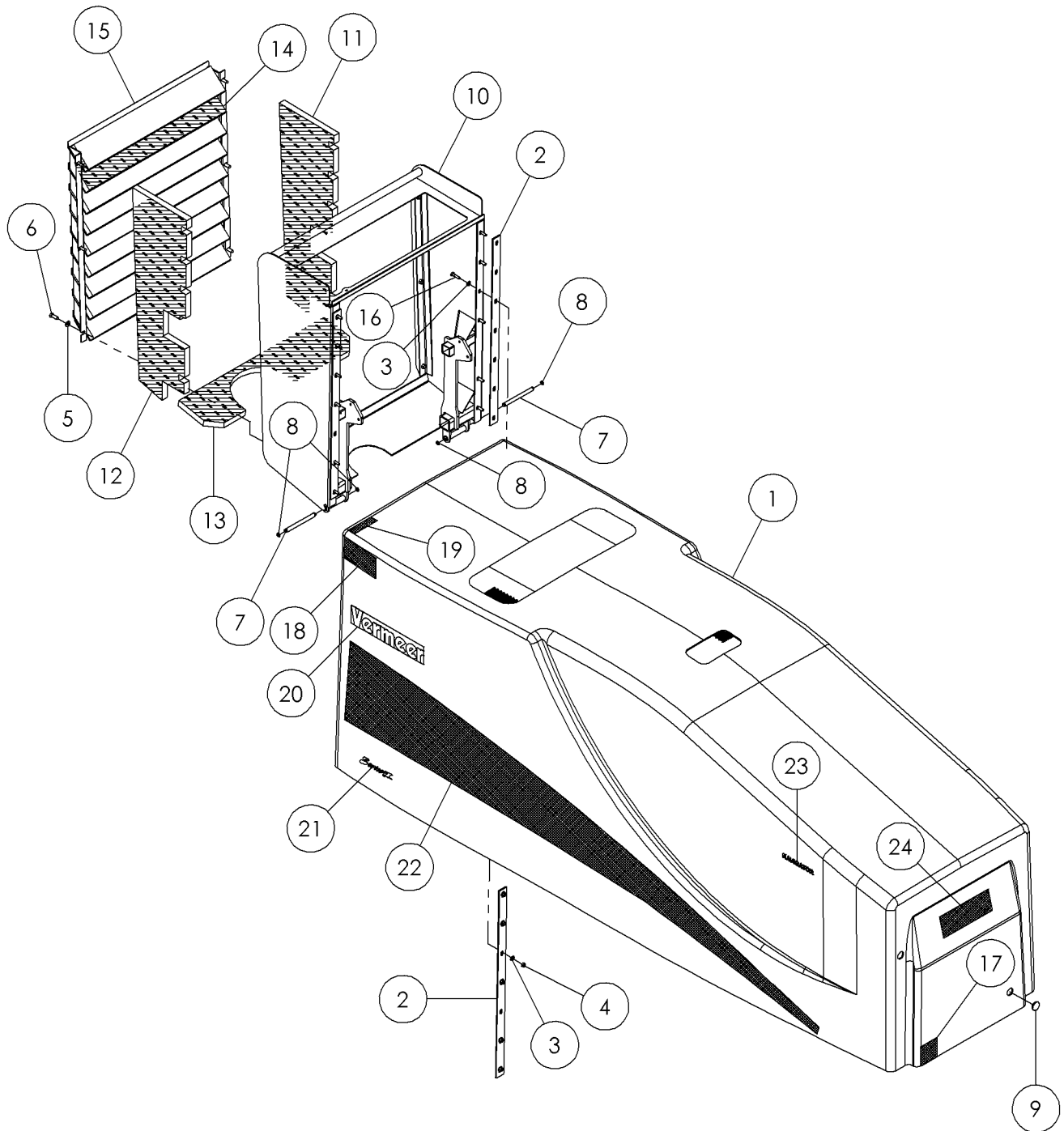

Illustration No. 296279872

## Hood Fig 5-7

REF. NO.	*	PART NO.	DESCRIPTION	QTY.	REMARKS
1		296280983	HOOD ASSEMBLY - ENGINE COVER	1	Braekdown Fig. 5-7z01
2		278829001	BAR - GRILLE MOUNT	4	
3		235714001	WASHER-FLATSTRL-.31-.34X.69-.06-YZ-A325	24	
4		235741001	NUT - HEX - .31 - 18 - GR8 -YZ	12	
5		235713001	WASHER-FLATSTRL-.38-.41X.81-.06-YA-A325	6	
6		235727001	SCREW-HCS-.38-16X1.00-GR8-YZ	6	
7		291616001	PIN - 1/2" X 5.75	2	
8		294761001	SNAP RING - .50 SHR-50	4	
9		296280859	PLUG - 1.125"	1	
10		296277849	FRAME - HOOD PIVOT	1	
11		296277871	FOAM- ACOUSTICAL RACK SIDE GRILL	1	
12		296277872	FOAM- ACOUSTICAL OPERATOR SIDE GRILL	1	
13		296277873	FOAM- ACOUSTICAL LOWER GRILL	1	
14		296277867	FOAM - ACOUSTIC GRILL	9	
15		296277894	GRILL - RADIATOR DISCHARGE	1	
16		248031001	BOLT-5/16-18X1 1/4 GR8 ZYC	12	
17		7000B119	DECAL - PATENT INDUSTRIAL	1	
18		7000A576	DECAL-DANGER	1	Domestic
18		700IA576	DECAL-DANGER	1	International
19		7000B388	DECAL - HOOD LATCH	1	
20		2326619	DECAL- VERMEER 3 X 15	1	
21		7000C463	DECAL - SERIES II MEDIUM	1	
22		7000D176	DECAL D36X50II STRIPE	1	
23		70000614	DECAL-MODEL NAVIGATOR (BIG)	1	
24		7000B812	DECAL - WARNING	1	Domestic
24		700IB812	DECAL - WARNING	1	International

Hood Latch Fig 5-8

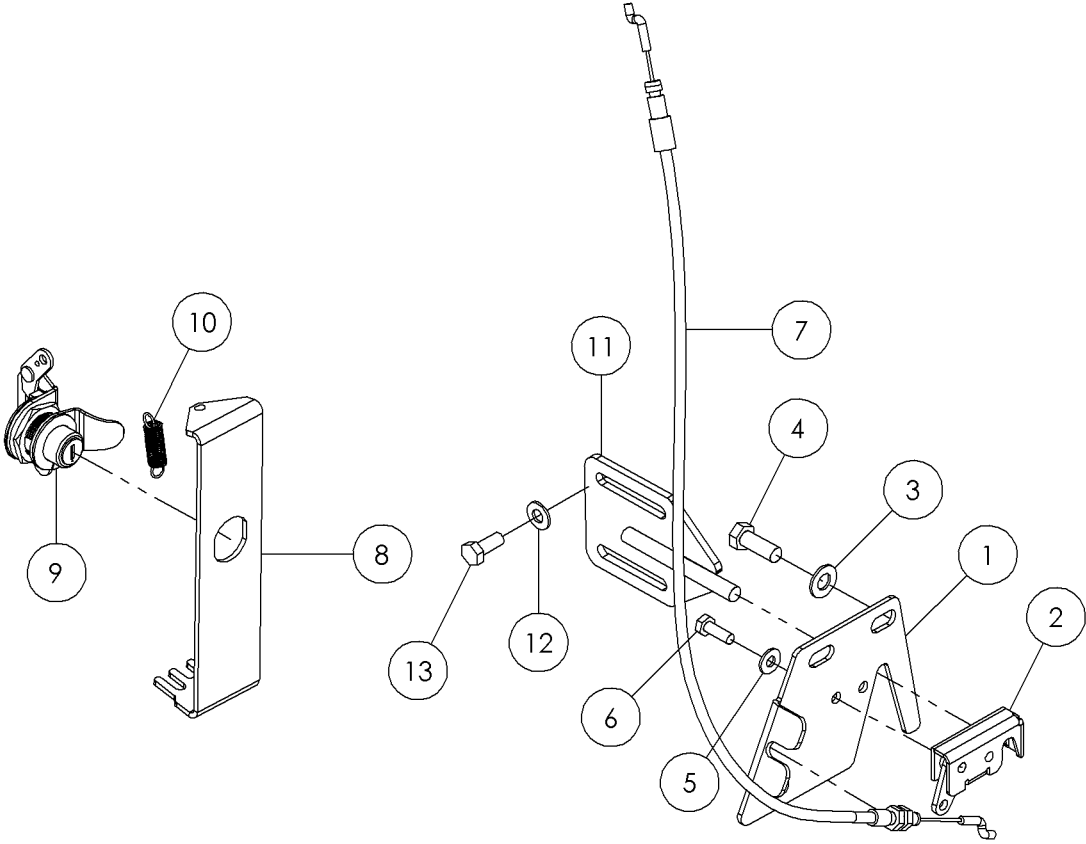

Illustration No. 296279873

## Hood Latch Fig 5-8

REF. NO.	*	PART NO.	DESCRIPTION	QTY.	REMARKS
1		296280434	BRACKET - CABLE END	1	
2		159973001	LATCH - MINI ROTARY, RIGHT	1	
		161562001	KEY-LATCH	1	
3		235713001	WASHER-FLATSTRL-.38-.41X.81-.06-YA-A325	3	
4		235727001	SCREW-HCS-.38-16X1.00-GR8-YZ	3	
5		235716001	WASHER-FLATSTRL-.25-.28 X .63 - .06 - CZ	2	
6		235734001	BOLT-1/4-20X3/4 GR8 ZYC	2	
7		159972001	CABLE - HOOD RELEASE	1	
8		296279848	BRACKET - HOOD CABLE	1	
9		155985001	LATCH - PUSHBUTTON	1	
10		282052001	SPRING -2084 EXTENSION 1.50"	1	
11		296279837	STRIKER - ADJUSTABLE	1	
12		235714001	WASHER-FLATSTRL-.31-.34X.69-.06-YZ-A325	3	
13		235742001	BOLT-5/16-18X3/4 GR8 ZYC	3	

Hood Pivot Fig 5-9

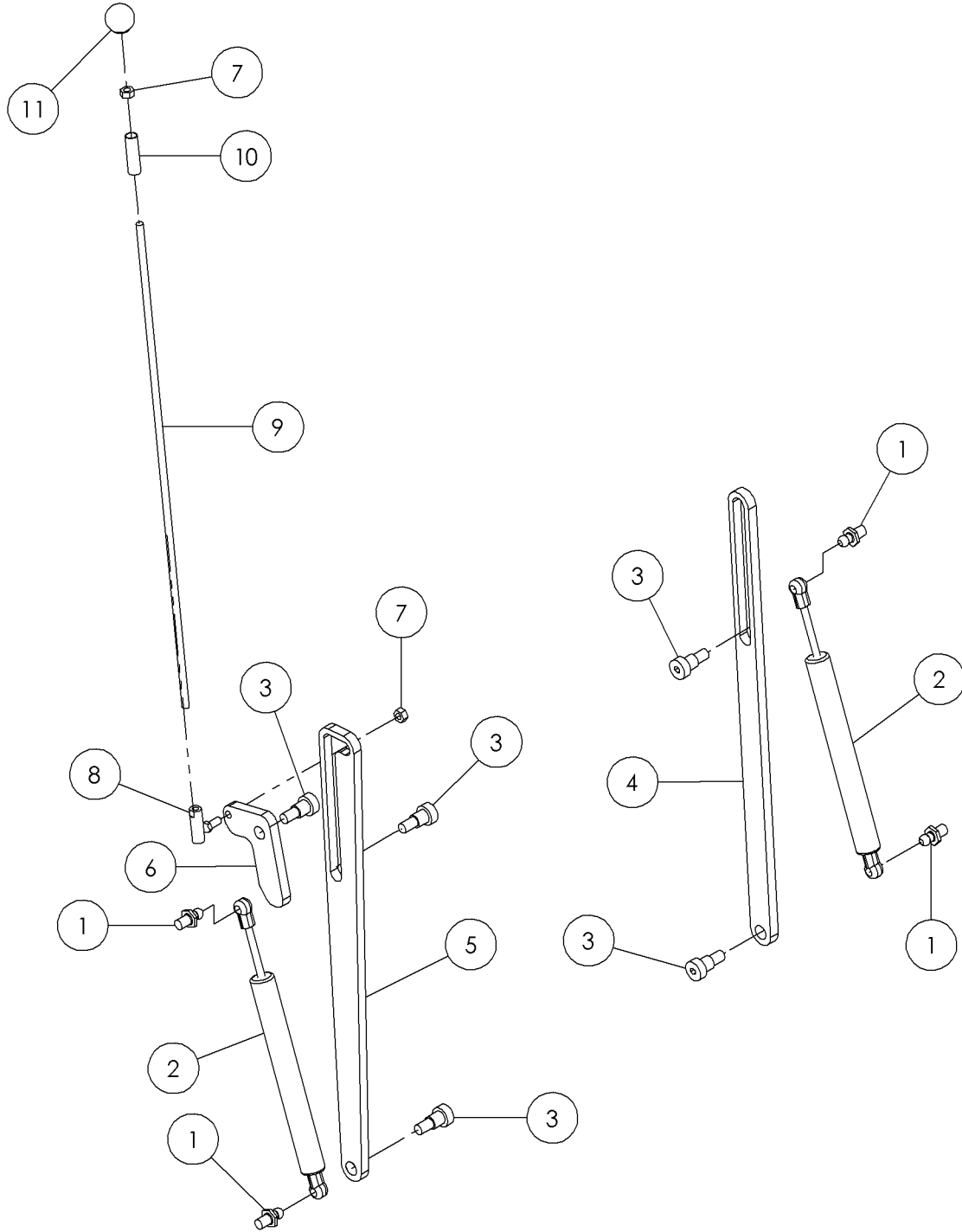
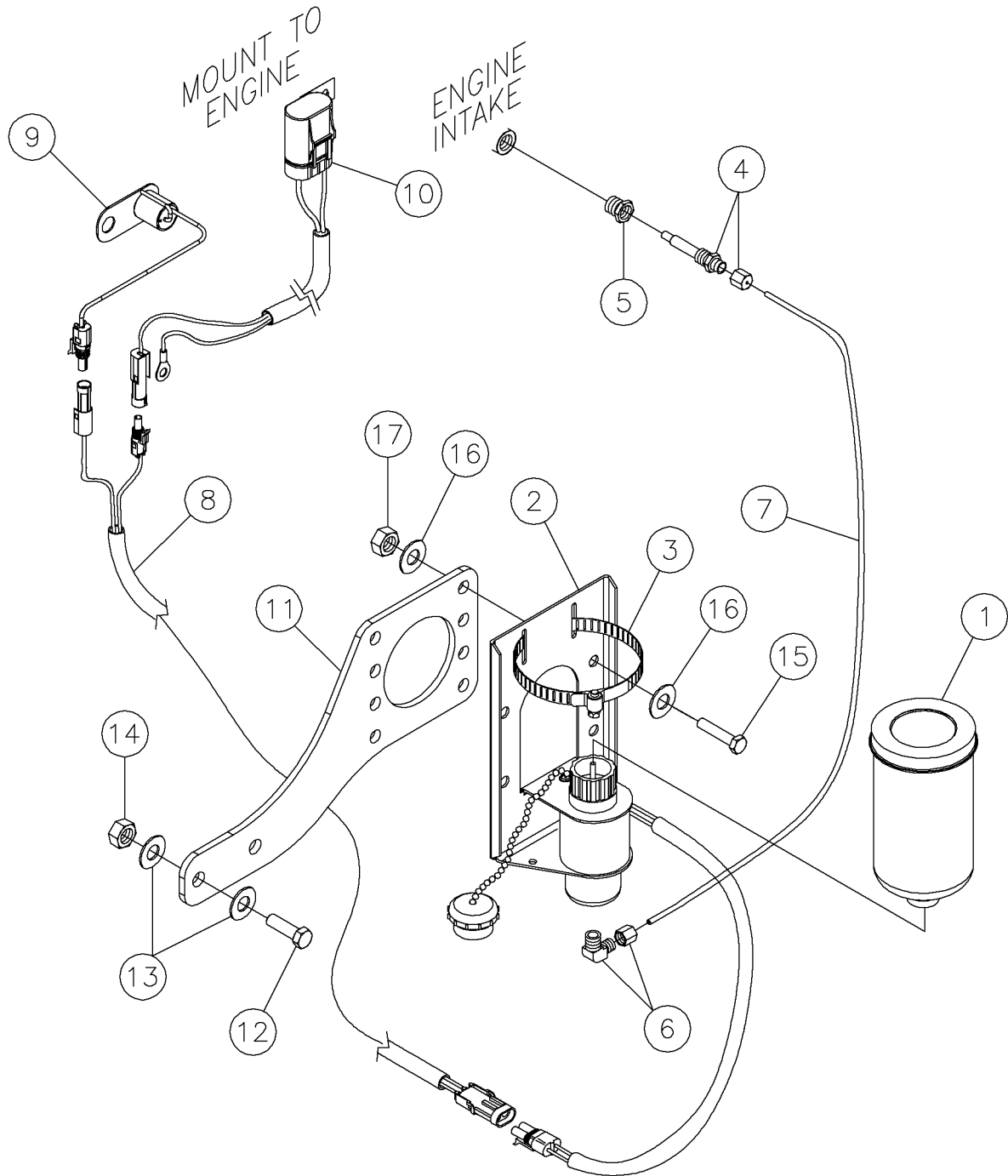

Illustration No. 29629874

## Hood Pivot Fig 5-9

REF. NO.	*	PART NO.	DESCRIPTION	QTY.	REMARKS
1		285784001	BALL - STUD	4	
2		251144001	SPRING - GAS ASSIST	2	
3		240056001	SCREW-SHSS-.50X.50-.38-16THD-CZ	5	
4		296274624	SLIDE - HOOD CATCH	1	
5		296274625	SLIDE - HOOD LOCK	1	
6		296274628	PIVOT -UNLATCH	1	
7		4734001	NUT-1/4-28 NF HEX	2	
8		1489001	BALL JOINT - 1/4" SP1002 CP	1	
9		296274629	ROD - HOOD LATCH	1	
10		1803089	SPRING-COMP.#30 3/8ODX5/16ID.	1	
11		296292050	KNOB- 1" ROUND	1	

Ether Start System (Optional) Fig 5-10





## Ether Start System (Optional) Fig 5-10

REF. NO.	*	PART NO.	DESCRIPTION	QTY.	REMARKS
1		296279823	CYLINDER - 8 OZ ETHER 3" DIA X 6" TALL	1	
2		296281251	ETHER 12V SOLENOID VALVE	1	
3		1580015	HOSE CLAMP - 3"	1	
4		296281253	NOZZLE ASSEMBLY	1	
5		296281252	ADAPTER	1	
6		296281254	BLOCK OR FITTING ASSEMBLY	1	
7		202831001	TUBING-NYLON 1/8OD	A/R	
8			WIRE HARNESS	1	Not Sold Separately
9		296281255	SWITCH-ENGINE TEMP SENSOR	1	
10			FUSE BLOCK HARNESS	1	Not Sold Separately
11		296277798	BRACKET - ETHER MOUNT	1	
12		235736001	BOLT-3/8-16X1 1/4 ZINC PLTD	2	
13		235713001	WASHER - FLATSTRL - .38 - .41 X .81 - .06-YA-A325	4	
14		235725001	NUT - HEX - .38 - 16 - GR8 - YZ	4	
15		279376001	BOLT - 5/16-18X1 1/2 GR8 HEX ZNC PLT	4	
16		235714001	WASHER - FLATSTRL - .31 - .34 X .69 - .06-YZ-A325	8	
17		235741001	NUT - HEX - .31 - 18 - GR8 - YZ	4	
		296277799	KIT - DEERE ETHER PARTS		

Oil Tank Fig 6-1

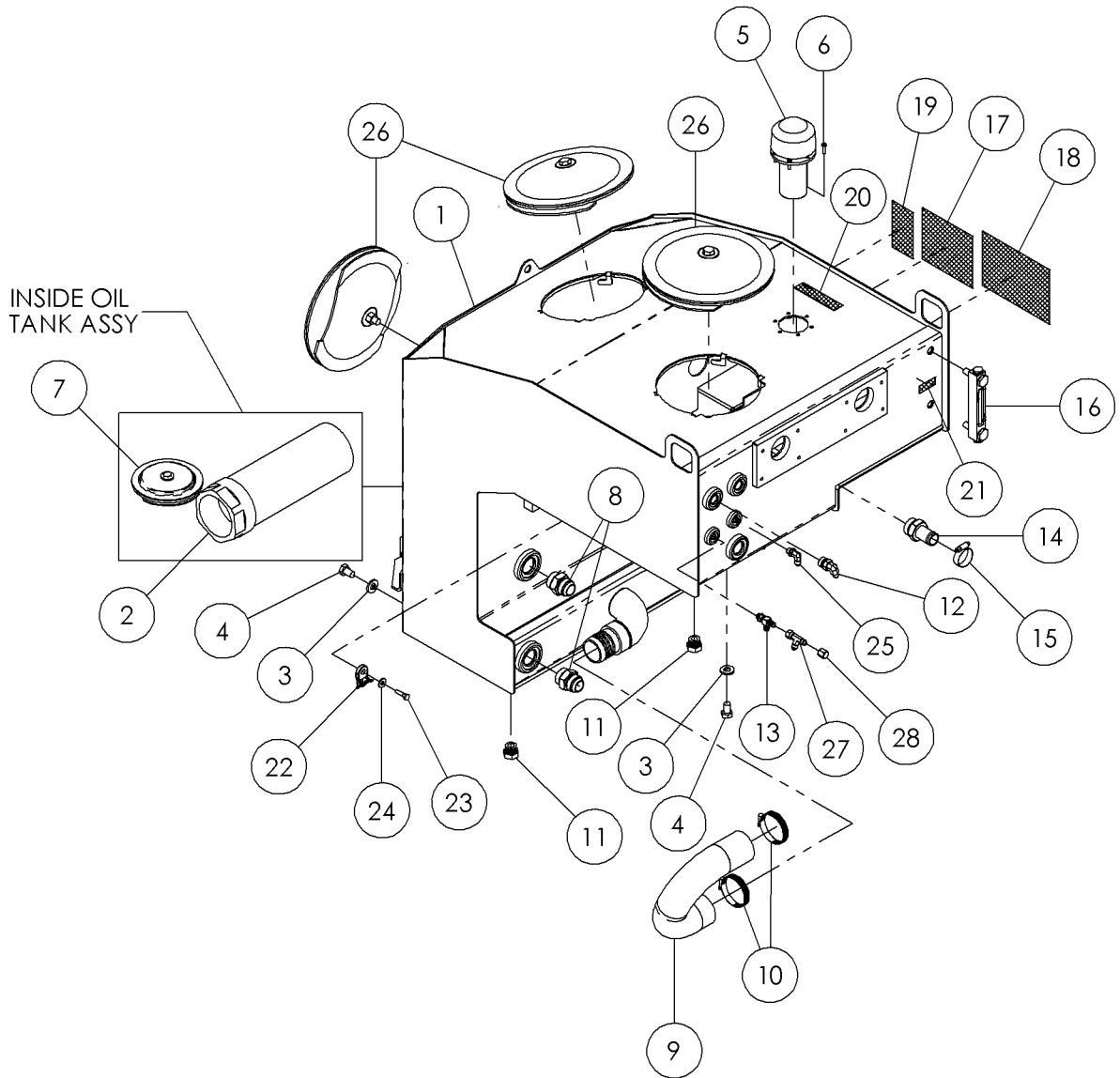

## Oil Tank Fig 6-1

REF. NO.	*	PART NO.	DESCRIPTION	QTY.	REMARKS
1		296289224	TANK - 55 GALLON OIL	1	
2		98681001	FILTER-TANK 3 NPT OUTLET PORT	1	
3		127362001	WASHER-1/2 HARD.FLAT/PLATED	6	
4		235728001	BOLT-1/2-13X3/4 GR8 ZYC	6	
5		235808001	CAP-FILLER/BREATHER W/O RELIEF	1	
6		1802006	BOLT-10-24 X 3/4 RND HD STOVE	6	
7		296257231	*COVER - 6" RESERVOIR END	1	Breakdown Fig. 6-1z02
8		60907001	FITTING-16M JICX16M STR ADAPT	2	
9		251243001	HOSE - PUMP SUCTION	1	
10		1580013	HOSE CLAMP - 2 1/2"	2	
11		56218001	FITTING - PLUG - 8MORB - HEX	2	
12		86671001	FITTING-8M ORING X4M JIC 90 EL	1	
13		81342001	FITTING-RTEE-4MJ-4MORBA-4MJ	1	
14		96709001	HOSE INSERT-16MX1 BEAD STR.	1	
15		238094001	CLAMP-3/4X1 3/4 BAND W/SCREW	1	
16		81590001	GAUGE-SIGHT	1	
17		700IC700	DECAL-D36X50II GREASE CHART	1	
18		7000C451	DECAL - FLUID CAPACITIES	1	
19		7000C446	DECAL - NO WELD	1	Domestic
19		700IC446	DECAL - NO WELD	1	International
20		70000394	DECAL-VERMEER HY POWER	1	
21		2326756	DECAL-HYDRAULIC OIL	1	Domestic
21		2326I756	DECAL-HYDRAULIC FLUID	1	International
22		296276018	MOUNT HELLER MANN TITON	2	
23		235735001	BOLT-1/4-20X1 GR8 HEX ZYC	2	
24		510337603	WASHER-FLATSTD-.25-.31X.75-.07-YZ	2	
25		59423001	FIT-4M JICX4M ADJ.90 DEG.ELBOW	1	
26		296292015	COVER 10"OIL TANK	3	Breakdown Fig. 6-1z01
27		60248001	TEE-4M JICX4M JICX4FS JIC	1	
28		61664001	CAP NUT-#4 JIC	1	

Oil tank-Cover 10" Fig 6-1z01

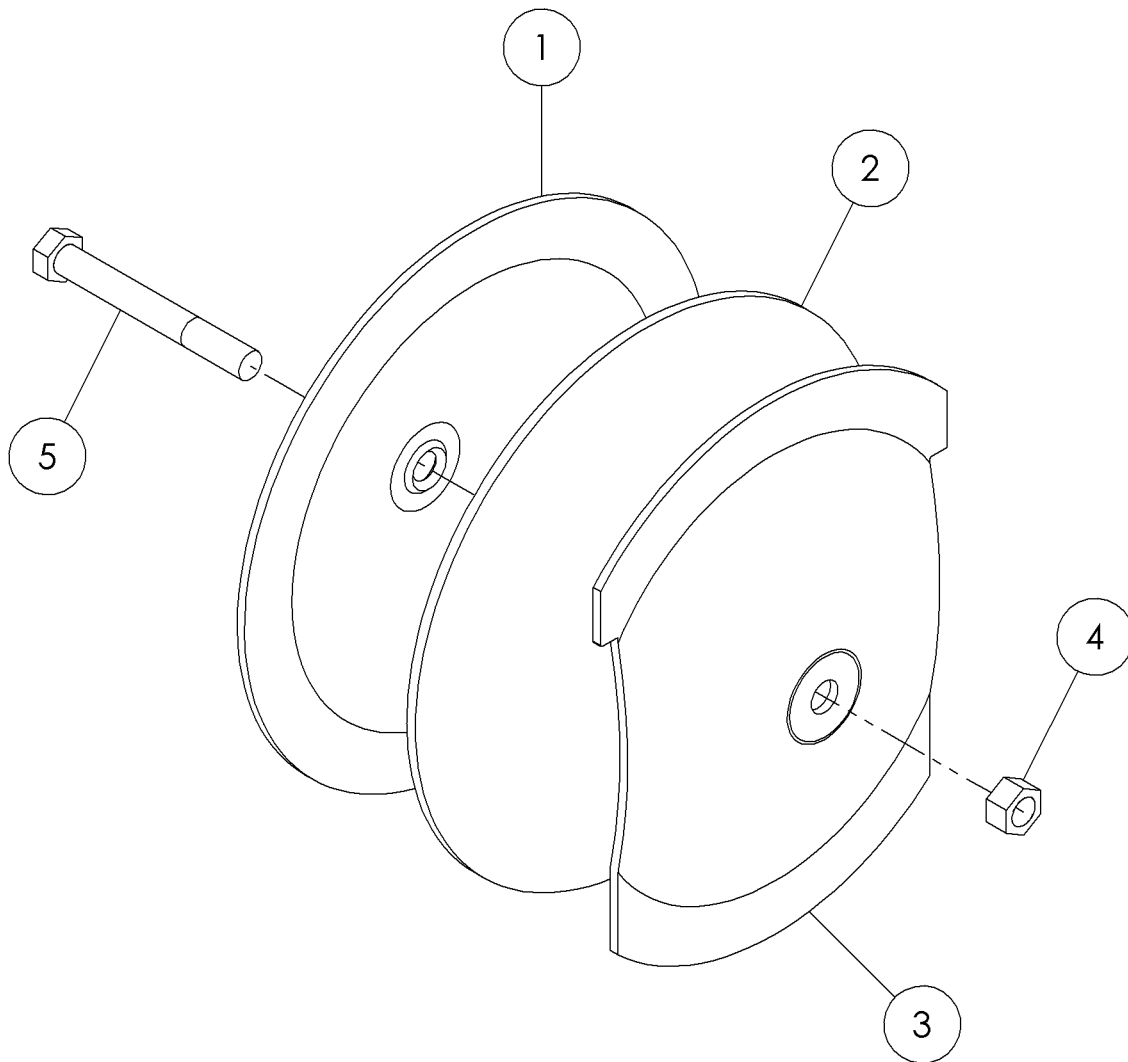

Illustration No. 296292015

## Oil tank-Cover 10" Fig 6-1z01

REF. NO.	*	PART NO.	DESCRIPTION	QTY.	REMARKS
1		296292052	10 INCH INNER COVER M	1	
2		296292053	CORK-BUNA N GASKET	1	
3		296292054	10 INCH OUTER COVER M	1	
4		235731001	NUT-1/2-13 GR8 ZYC	1	
5		238244001	BOLT 1/2"-13 X 4"GR8 HEX Y/ZIN	1	

Oil Tank-Cover 6" Fig 6-1z02

Illustration No. 296257231-1

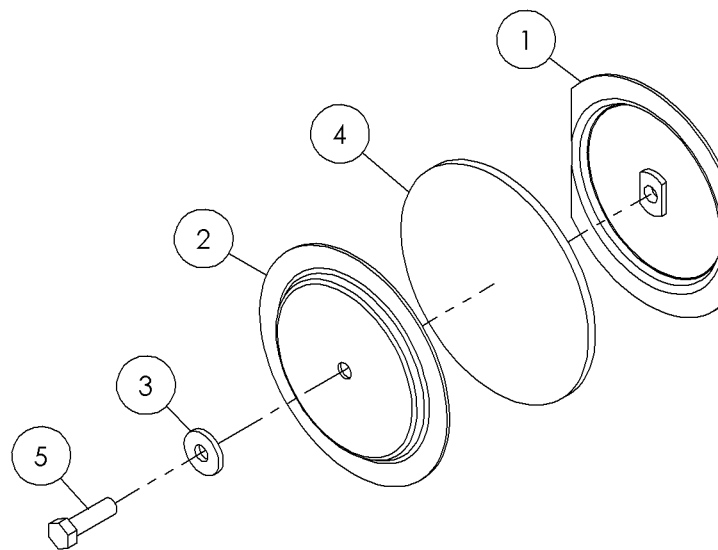

## Oil Tank-Cover 6" Fig 6-1z02

REF. NO.	*	PART NO.	DESCRIPTION	QTY.	REMARKS
1		296332273	6" CLEAN - OUT COVER BACK COVER WITH 3/8-16NC NUT	1	
2		296332275	6" CLEAN - OUT COVER FRONT COVER	1	
3		296332276	6" CLEAN - OUT COVER NYLON WASHER	1	
4		296332274	6" CLEAN - OUT COVER BUNA - N GASKET	1	
5		296332277	6" CLEAN - OUT COVER 3/8 - 16 BOLT	1	

Return Filter Manifold Fig 6-2

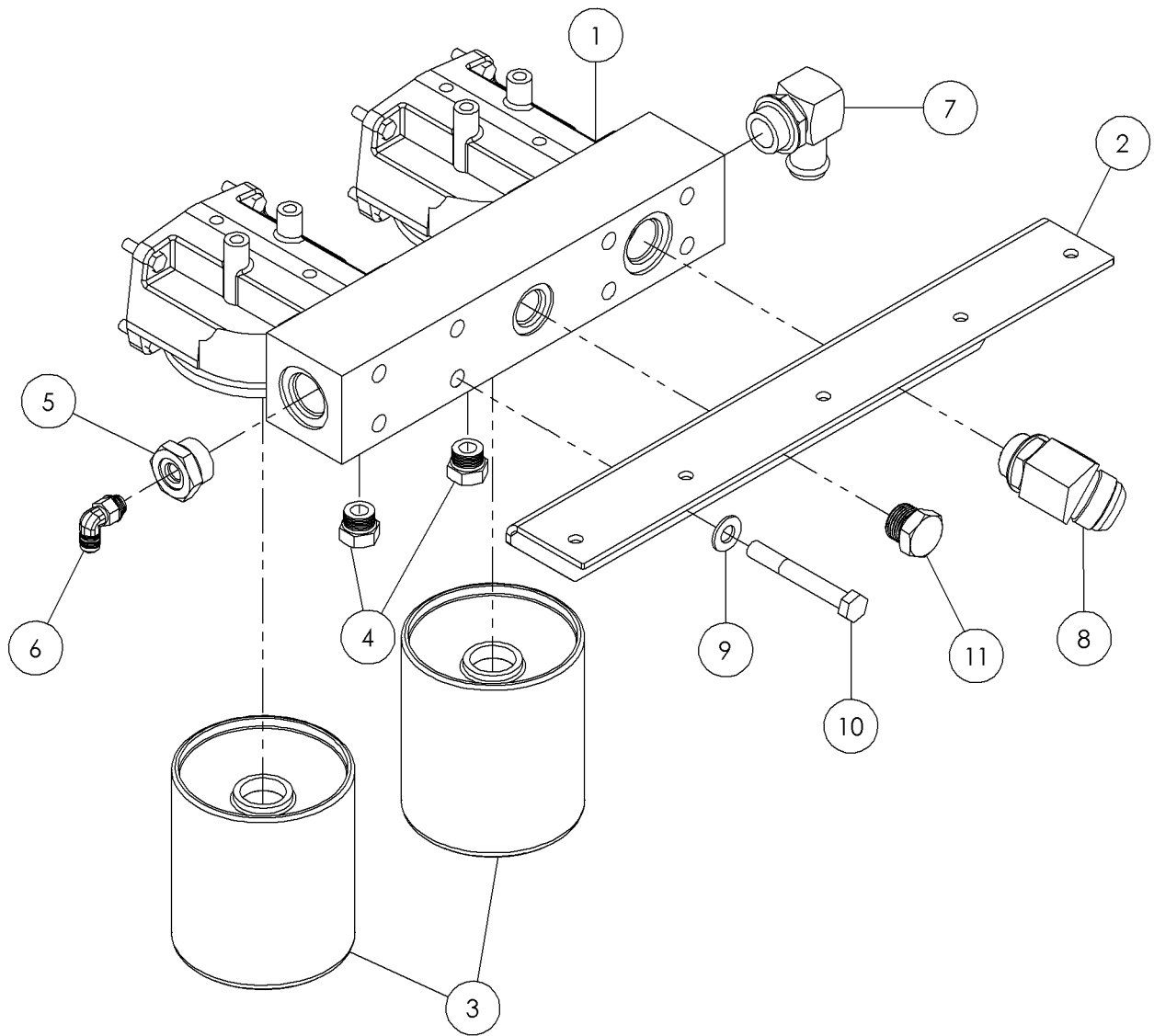

Illustration No. 296279931



Return Filter Manifold Fig 6-2

REF. NO.	*	PART NO.	DESCRIPTION	QTY.	REMARKS
1		296273660	ASSEMBLY - FILTER HEAD	1	Breakdown Fig. 6-2z01
2		296274715	SUPPORT - AIR CLEANER	1	
3		296269657	FILTER - 5 MICRON HYDRAULIC	2	
4		56218001	FITTING - PLUG - 8MORB - HEX	2	
5		279128001	FITTING - STR - 16MORB -6FORB	1	
6		59426001	FITTING - 90-6MJ-6MORBA	1	
7		100000001	FITTING-16MORINGX1"BEADED90DEG	1	
8		86234001	16M ORING X 20M JIC 45DEG.	1	
9		485025	WASHER-1/2 FLAT-HARDENED-YZ	8	
10		238213001	BOLT-1/2-13X3 3/4 GR8 HEX ZYC	8	
11		67570001	FITTING - PLUG - 12MORB - HEX	1	

Components-Filter Head Fig 6-2z01

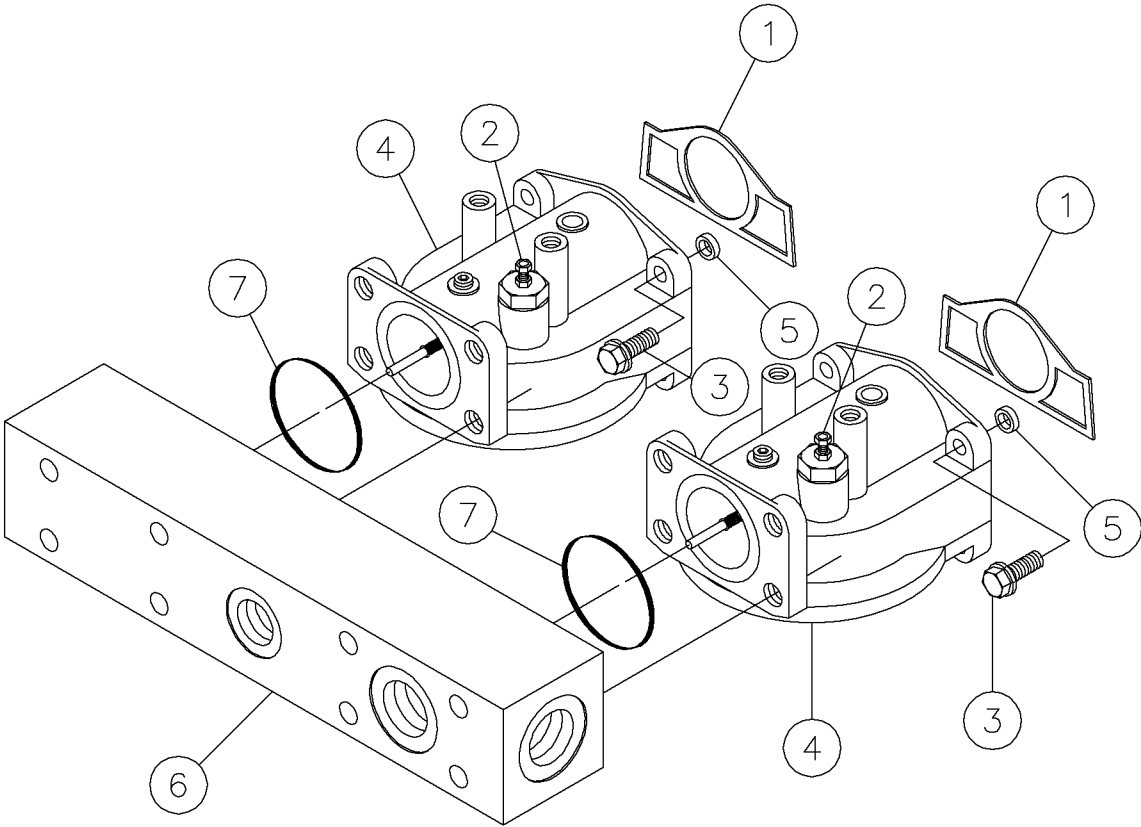

## Components-Filter Head Fig 6-2z01

REF. NO.	*	PART NO.	DESCRIPTION	QTY.	REMARKS
1		251140003	GASKET	2	
2		251140005	SWITCH - FILTER RESTRICTION	2	
3		4474010	BOLT-5/16-18X1 FLG.WHIZ PLATED	8	
4		251140001	HEAD - FILTER	2	
5		278858003	SEAL- FLANGE (FLUOROCARBON)	8	
6		251454001	BLOCK - MANIFOLD	1	
7		296302413	O RING	2	
		296273660	ASSEMBLY - FILTER HEAD		Includes All Items In Figure

Stack Pump Fig 6-3

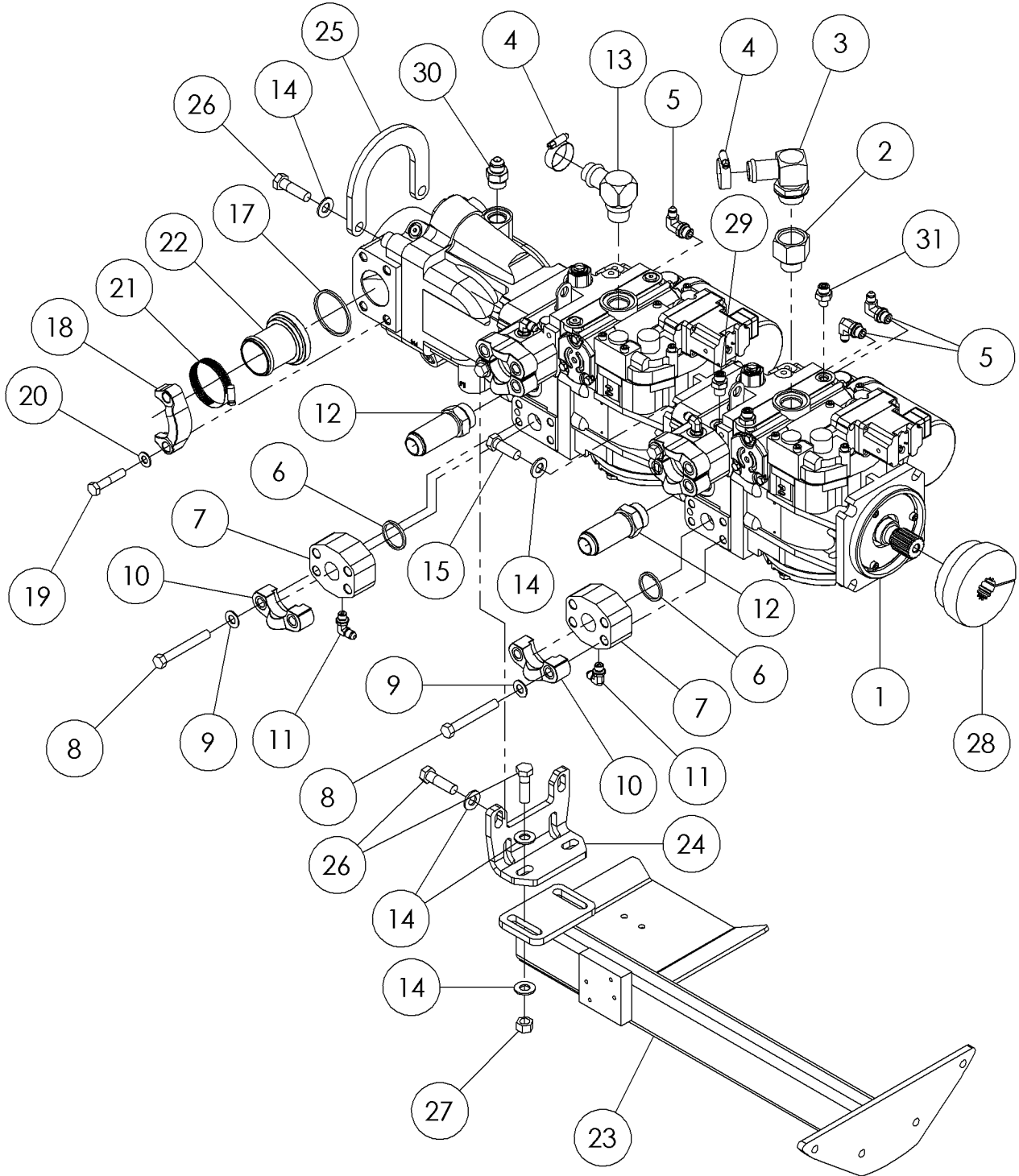
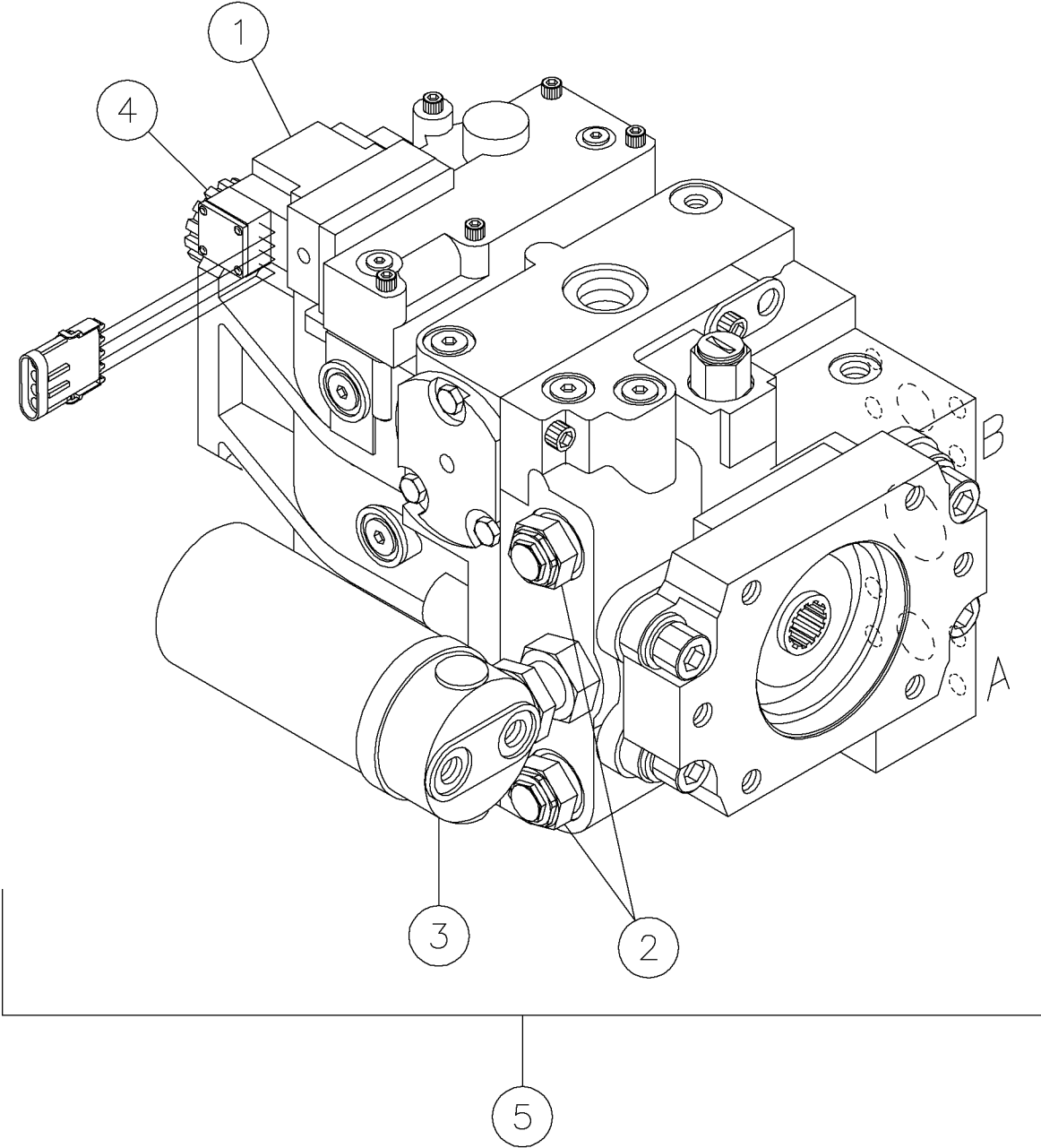

Illustration No. 296282552

## Stack Pump Fig 6-3

REF. NO.	*	PART NO.	DESCRIPTION	QTY.	REMARKS
1		278772001	PUMP ASSEMBLY	1	Breakdown Fig. 6-3z01 & 6-3z02
2		96076001	FIT.-12MX16F O-RING	1	
3		100000001	FITTING-16MORINGX1"BEADED90DEG	1	
4		238094001	CLAMP-3/4X1 3/4 BAND W/SCREW	2	
5		57950001	FITTING-90-4MJ-6MORBA	3	
6		72895001	O RING-SQ. #16 FLANGE	4	
7		296273640	FLANGE - 4 BOLT W/-4 PORT	4	
8		296273645	SCREW - HHCS - .44-14X3.25-GR8-YZ	16	
9		250515001	7/16 HARD WASHER SAE Y/ZINC	16	
10		67745001	FITTING - FLGH - 16CD62	8	
11		59423001	FIT-4M JICX4M ADJ.90 DEG.ELBOW	4	
12		94161001	FITTING-16MJICX16MORING LONG	2	
13		99706001	FITTING-12MORX1"HOSEBEAD 90DEG	1	
14		485025	WASHER-1/2 FLAT-HARDENED-YZ	12	
15		235721001	BOLT-1/2-13X1 1/2 GR8 ZINC PLT	4	
16		296273661	FITTING - 90 - 4MOR-6MJIC-100 MICRON	1	
17		72898001	O RING-SQ. #32 FLANGE	1	
18		73114001	FITTING-CODE 61 #32 FLANGE	2	
19		250574001	BOLT-10M X 50M 10.9 HEX Y/ZINC	4	
20		235713001	WASHER-FLATSTRL-.38-.41X.81-.06-YA-A325	4	
21		1580013	HOSE CLAMP - 2 1/2"	1	
22		278765001	FITTING-#32 FLANGE X 2" HB ST.	1	
23		296274580	SUPPORT - PUMP	1	
24		278842001	PLATE - PUMP SUPPORT	1	
25		251238001	PLATE - LIFT POINT	1	
26		240334001	SCREW-HCS-.50-13X1.75-GR8-YZ	6	
27		250512001	NUT- 1/2 NC Gr8 TOP LOCK Y/ ZINC	2	
28		278981001	HUB - 14T PUMP DRIVE	1	
29		278947001	FITTING-STR-4MORFF-6MORB	2	
30		53826001	#10M O-RING-#8M JIC ST.	1	
31		294561001	FITTING - STR- 4MORFF - 4MORB - R.063	2	

Components-90 Series 55cc Fig 6-3z01



## Components-90 Series 55cc Fig 6-3z01

REF. NO.	*	PART NO.	DESCRIPTION	QTY.	REMARKS
1		278884003	EDC KIT W/ 4-WAY PACKARD CONNECTOR	1	
3		224413005	GASKET-CONTROL	1	
3		278884005	PRESSURE CONTROL PILOT VALVE	1	
2		85642007	VALVE-MULTI-FUNCTION	2	Specify Pressure Setting
2		85642009	O-RING	1	Outer
2		85642011	O-RING	1	Inner
3		85642051	FILTRATION-INTEGRAL SHT FILTER	1	
3		81902001	FILTER-OIL	1	
4		98688009	LIP SEAL	1	
4		98688011	SEAL-CARRIER	1	
4		98688013	O-RING	1	
5		278884001	PUMP - HYD 90 SERIES 55CC	1	Complete

Components-PFC/Implement Fig 6-3z02

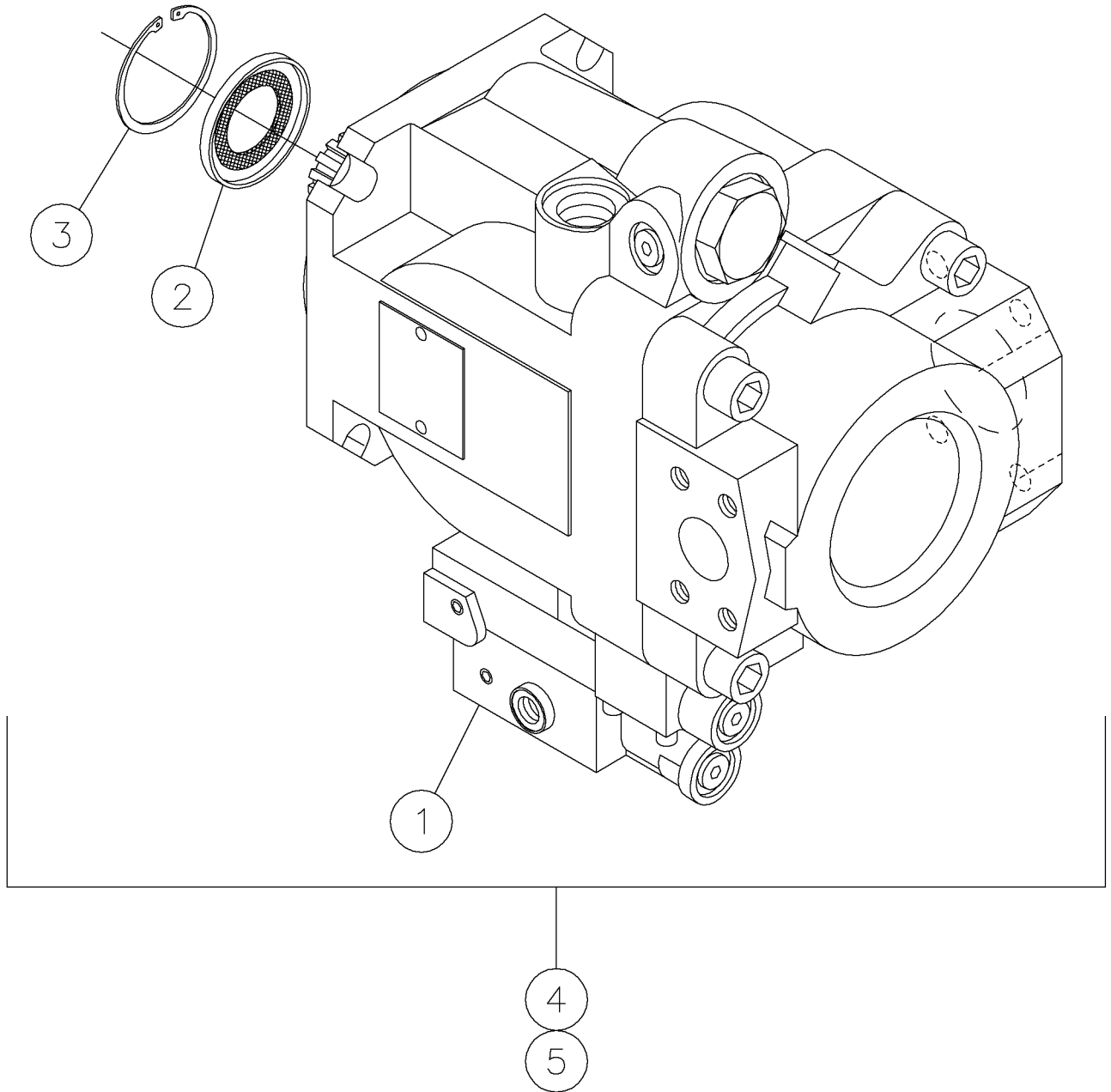



## Components-PFC/Implement Fig 6-3z02

REF. NO.	*	PART NO.	DESCRIPTION	QTY.	REMARKS
1		278885003	CONTROLLER KIT	1	
		278885005	O-RING	4	
2		278885007	LIP SEAL	1	
3		278885009	RETAINING RING	1	
4		278885011	SEAL KIT - OVERHAUL	1	
5		278885001	PUMP - HYDRAULIC 45 SERIES 74CC	1	

Valve-Proportional/Dump Fig 6-4

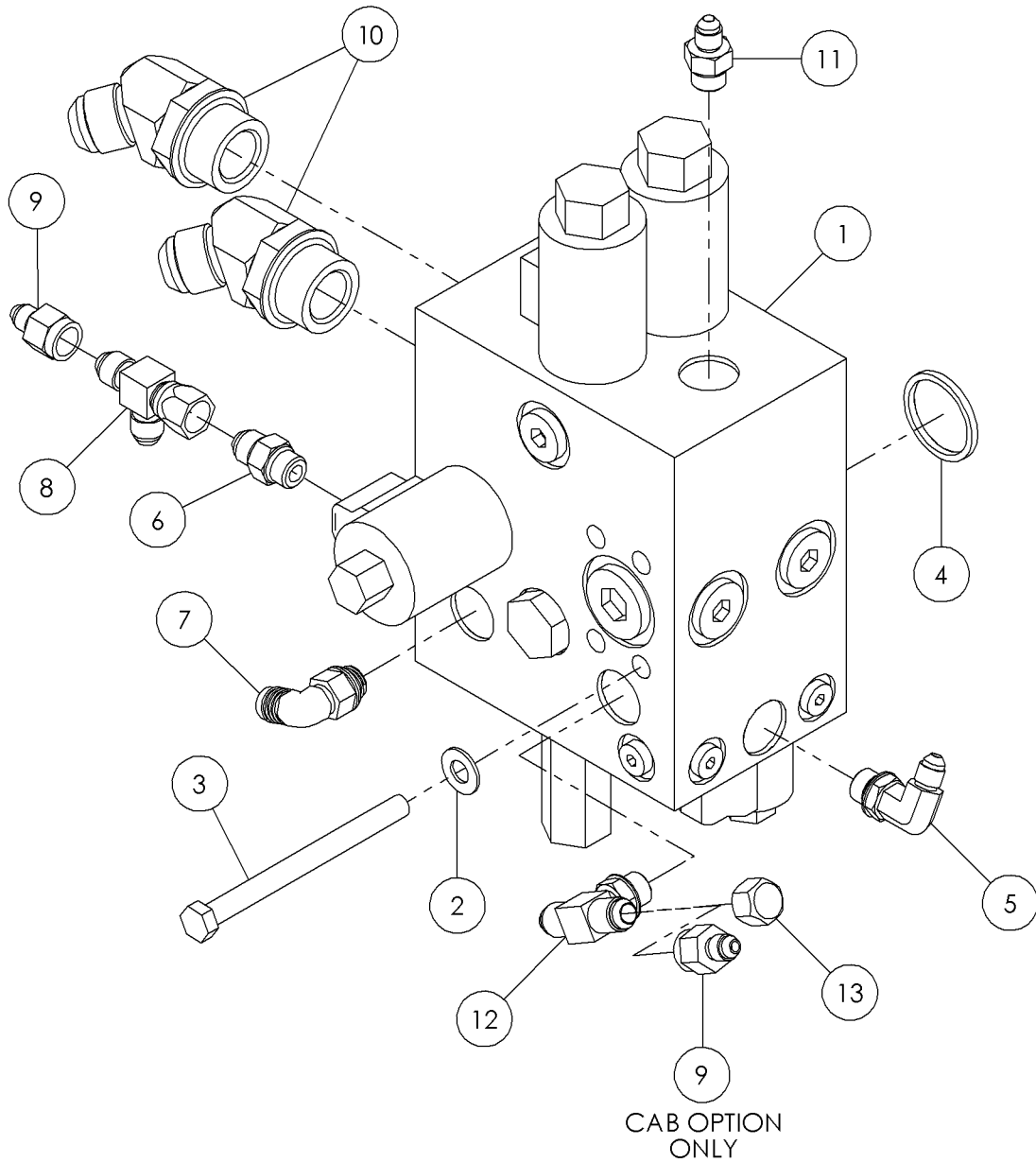
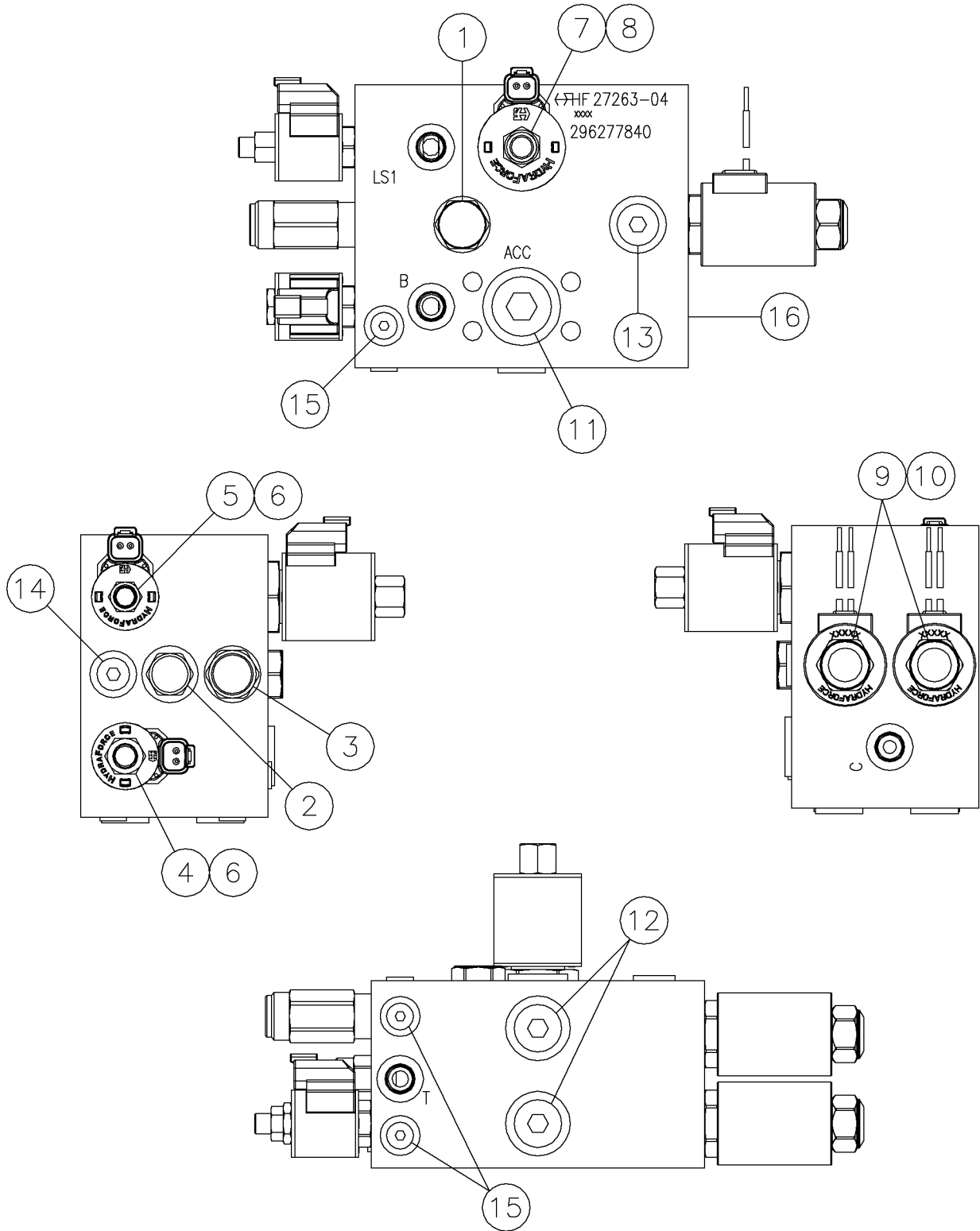

Illustration No. 296279918

## Valve-Proportional/Dump Fig 6-4

REF. NO.	*	PART NO.	DESCRIPTION	QTY.	REMARKS
1		296277840	VALVE - PROPORTIONAL/DUMP	1	Breakdown Fig. 6-4z01
2		235713001	WASHER-FLATSTRL-.38-.41X.81-.06-YA-A325	4	
3		238246001	BOLT 3/8"-16 X 4 1/2" GR8 HEX	4	
4		72895001	O RING-SQ. #16 FLANGE	1	
5		57950001	FITTING-90-4MJ-6MORBA	1	
6		65565001	FITTING - 6M O-RING X 6M JIC ST.	1	
7		59426001	FITTING - 90-6MJ-6MORBA	1	
8		59427001	TEE-6MJ-6FSJ-6MJ	1	
9		59928001	6F JICX4M JIC ST REDUCER	2	Cab Option Only
10		81212001	FITTING-16MX12M JIC 45 ELBOW	2	
11		57968001	FITTING-STR-4MJ-6MORB	1	
12		68787001	FITTING-6M (BCH)X6M JICX6M JIC	1	
13		59403001	CAP NUT - 6 JIC	1	

Components-Valve Proportional/Dump Fig 6-4z01



## Components-Valve Proportional/Dump Fig 6-4z01

REF. NO.	*	PART NO.	DESCRIPTION	QTY.	REMARKS
1		296251271	VALVE-HIGH PRESSURE CHECK	1	
1		251117005	SEAL KIT	1	
2		296251244	PRESSURE REGULATOR	1	
2		296251054	SEAL KIT	1	
3		296251245	RELIEF - HIGH PRESSURE	1	
1		296285062	SEAL KIT	1	
4		250131005	CARTRIDGE - 2 WAY NC HP	1	
4		296265595	SEAL KIT	1	
5		296285063	SOLENOID VALVE	1	
5		296251054	SEAL KIT	1	
6		296271115	COIL	2	
7		296285064	SOLENOID VALVE	1	
7		296285065	SEAL KIT	1	
8		296271077	COILS	1	
9		296251247	PROPORTIONAL FLOW CONTROL	2	
9		296251250	SEAL KIT	1	
10		282520003	SOLENOID - #10 W/LEADS DEUTSCH SOCKETS	2	
11		251117019	PORT PLUG	1	
12		251107011	PORT PLUG - SAE 10	2	
13		236494005	PLUG-SAE	1	
14		500659021	SAE PLUG	1	
15		240324011	PLUG-SAE	3	
16			BLOCK	1	Not Sold Separately
		296277840	VALVE - PROPORTIONAL/DUMP		Includes All Items In Figure

Valve-Torque/Thrust Limiter Fig 6-5

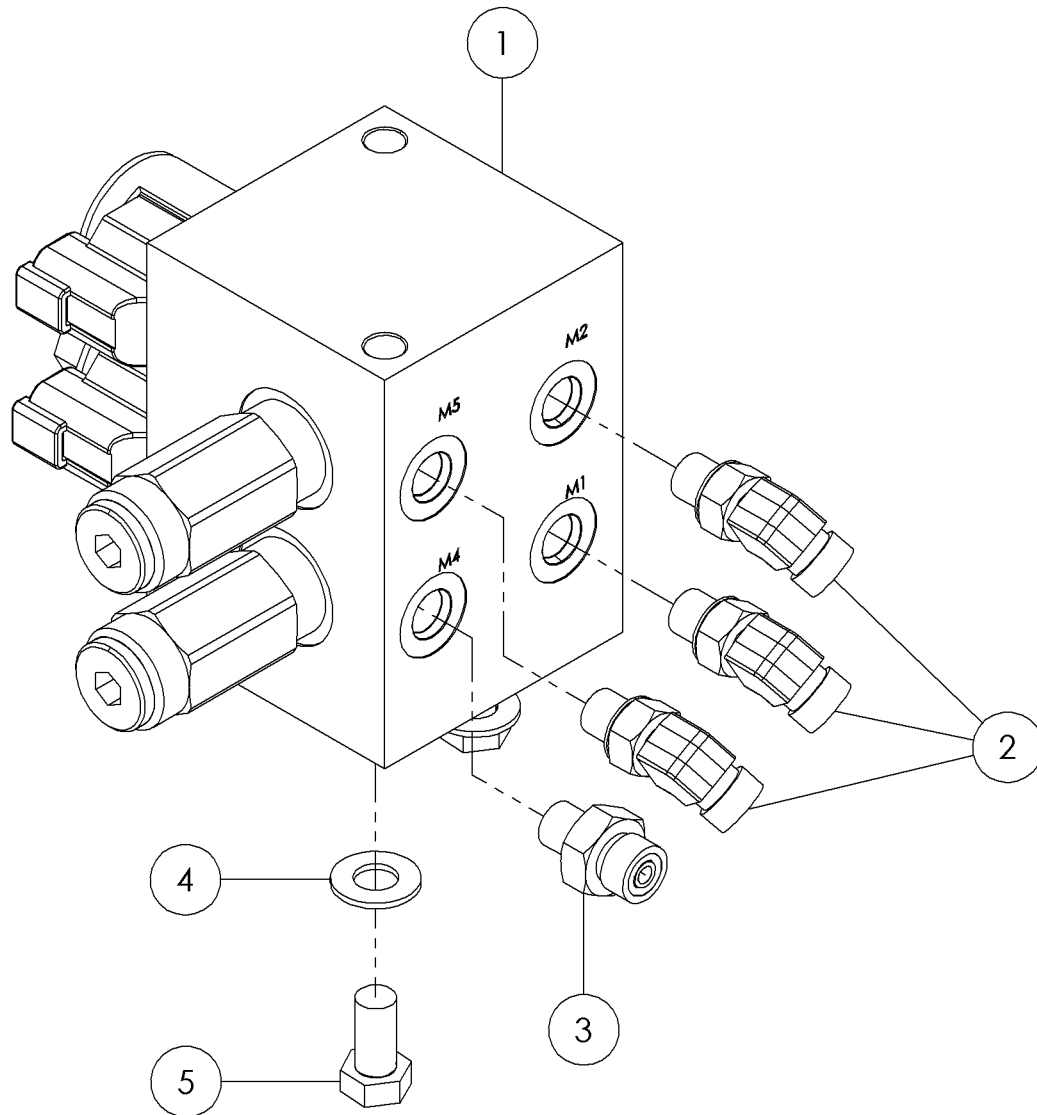

## Valve-Torque/Thrust Limiter Fig 6-5

REF. NO.	*	PART NO.	DESCRIPTION	QTY.	REMARKS
1		296269561	VALVE - TORQUE LIMITER	1	Breakdown Fig. 6-5z01
2		72450001	FITTING - 45 - 4MORFF - 4MORBA - FRG	3	
3		72449001	FITTING - STR - 4MORFF - 4MORB	1	
4		235713001	WASHER-FLATSTRL-.38-.41X.81-.06-YA-A325	2	
5		235726001	BOLT-3/8-16X3/4 GR8 HEX ZNCPLT	2	

Components-Torque Fig 6-5z01

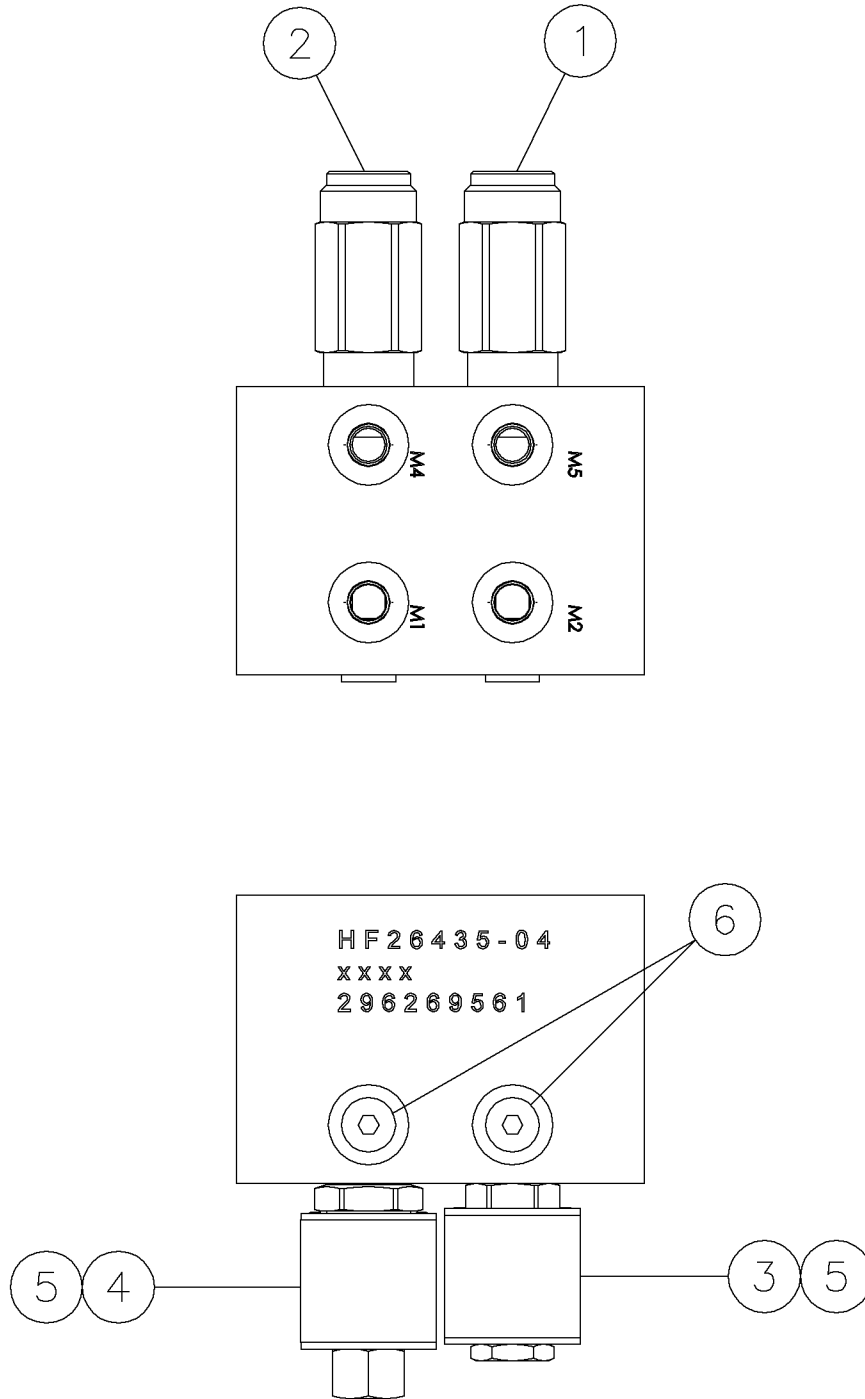



## Components-Torque Fig 6-5z01

REF. NO.	*	PART NO.	DESCRIPTION	QTY.	REMARKS
1		251120007	RELIEF - HIGH PRESSURE	1	
1		296271087	SEAL KIT	1	
2		296272925	RELIEF VALVE	1	
2		296271087	SEAL KIT	1	
3		251120003	POPPET - 2 WAY N/C	1	
3		296265595	SEAL KIT	1	
4		296272926	SOLENOID VALVE	1	
1		296265595	SEAL KIT	1	
5		296271115	COIL	2	
6		240324011	PLUG-SAE	2	
		296269561	VALVE - TORQUE LIMITER		Includes All Items In Figure

Valve-Return Fig 6-6

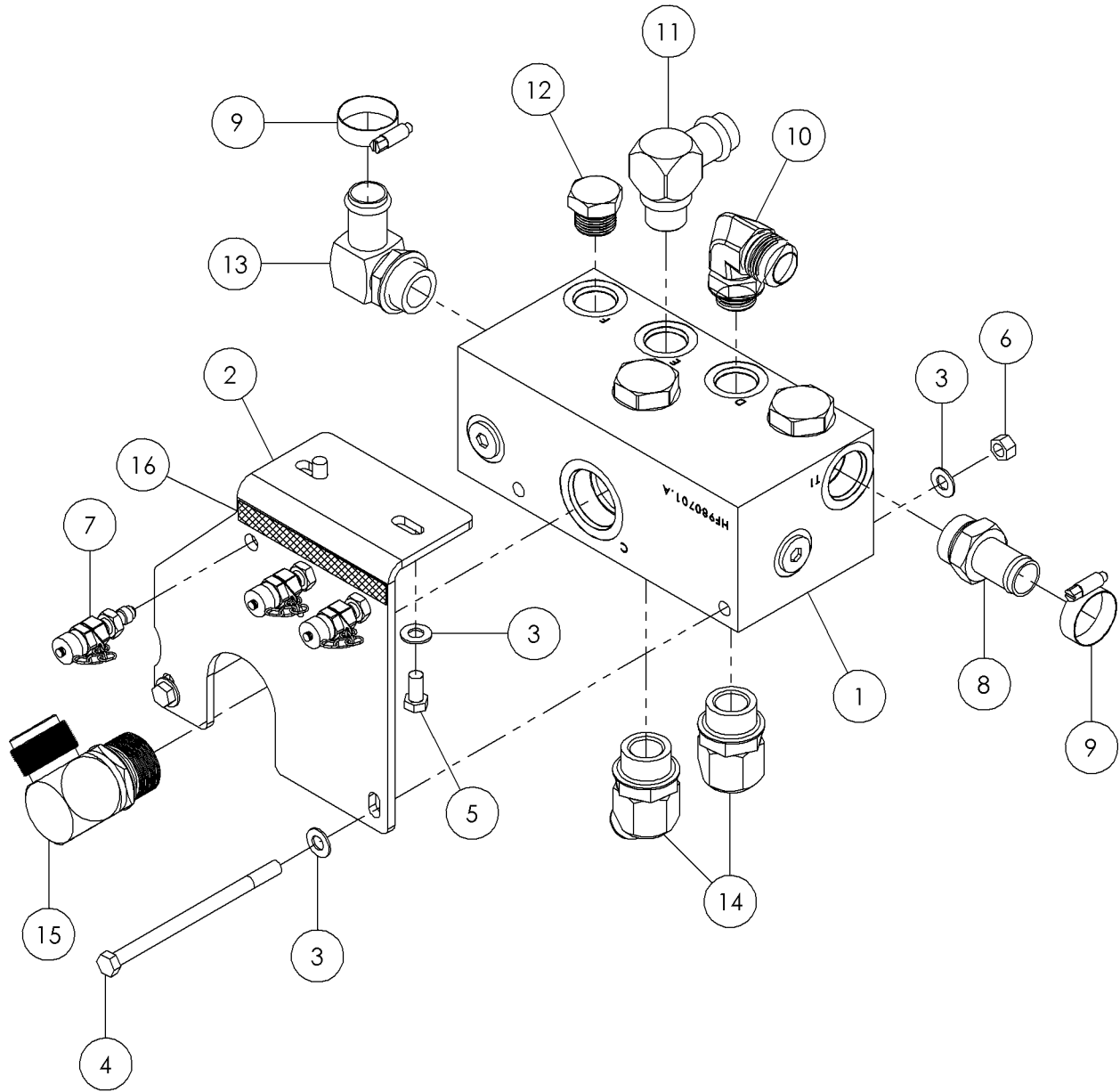
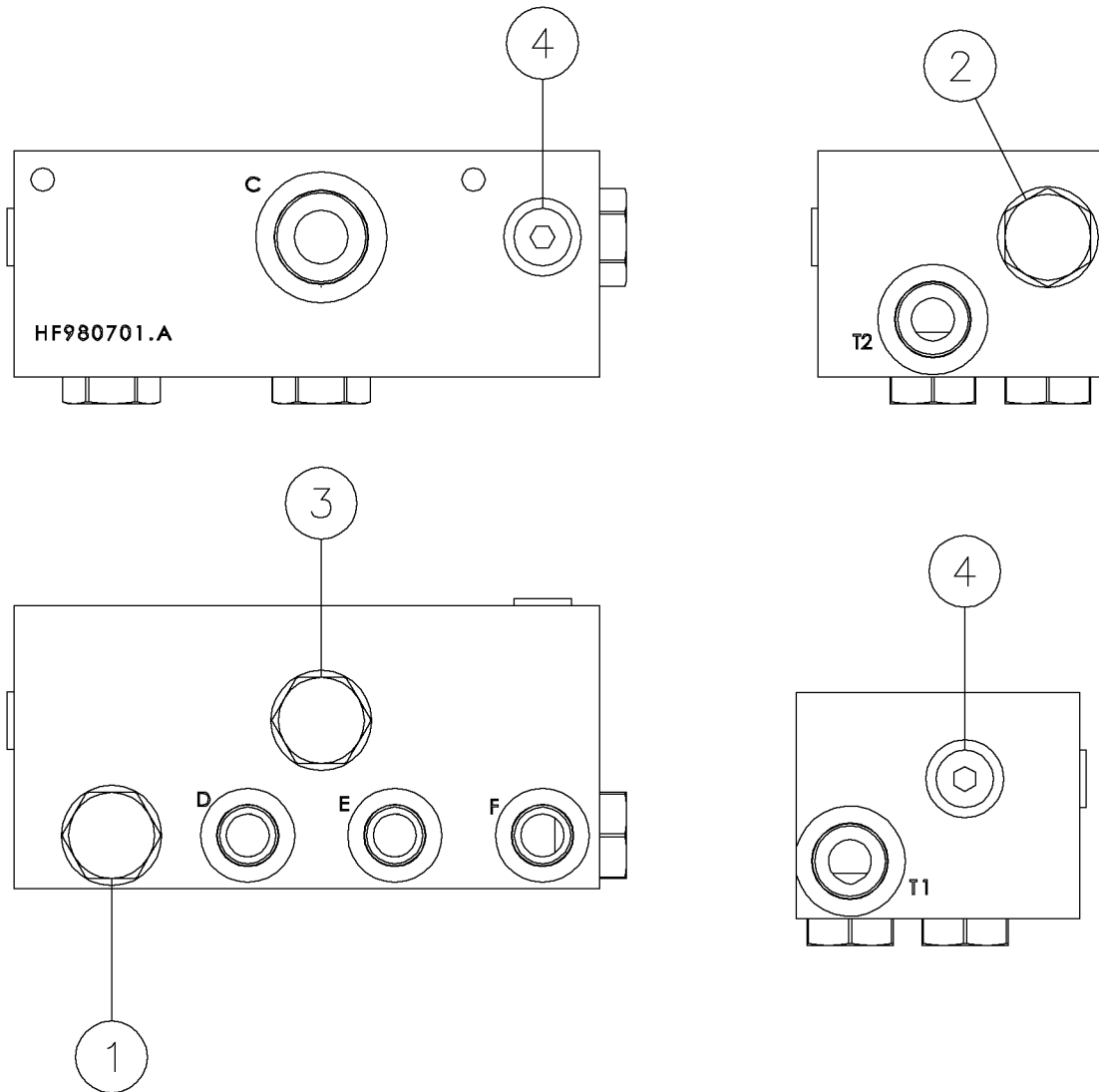

Illustration No. 296279923

## Valve-Return Fig 6-6

REF. NO.	*	PART NO.	DESCRIPTION	QTY.	REMARKS
1		296273651	MANIFOLD - RETURN	1	Breakdown Fig. 6-6z01
2		278752001	PLATE-RETURN VALVE MOUNT	1	
3		235713001	WASHER-FLATSTRL-.38-.41X.81-.06-YA-A325	6	
4		238214001	BOLT 3/8-16 X 6" Gr8 HEX YZINC	2	
5		235726001	BOLT-3/8-16X3/4 GR8 HEX ZNCPLT	2	
6		235725001	NUT - HEX - .38 - 16 - GR8 - YZ	2	
7		86230001	FITTING-MALE BLKHD CPLG7/16JIC	3	
8		96709001	HOSE INSERT-16MX1 BEAD STR.	1	
9		238094001	CLAMP-3/4X1 3/4 BAND W/SCREW	2	
10		65571001	12M X 16M JIC 90 DEGREE	1	
11		99706001	FITTING-12MORX1"HOSEBEAD 90DEG	1	
12		67570001	FITTING - PLUG - 12MORB - HEX	1	
13		100000001	FITTING-16MORINGX1"BEADED90DEG	1	
14		81212001	FITTING-16MX12M JIC 45 ELBOW	2	
15		77137001	FITTING-20MX20M JIC 90 DEG.	1	
16		7000B300	DECAL - TEST POINT	1	

Components-Valve Return Fig 6-6z01



## Components-Valve Return Fig 6-6z01

REF. NO.	*	PART NO.	DESCRIPTION	QTY.	REMARKS
1		251107007	VALVE - CHECK	1	
2		251107009	VALVE - CHECK	1	
3		251107003	VALVE - CHECK	1	
4		251107011	PORT PLUG - SAE 10	1	
		296273651	MANIFOLD - RETURN		Includes All Items In Figure

Valve-Remote Lockout Fig 6-7

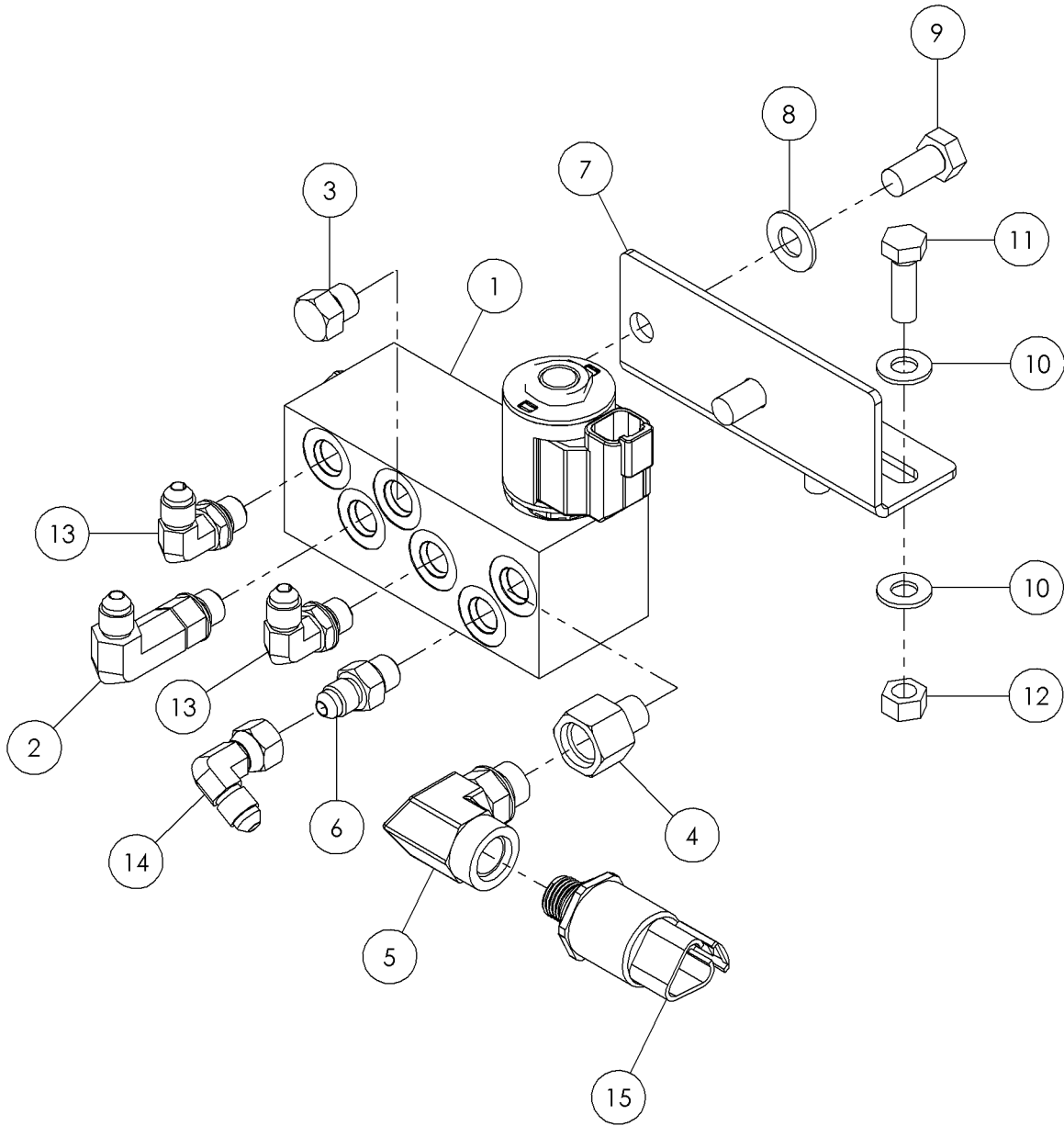
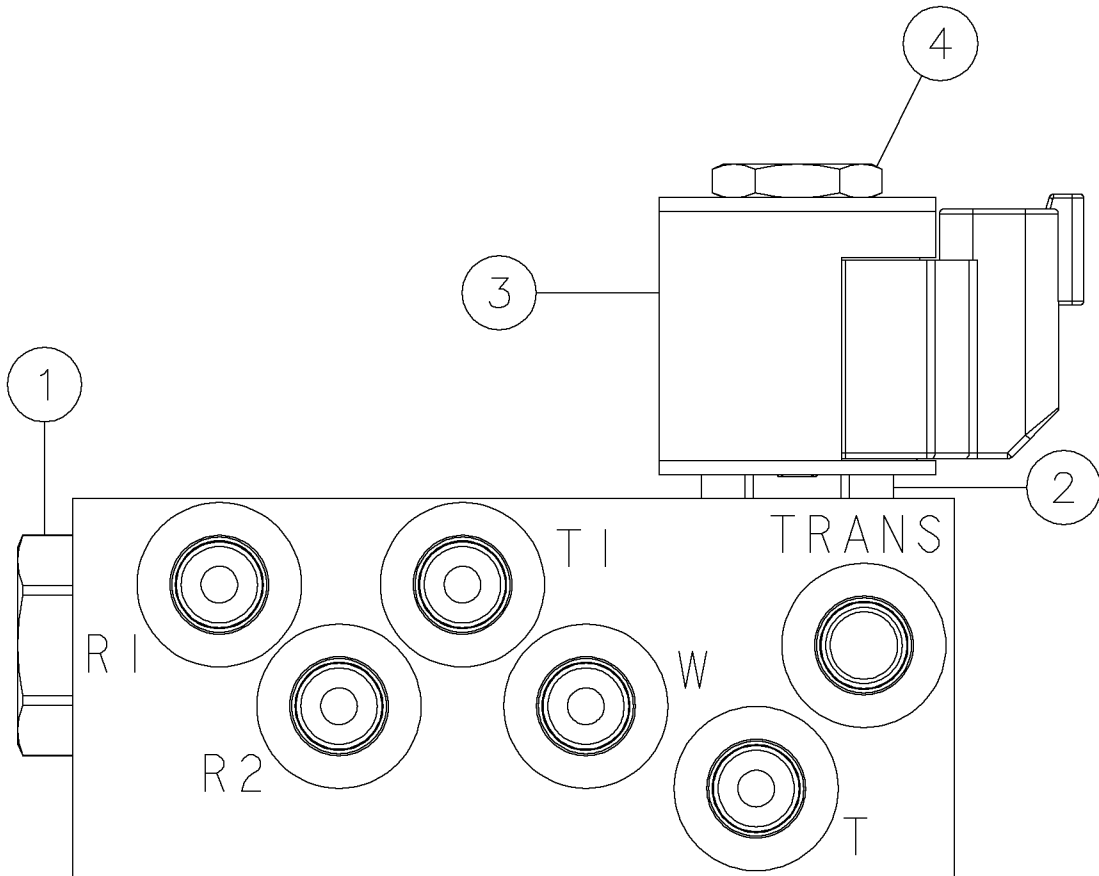

Illustration No. 296279924

## Valve-Remote Lockout Fig 6-7

REF. NO.	*	PART NO.	DESCRIPTION	QTY.	REMARKS
1		296278540	VALVE - CHECK BANK	1	Breakdown Fig. 6-7z01
2		249977001	FITTING - 4MOR X 4MJIC 90 LONG	1	
3		67263001	FITTING - PLUG - 4MORB - HEX	1	
4		88530001	FITTING-4MORB X 6FORB SOLID REDUCER	1	
5		296259050	FITTING - 6FOR X 6MOR FORGED ELBOW	1	
6		60908001	FITTING-4MX4M JIC STR ADAPTER	1	
7		296280981	BRACKET- REMOTE LOCKOUT VALVE	1	
8		235713001	WASHER-FLATSTRL-.38-.41X.81-.06-YA-A325	2	
9		235726001	BOLT-3/8-16X3/4 GR8 HEX ZNCPLT	2	
10		235714001	WASHER-FLATSTRL-.31-.34X.69-.06-YZ-A325	4	
11		238209001	BOLT-5/16-18X1 GR8 HEX ZINC YC	2	
12		235741001	NUT - HEX - .31 - 18 - GR8 -YZ	2	
13		59423001	FIT-4M JICX4M ADJ.90 DEG.ELBOW	2	
14		53658001	FITTING-4M JICX4 FS JIC 90 DEG	1	
15		296276082	TRANSDUCER 6000 PSI HYDAC	1	

Components-Valve Remote Lockout Fig 6-7z01





## Components-Valve Remote Lockout Fig 6-7z01

REF. NO.	*	PART NO.	DESCRIPTION	QTY.	REMARKS
1		296276754	LOAD SENSE VALVE	1	
1		296276755	SEAL KIT	1	
2		251120003	POPPET - 2 WAY N/C	1	
2		296271087	SEAL KIT	1	
3		296271115	COIL	1	
4		224886007	NUT	1	
		296278540	VALVE - CHECK BANK		Includes All Items In Figure

Cylinder-Gearbox Lock Fig 6-8

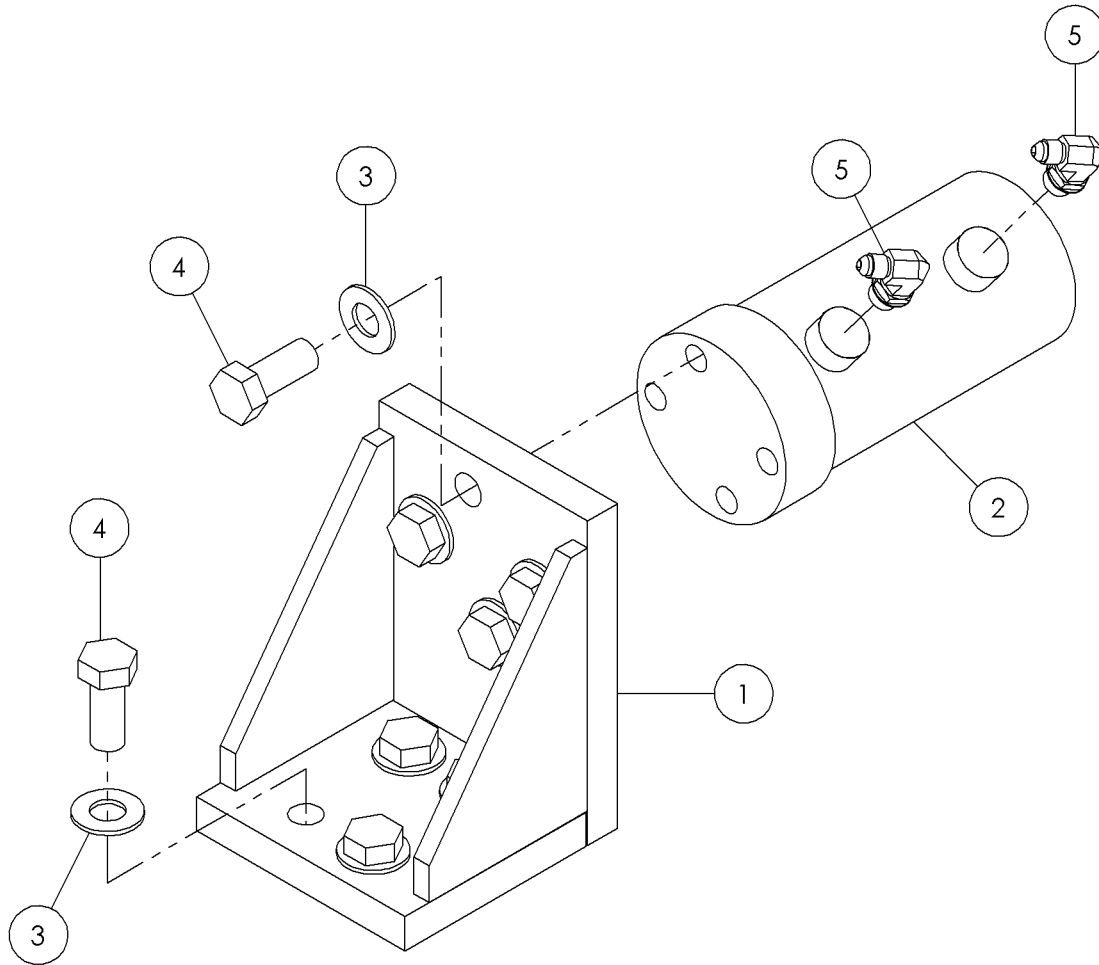
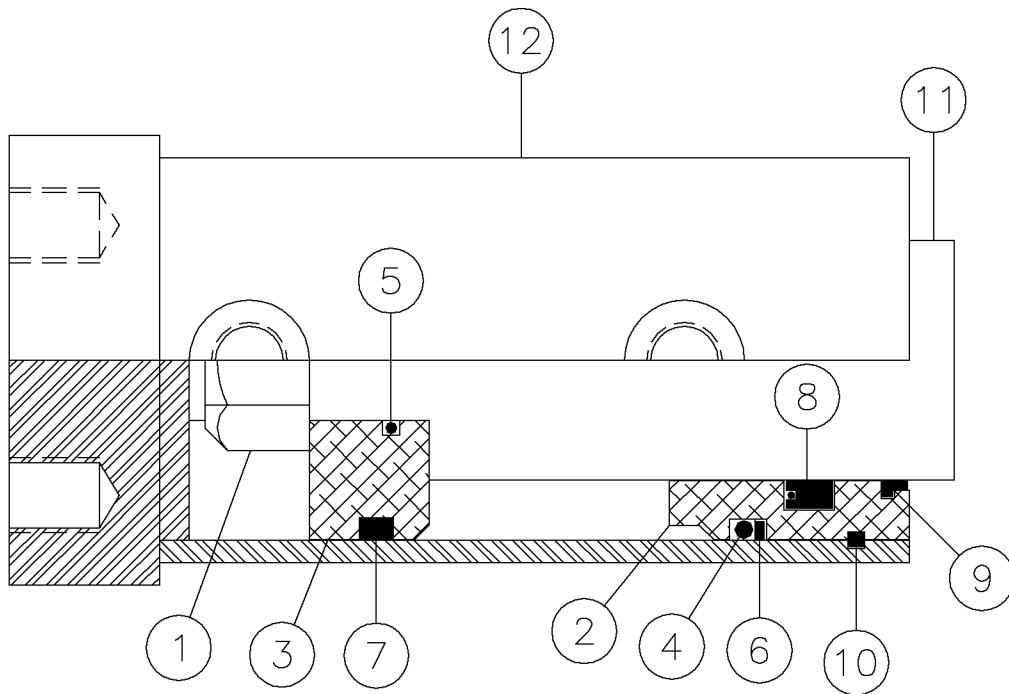

Illustration No. 296279933

## Cylinder-Gearbox Lock Fig 6-8

REF. NO.	*	PART NO.	DESCRIPTION	QTY.	REMARKS
1		296280970	BRACKET - LOCK CYLINDER	1	
2		278306001	CYLINDER - HYDRAULIC LOCK	1	Breakdown Fig. 6-8z01
3		235715001	WASHER-FLATSTRL-5/8" YZ A325	8	
4		230727001	BOLT-5/8-11X1 1/2GR8 PLATED	8	
5		57950001	FITTING-90-4MJ-6MORBA	2	

Components-Cylinder Gearbox Lock Fig 6-8z01



## Components-Cylinder Gearbox Lock Fig 6-8z01

REF. NO.	*	PART NO.	DESCRIPTION	QTY.	REMARKS
1		236113003	NUT	1	
2		278306002	HEAD - CYLINDER	1	
3		278306003	PISTON - CYLINDER	1	
4			O-RING	1	Not Sold Separately
5			O-RING	1	Not Sold Separately
6			BACKUP	1	Not Sold Separately
7			PSP SEAL	1	Not Sold Separately
8			POLYPACK	1	Not Sold Separately
9			DUST SEAL	1	Not Sold Separately
10			RETAINING RING	1	Not Sold Separately
11		278306004	SHAFT - CYLINDER	1	
12		278306005	BARREL W/ PORTS	1	
		278306006	REPAIR KIT	1	Includes Ref. 4-9
		278306001	CYLINDER - HYDRAULIC LOCK	1	Includes All Items In Figure

Valve-Pressure Gauge Shuttle Fig 6-9

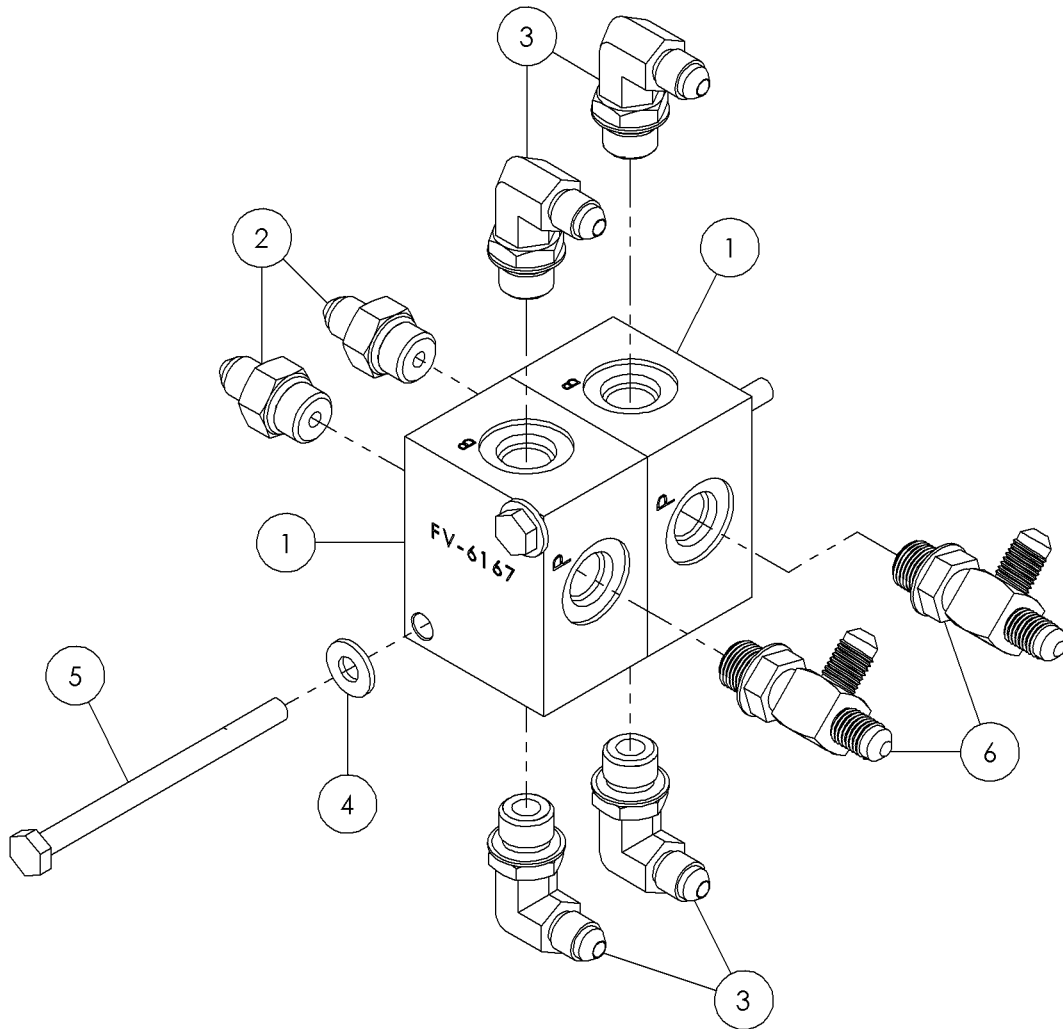

Illustration No. 296279919

## Valve-Pressure Gauge Shuttle Fig 6-9

REF. NO.	*	PART NO.	DESCRIPTION	QTY.	REMARKS
1		296260411	VALVE - SHUTTLE	2	
2		57968001	FITTING-STR-4MJ-6MORB	2	
3		57950001	FITTING-90-4MJ-6MORBA	4	
4		252251001	WASHER-1/4 SAE FLAT ZP	2	
5		244204001	SCREW-HCS-.25-20X3.50-GR8-YZ-SP	2	
6		82930001	FIT-6MX4M JICX4M JIC (RUN) TEE	2	

Valve-3 Speed Gearbox Fig 6-10

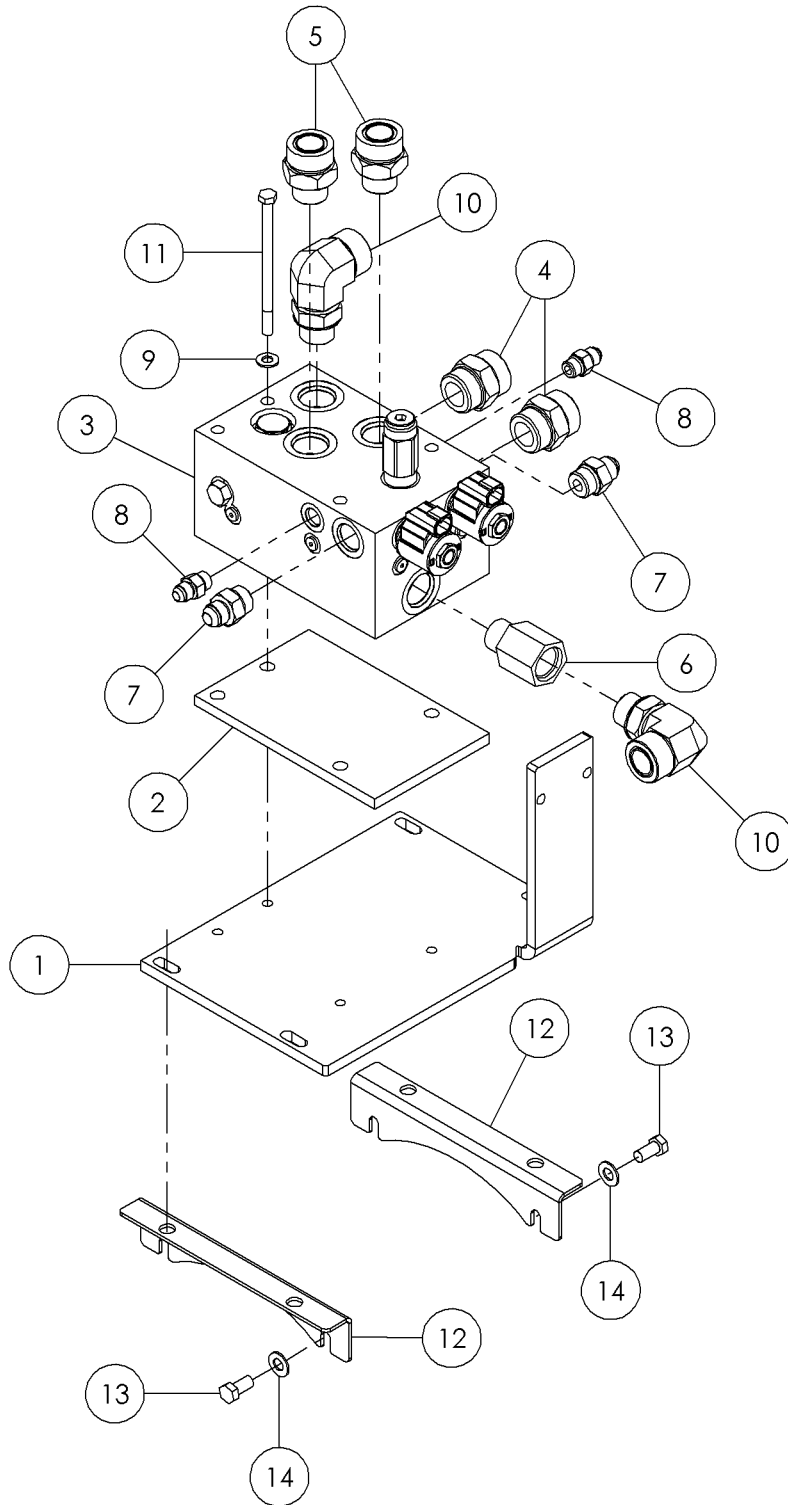

Illustration No. 296279920



Valve-3 Speed Gearbox Fig 6-10

REF. NO.	*	PART NO.	DESCRIPTION	QTY.	REMARKS
1		296284013	MOUNT - VALVE	1	
2		296280435	PLATE - VALVE SPACER	1	
3		296269674	VALVE - 3 SPEED FLUSH 3 GPM	1	Breakdown Fig. 6-10z01
4		72407001	FITTING - STR - 16MORFF - 16MORB	2	
5		278957001	FITTING - 12 MOR X 16 MFFOR	2	
6		296280967	FITTING - STR 12 MORB - 12FORB LONG	1	
7		53826001	#10M O-RING-#8M JIC ST.	2	
8		65565001	FITTING - 6M O-RING X 6M JIC ST.	2	
9		235714001	WASHER-FLATSTRL-.31-.34X.69-.06-YZ-A325	2	
10		72971001	FITTING-16-12C50L0	2	
11		248069001	BOLT-5/16-18X5 GR 8 YZ	2	
12		296284011	MOUNT - GEARBOX VALVE	2	
13		235726001	BOLT-3/8-16X3/4 GR8 HEX ZNCPLT	4	
14		235713001	WASHER-FLATSTRL-.38-.41X.81-.06-YA-A325	4	

Components-Valve 3 Speed Gearbox Fig 6-10z01

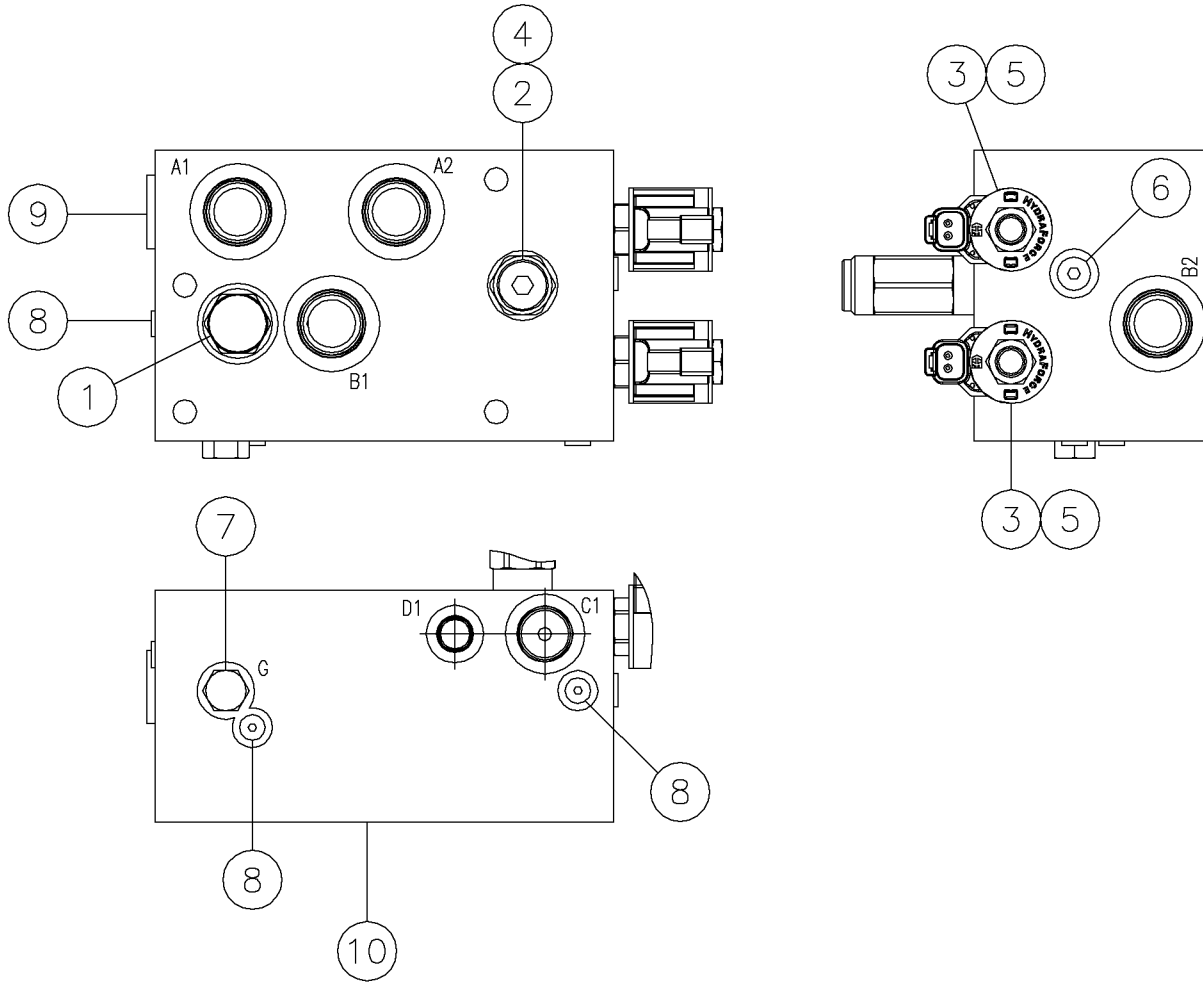

## Components-Valve 3 Speed Gearbox Fig 6-10z01

REF. NO.	*	PART NO.	DESCRIPTION	QTY.	REMARKS
1		251117003	SHUTTLE - HOT OIL (SPRINGLESS)	1	
1		296285082	SEAL KIT	1	
2		296251232	VALVE - RELIEF	1	
2		251117013	SEAL KIT	1	
3		161158001	SPOOL-3 WAY	2	
3		161159001	SEAL KIT	2	
4		296285176	ORIFICE	1	
5		296271115	COIL	2	
6		240324011	PLUG-SAE	1	
7		296285081	PLUG	1	
8		240324015	PLUG-SAE	5	
9		251117019	PORT PLUG	1	
10			BLOCK		Not Sold Separately
		296269674	VALVE - 3 SPEED FLUSH 3 GPM		Includes All Items In Figure

Hose Carrier & Tower (10') Fig 6-11

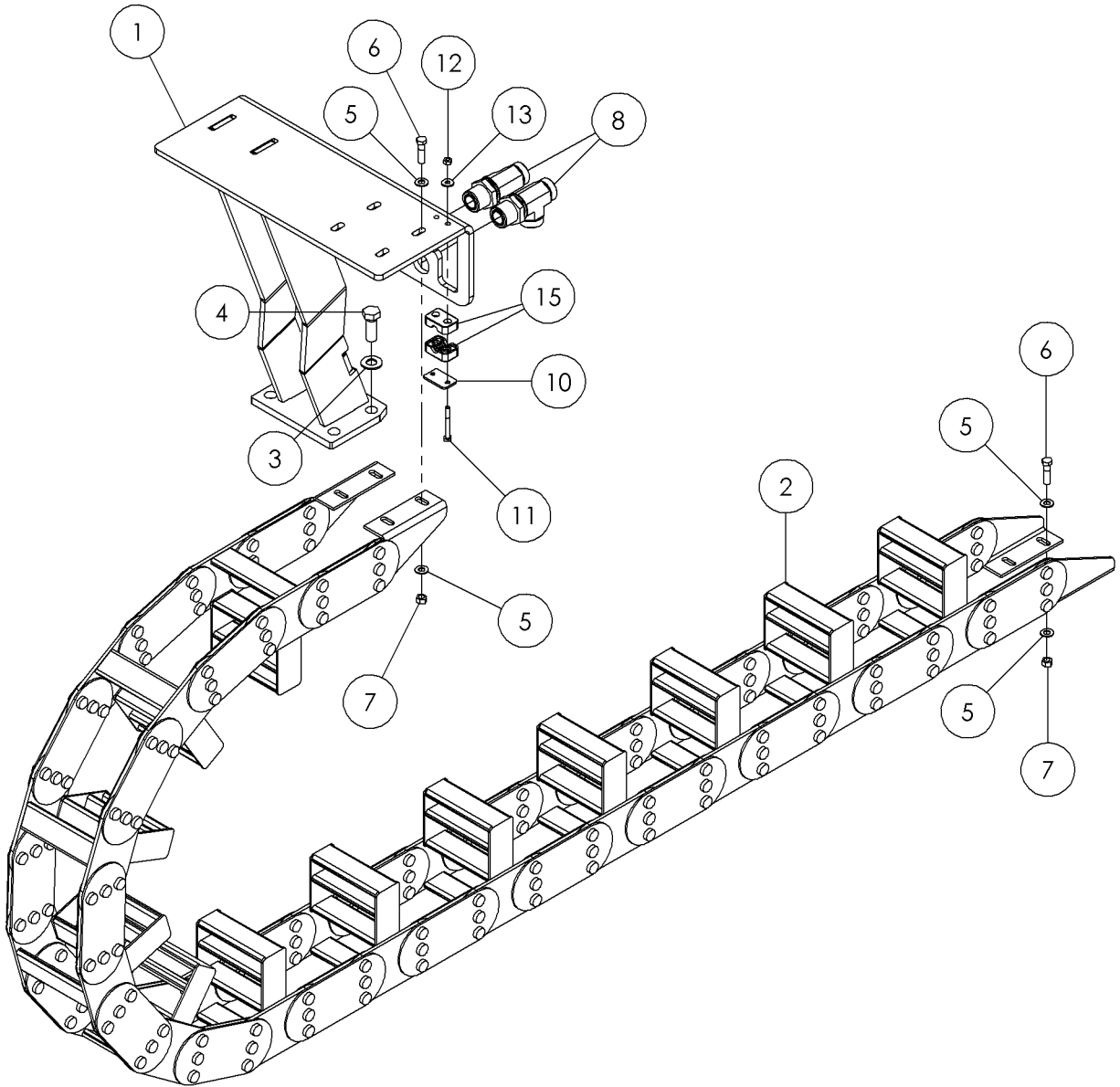
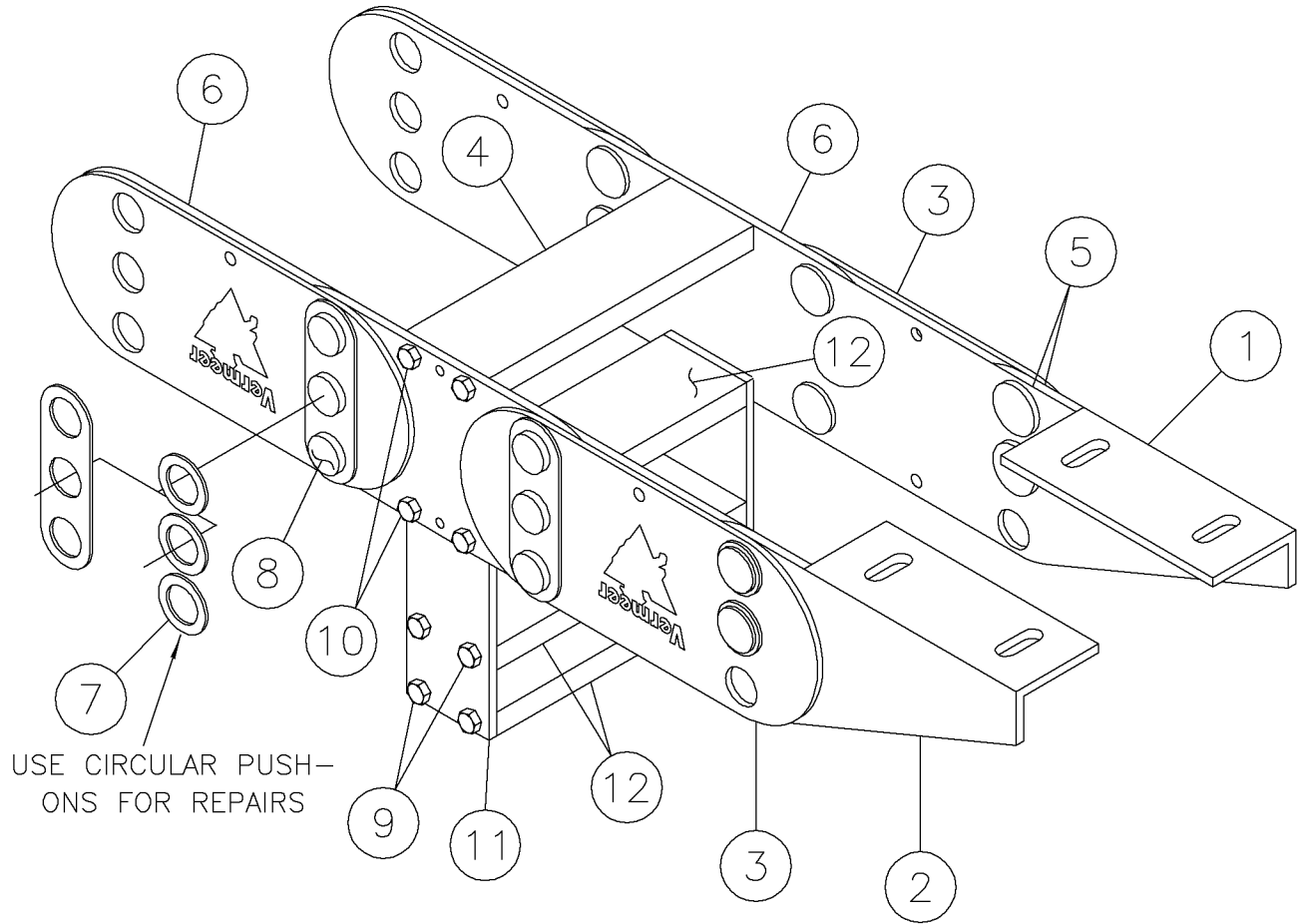

Illustration No. 296279932

## Hose Carrier &amp; Tower (10') Fig 6-11

REF. NO.	*	PART NO.	DESCRIPTION	QTY.	REMARKS
1		296280985	TOWER - HOSE TRACK	1	
2		294636001	TRACK - HOSE CARRIER 10'	1	Breakdown Fig. 6-11z01
3		235715001	WASHER-FLATSTRL-5/8" YZ A325	4	
4		230728001	BOLT-5/8-11X1 3/4GR 8 PLATED	4	
5		235713001	WASHER-FLATSTRL-.38-.41X.81-.06-YA-A325	16	
6		235723001	SCREW - HCS -.38 - 16 X 1.50 - GR8 - YZ	8	
7		250508001	NUT - 3/8-NC Gr8 TOP LOCK Y/ZINC	8	
8		296284064	FITTING-BHRTEE 16MORFF-16MORFF-16MORFF-L	2	
9		904738003	1/4 SINGLE HOSE CLAMP	2	
10		901678007	PLATE-COVER COP-3	1	
11		250644001	BOLT-1/4-20 X2 1/4 GR 8 Y/ZINC	2	
12		510313501	NUT-TLHEX-.25-20-A-YZ	2	
13		510337603	WASHER-FLATSTD-.25-.31X.75-.07-YZ	2	

Components-Hose Track (10') Fig 6-11z01



## Components-Hose Track (10') Fig 6-11z01

REF. NO.	*	PART NO.	DESCRIPTION	QTY.	REMARKS
1		234256003	PT45E MOUNTING BRACKET ASSY (L	2	
2		234256005	PT45E MOUNTING BRACKET ASSY(R)	2	
3		234256007	PT45E OUTER LINK W/VERMEERLOGO	52	
4		276280011	PT45E ALUM CHANNEL 5.825"	15	
5		234256011	PT45E ANTI-FRICTION DISC	106	
6		276280003	PT45E INNER LINK R13.39	52	
7		234256015	PT45E CIRCULAR PUSH-ON	150	
8		234256017	PT45E HINGE PIN-PUSH ON FASTNR	150	
9		215252017	SCREW-WHIZ LOCK	148	
10		276280005	SCREW - WHIZ LOCK 10-32 X .62	44	
11		276280007	BRACKET - PT45E CARRIER	22	
12		276280009	PT45E ALUM CHANNEL 5.375"	33	
		294636001	TRACK - HOSE CARRIER 10'	1	Includes All Items In This Figure

Hose Carrier & Tower (15') Fig 6-12

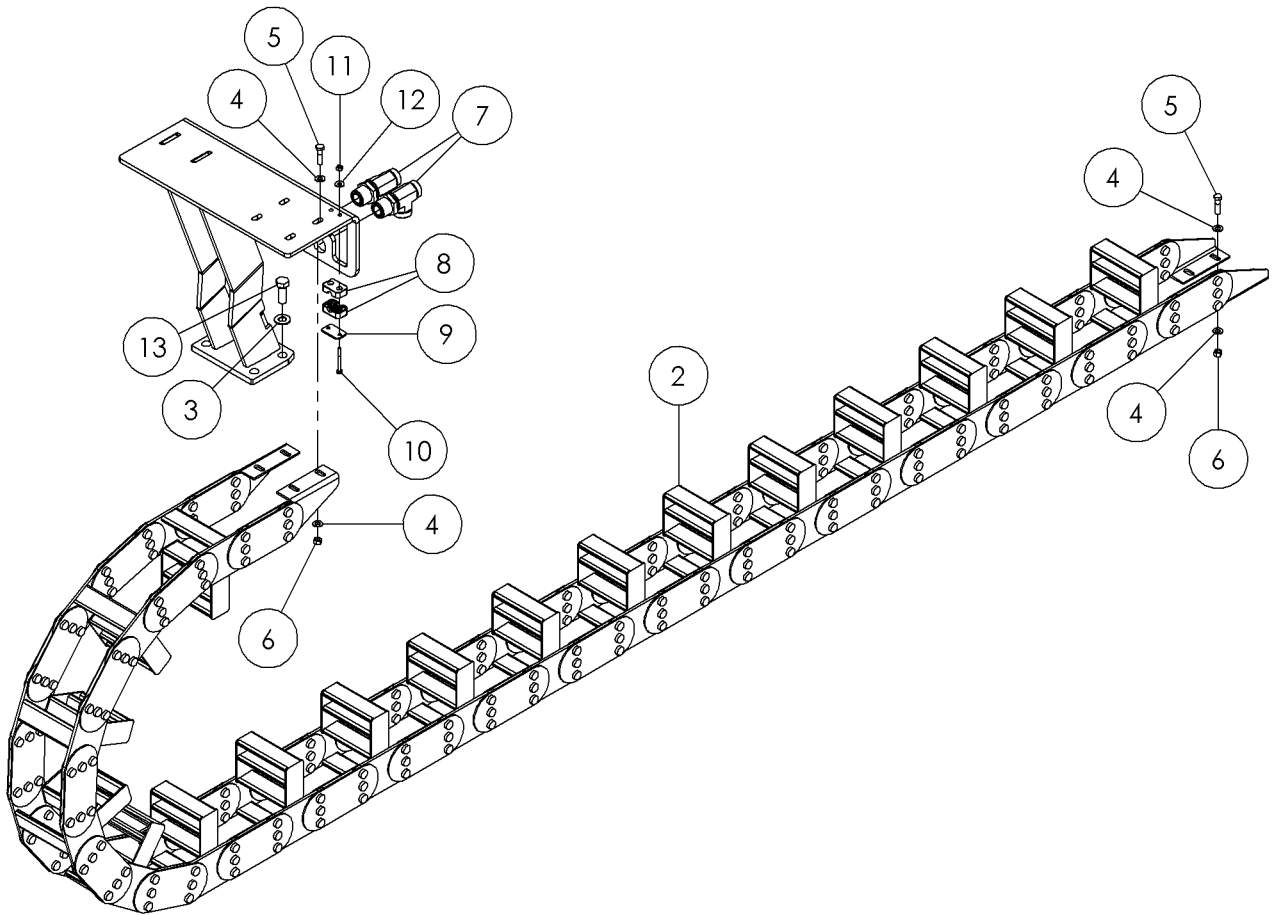

Illustration No. 296279932



## Hose Carrier &amp; Tower (15') Fig 6-12

REF. NO.	*	PART NO.	DESCRIPTION	QTY.	REMARKS
1		296280985	TOWER - HOSE TRACK	1	
2		276280001	TRACK-HOSE CARRIER 15'	1	Breakdown Fig. 6-12z01
3		235715001	WASHER-FLATSTRL-.63-.66X1.31-.09-YZ-A325	4	
4		235713001	WASHER-FLATSTRL-.38-.41X.81-.06-YZ-A325	16	
5		235723001	SCREW-HCS-.38-16X1.50-GR8-YZ	8	
6		250508001	NUT-TLHEX-.38-16-C-YZ	8	
7		296284064	FITTING - BHRTEE - 16MORFF - 16MORFFBH-16MORFF - LN	2	
8		904738003	1/4 SINGLE HOSE CLAMP	2	
9		901678007	PLATE - COVER DP 3	1	
10		250644001	SCREW-HCS-.25-20X2.25-GR8-YZ	2	
11		510313501	NUT-TLHEX-.25-20-A-YZ	2	
12		510337603	WASHER-FLATSTD-.25-.31X.75-.07-YZ	2	
13		230728001	SCREW-HCS-.63-11X1.75-GR8-YZ	4	

Components-Hose Track (15') Fig 6-12z01

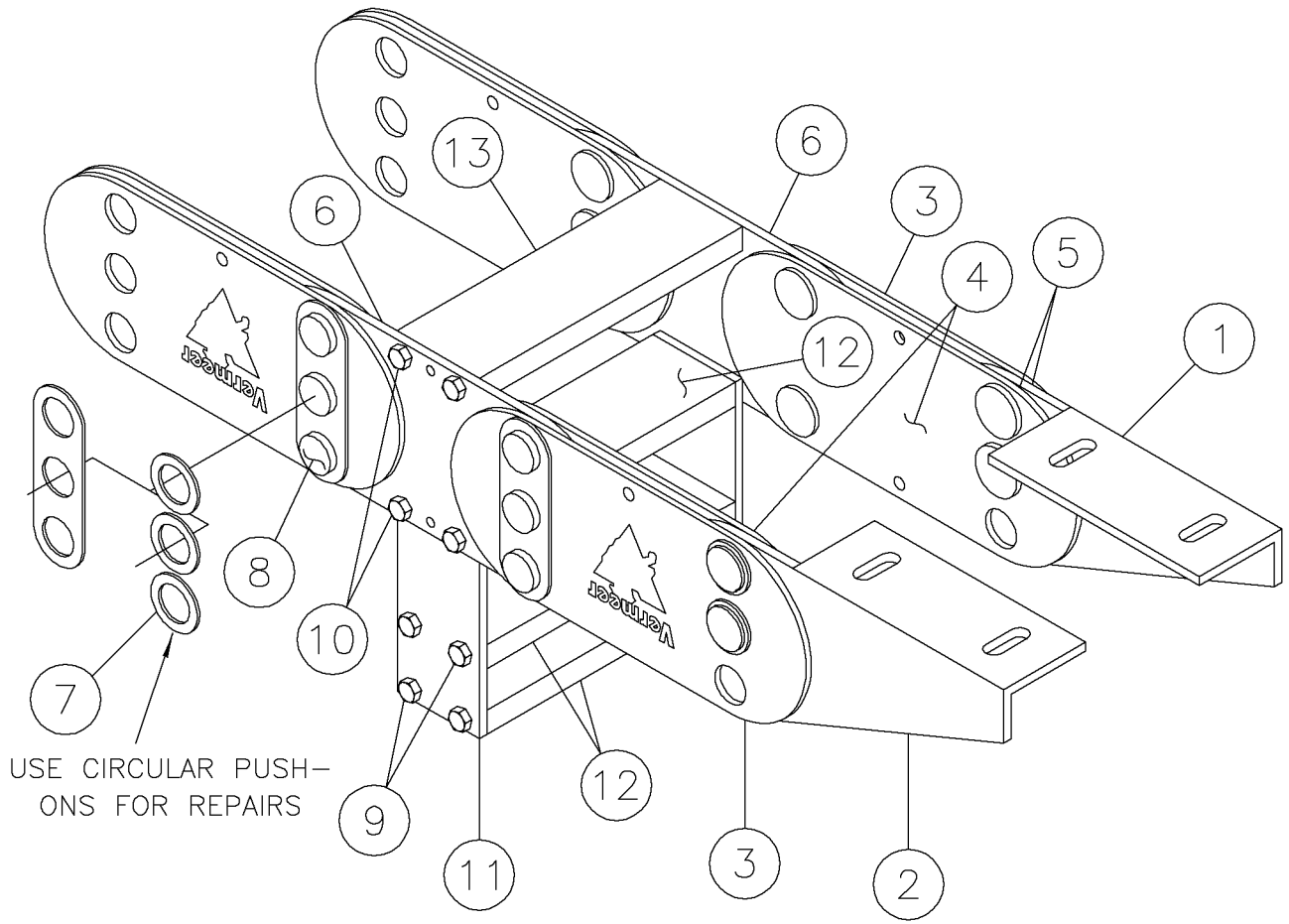

## Components-Hose Track (15') Fig 6-12z01

REF. NO.	*	PART NO.	DESCRIPTION	QTY.	REMARKS
1		234256003	PT45E MOUNTING BRACKET ASSY (L)	2	
2		234256005	PT45E MOUNTING BRACKET ASSY(R)	2	
3		234256007	PT45E OUTER LINK W/VERMEERLOGO	34	
4		234256009	PT45E OUTER LINK	34	
5		234256011	PT45E ANTI-FRICTION DISC	138	
6		276280003	PT45E INNER LINK R13.39	68	
7		234256015	PT45E CIRCULAR PUSH-ON	198	
8		234256017	PT45E HINGE PIN-PUSH ON FASTNR	198	
9		215252017	SCREW-WHIZ LOCK	204	
10		276280005	SCREW - WHIZ LOCK 10-32 X .62	68	
11		276280007	BRACKET - PT45E CARRIER	34	
12		276280009	PT45E ALUM CHANNEL 5.375"	51	
13		276280011	PT45E ALUM CHANNEL 5.825"	17	
		276280001	TRACK - HOSE CARRIER 15'		Includes Items In Figure

Carriage Bulkhead Fittings Fig 6-13

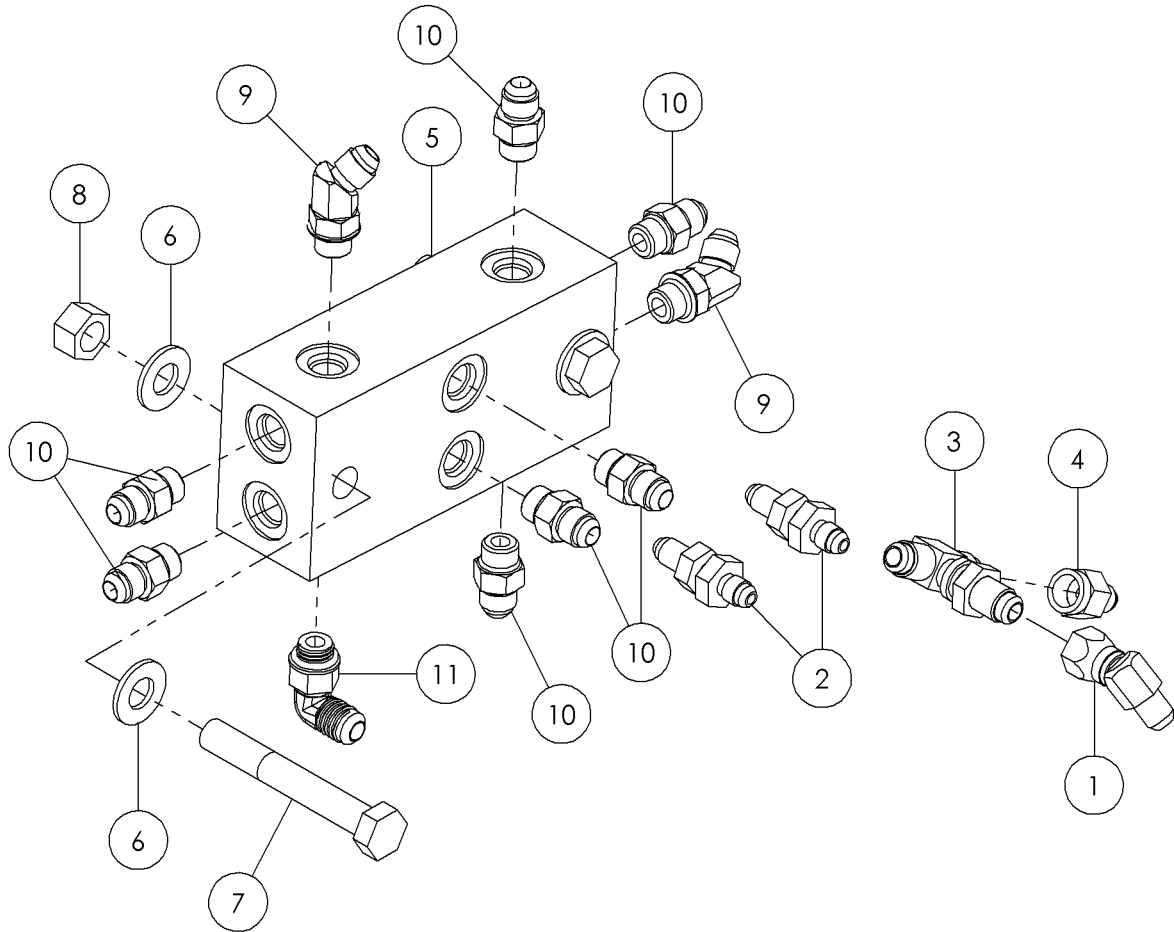

Illustration No. 296279934

## Carriage Bulkhead Fittings Fig 6-13

REF. NO.	*	PART NO.	DESCRIPTION	QTY.	REMARKS
1		59419001	6M JICX6FS JIC 45 DEG.ELBOW	1	
2		65564001	FITTING - 4M JIC BULKHEAD ST.	2	
3		60726001	6M JIC BULKHEAD TEE	1	
4		59928001	6F JICX4M JIC ST REDUCER	1	
5		296282495	BLOCK - MANIFOLD	1	
6		485025	WASHER-1/2 FLAT-HARDENED-YZ	4	
7		238241001	BOLT 1/2"-13X 3 1/2" GR8 HEX	2	
8		250512001	NUT- 1/2 NC Gr8 TOP LOCK Y/ ZINC	2	
9		65563001	FITTING - 6M O-RING X 6M JIC 45 DEGREE	2	
10		65565001	FITTING - 6M O-RING X 6M JIC ST.	7	
11		59426001	FITTING - 90-6MJ-6MORBA	1	

Oil Cooler Fig 6-14

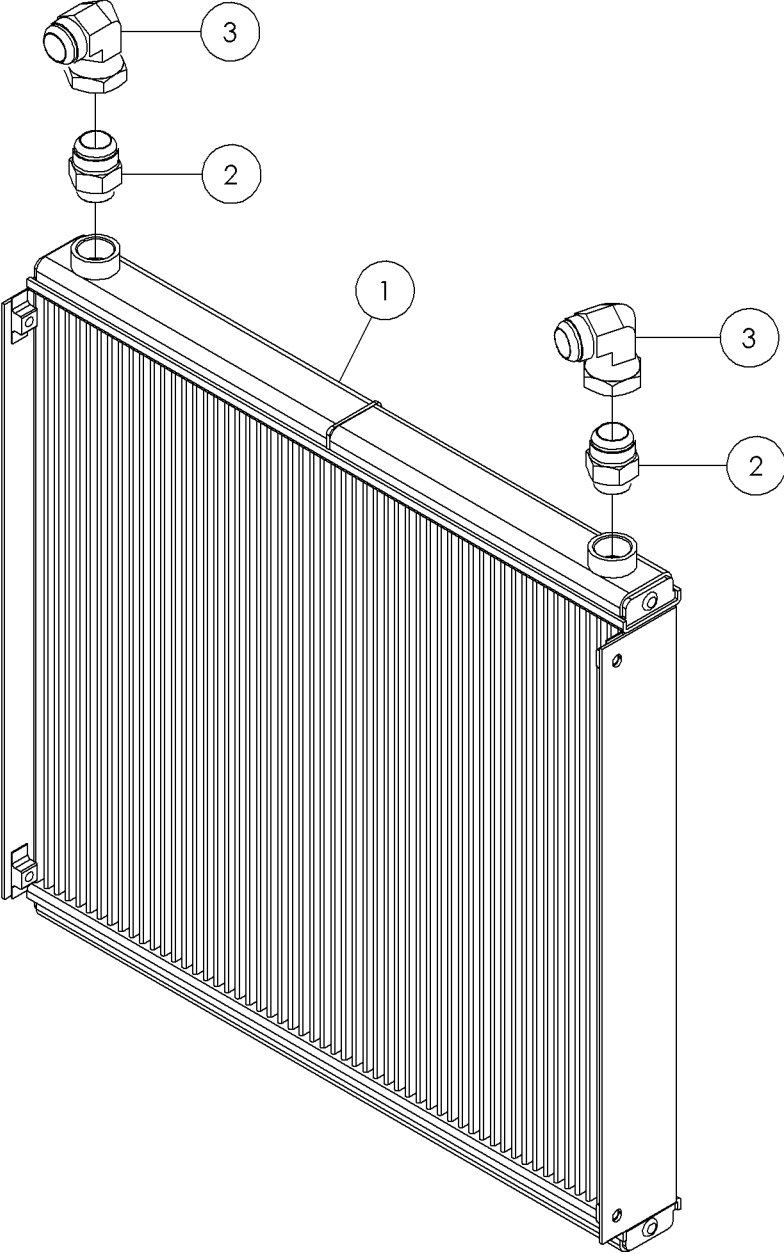
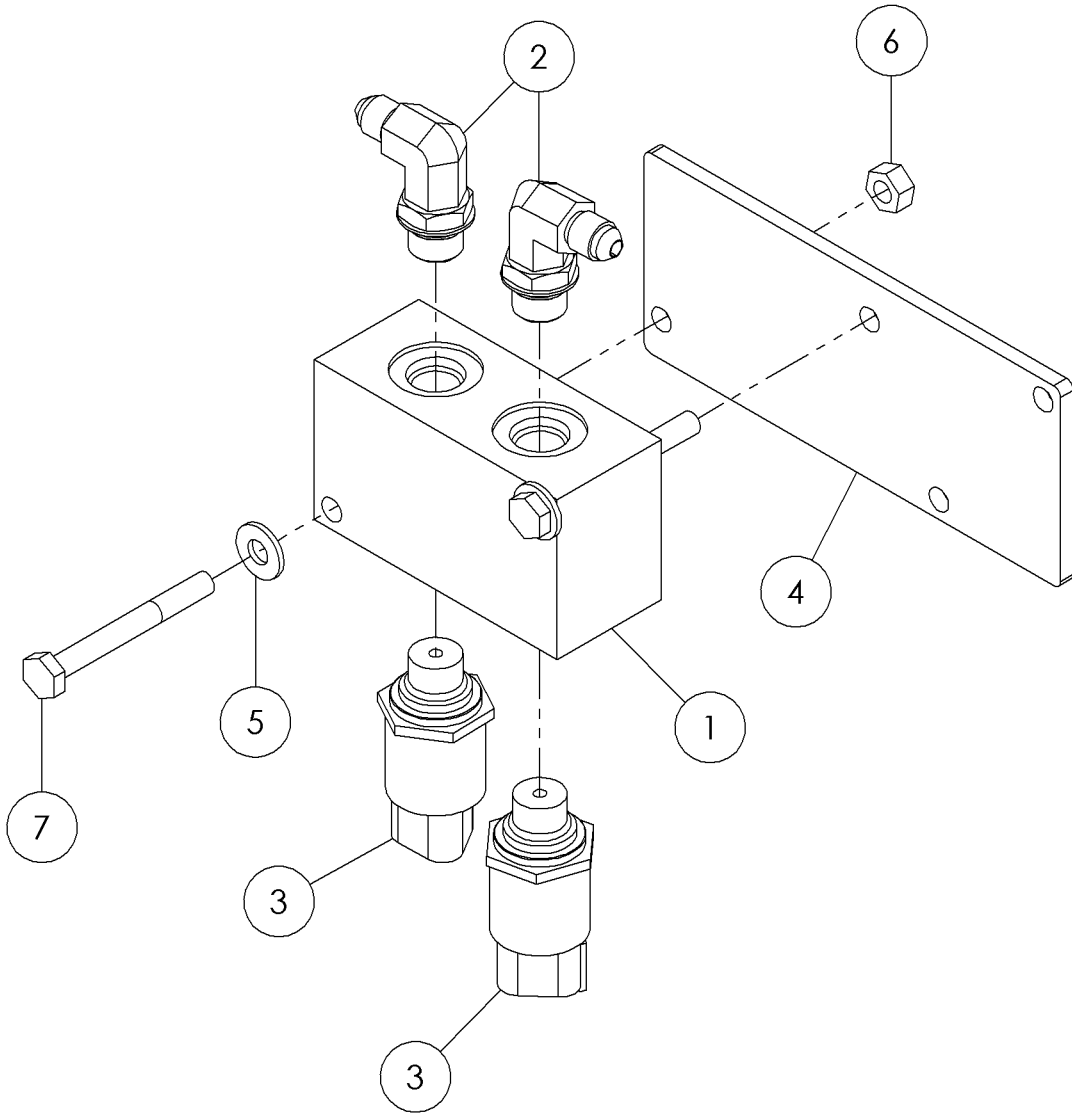

Illustration No. 296279870

## Oil Cooler Fig 6-14

REF. NO.	*	PART NO.	DESCRIPTION	QTY.	REMARKS
1		296279964	COOLER - OIL	1	
2		86320001	FIT-ADAPT 16M ORINGX20MJIC STR	2	
3		65574001	20FS JICX20M JIC 90 DEGREE	2	

Block-Transducer Fig 6-15





## Block-Transducer Fig 6-15

REF. NO.	*	PART NO.	DESCRIPTION	QTY.	REMARKS
1		296282514	MANIFOLD - PRESSURE TRANSDUCER	1	
2		57950001	FITTING-90-4MJ-6MORBA	2	
3		296282516	TRANSDUCER 7500 PSI HYDAC	2	
4		296282517	MOUNT - PRESSURE TRANSDUCER	1	
5		252251001	WASHER-1/4 SAE FLAT ZP	2	
6		235732001	NUT - HEX - .25 - 20 - GR8 - YZ	2	
7		250644001	BOLT-1/4-20 X2 1/4 GR 8 Y/ZINC	2	

Transport Valve 10' Fig 6-16

Illustration No. 296279935

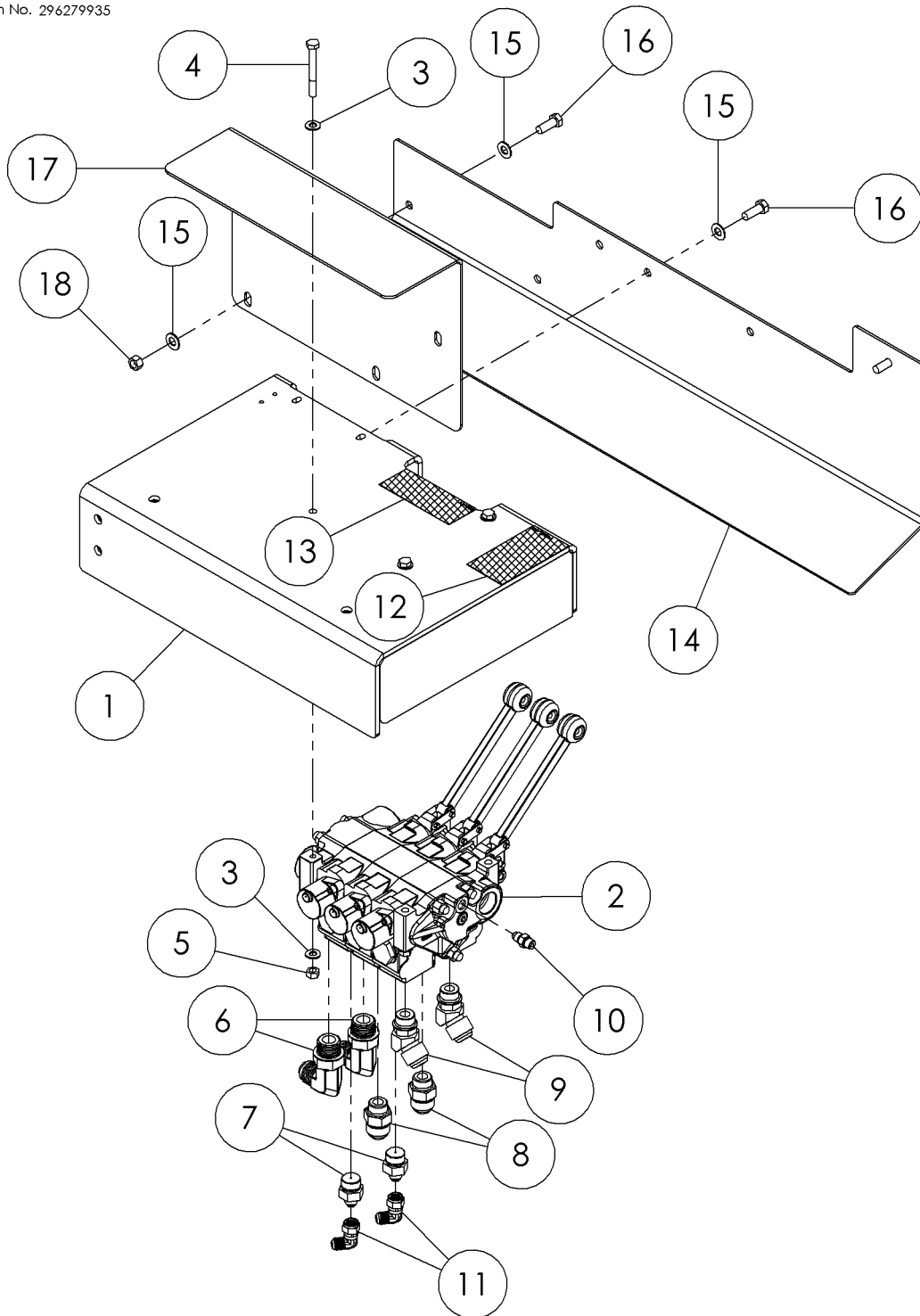

## Transport Valve 10' Fig 6-16

REF. NO.	*	PART NO.	DESCRIPTION	QTY.	REMARKS
1		296303772	WELDMENT - TRANSPORT MOUNT	1	
2		236457001	VALVE-3 SPOOL CONTROL	1	Breakdown Fig. 6-16z01
3		235714001	WASHER-FLATSTRL-.31-.34X.69-.06-YZ-A325	6	
4		250502001	BOLT 5/16-18 X 2 3/4"GR8 HEX Y	3	
5		235741001	NUT - HEX - .31 - 18 - GR8 -YZ	3	
6		278867001	FITTING-12M X 12M JIC LONG 90	2	
7		296269633	FITTING - 10MB - 6MJ ST/R.062	2	
8		60910001	10MX12M JIC ST.ADAPTER	2	
9		67552001	10MX12M JIC 45 DEG.	2	
10		60908001	FITTING-4MX4M JIC STR ADAPTER	1	
11		60851001	FITTING-6M JICX6FS JIC 90ELBOW	2	
12		7000C446	DECAL - NO WELD	1	Domestic
12		700IC446	DECAL - NO WELD	1	International
13		700IA472	DECAL-CTRL. TRACK & RACK (UG)	1	
14		296269702	PLATE - SHIELD TRANSPORT D36X50II	1	
15		235713001	WASHER-FLATSTRL-.38-.41X.81-.06-YA-A325	7	
16		235727001	SCREW-HCS-.38-16X1.00-GR8-YZ	5	
17		296269703	PLATE - SHIELD TRANSPORT	1	
18		163621963	NUT-HEXCTRLOCK-.38-16-GR5-YZ	2	

Components-Control Valve Fig 6-16z01

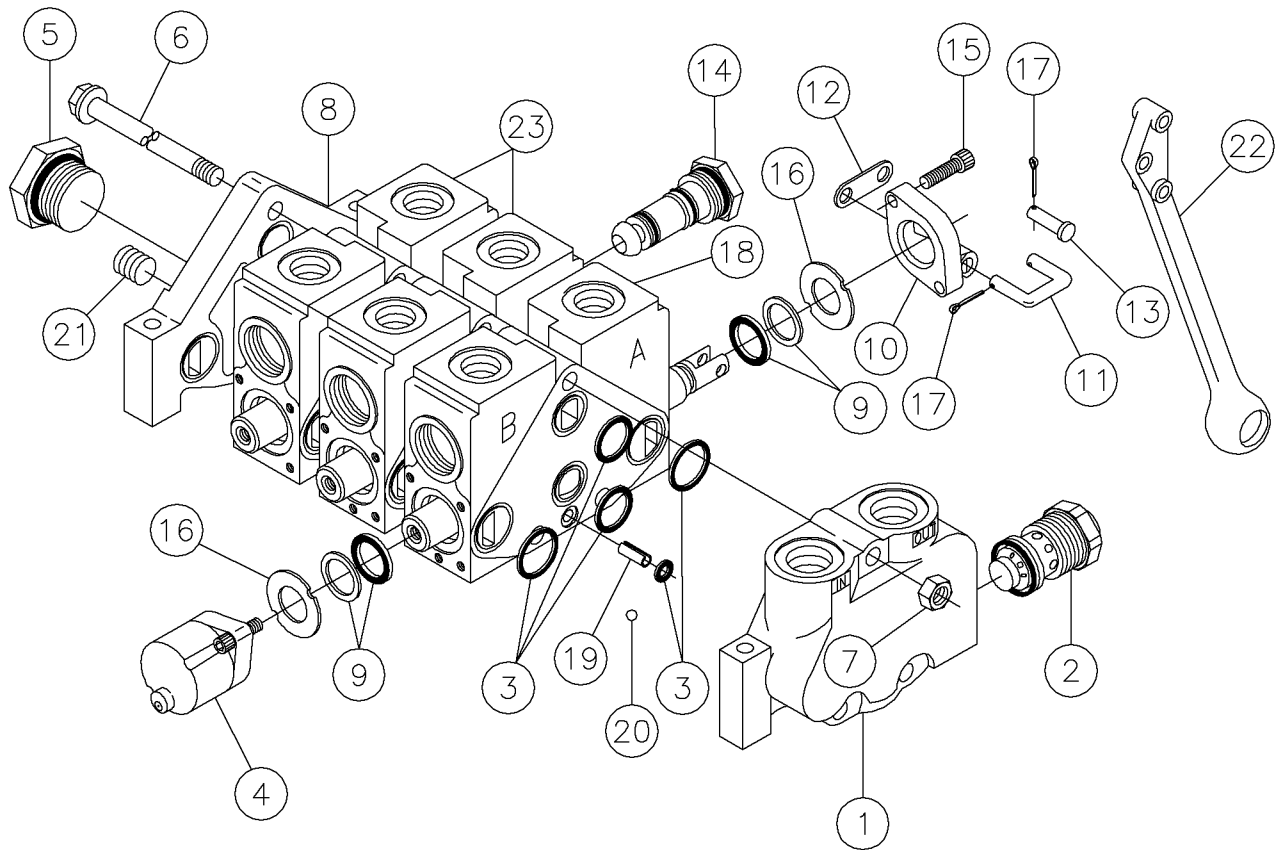

## Components-Control Valve Fig 6-16z01

REF. NO.	*	PART NO.	DESCRIPTION	QTY.	REMARKS
1		228113003	LEFT COVER PLATE COMPLETE	1	Inc Ref No 2
2		228113005	WH MAIN RELIEF (3500 PSI)	1	Breakdown Fig. 6-16z02
3		87390001	REPAIR KIT-LOAD SENSING SECT.	4	
4		6149005	POSITIONER-STD. GRESEN K-6125	3	Breakdown Fig. 6-16z03
5		3152011	PLUG SAE 12 GRESEN 1726-001	1	Include O-Ring
		3152013	SEAL-O-RING GRESEN 2708-001	1	
6		16358005	STUD KIT-3 SPOOL K-6106	1	Inc. Ref. No 7
7		446001	NUT-3/8 NF HEX	3	
8		102976001	COVER ASSY-RIGHT LOAD SEN.	1	Inc. One Of Ref. 3, 5 & 21
9		3147077	REPAIR KIT GRESEN K-6035	3	
10		3147029	BRACKET GRESEN 1801-001	3	
11		4333003	LINK-	3	
12		4333005	PLATE-LINK	3	
13		2110003	PIN - CLEVIS 1/4 X 7/8 - 47/64 UL ZINC	3	
14		3147035	PLUG-LOAD CHECK STEEL K-6030	6	Breakdown Fig. 6-16z04
15		79704001	SCREW-1/4-20X7/8 SOC HD SELFLK	6	
16		3147081	RETAIN-PLT WASH GRN 6752-001	6	
17		510035	PIN-3/32 X 1/2 COTTER	9	
18		224397003	BODY ASSEMBLY-CENTER SECTION	1	Inc. One Of Ref's 3, 4, 9-11, 13, 19, 20 & 22, Inc. Two Of Ref's 14-16 & Inc.Three Ref. 17
19		87397001	PIN-SPRING	1	
20		87398001	BALL	1	
21		3213017	PLUG-RELIEF 3/8" GRESEN 73-001	1	
22		280625001	HANDLE-W/ ZINC PLATE & BLACK PLASTIC COAT	3	
23		236457003	BODY ASSY-CNTR SEC W/FREE FLOW	2	Inc. One Of Ref's 3, 4, 9-11, 13, 19, 20 & 22, Inc. Two Of Ref's 14-16 & Inc.Three Ref. 17
		236457001	VALVE-3 SPOOL CONTROL		Includes All Items In Figure

Components-WH Main Relief Fig 6-16z02

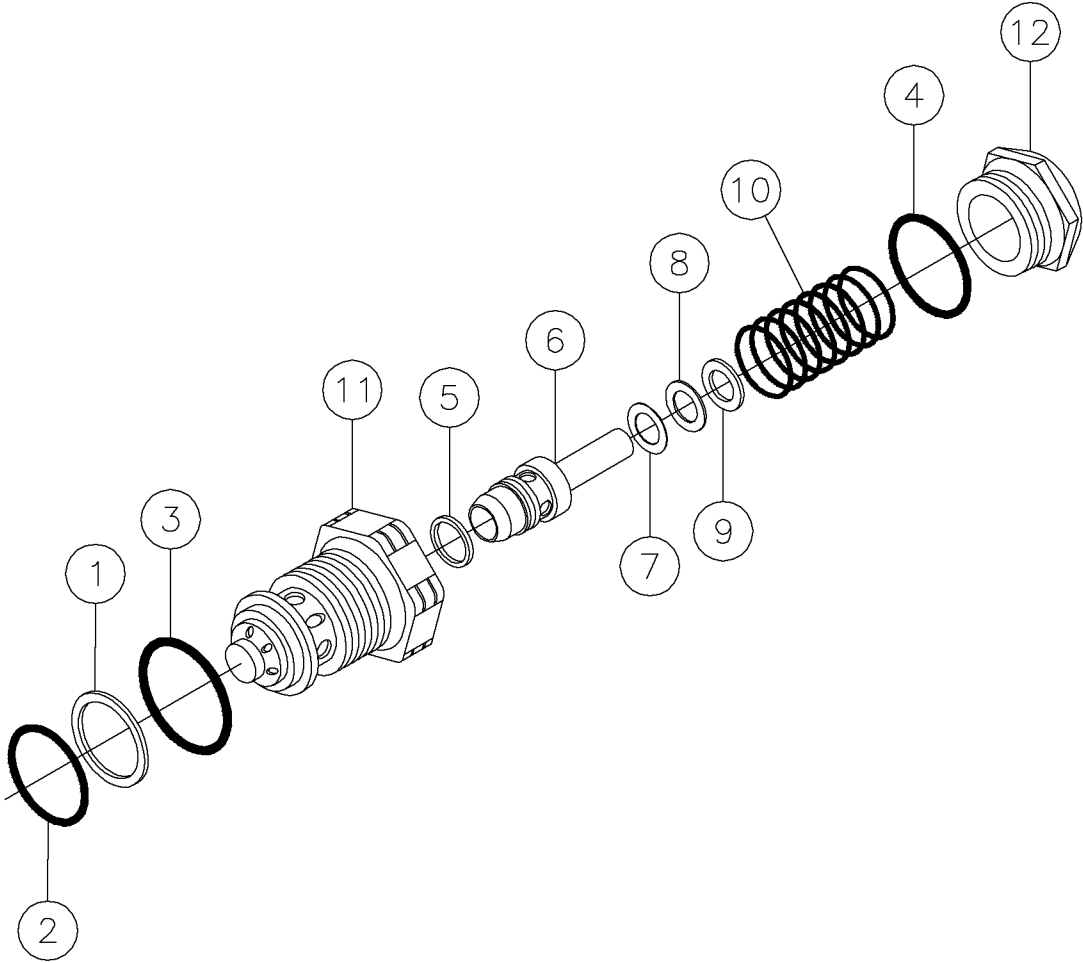

## Components-WH Main Relief Fig 6-16z02

REF. NO.	*	PART NO.	DESCRIPTION	QTY.	REMARKS
1			RING - BACKUP	1	Not Sold Separately
2			SEAL - O - RING	1	Not Sold Separately
3			SEAL - O - RING	1	Not Sold Separately
4			BODY-WH RELIEF	1	Not Sold Separately
5			RING - PISTION	1	Not Sold Separately
6			POPPET	1	Not Sold Separately
7		208019	SHIM - .010 #0462-001	A/R	
8		208017	SHIM - .020 #0459-001	A/R	
9		208015	SHIM - .040 #0458-001	A/R	
10		228113007	SPRING (3000-3500 PSI)	1	
11		15844009	BODY-WH RELIEF 6533-001	1	
12		3147027	CAP GRESEN 1880-001	1	
		15844007	REPAIR KIT-K19003		Included Ref's 1, 3 & 11
		3147011	SERVICE KIT GRESEN K-19002		Included Ref's 5 & 6
		228113005	WH MAIN RELIEF (3500 PSI)		Inc. All Items In This Figure.

Components-Standard Spool Positioner Fig 6-16z03

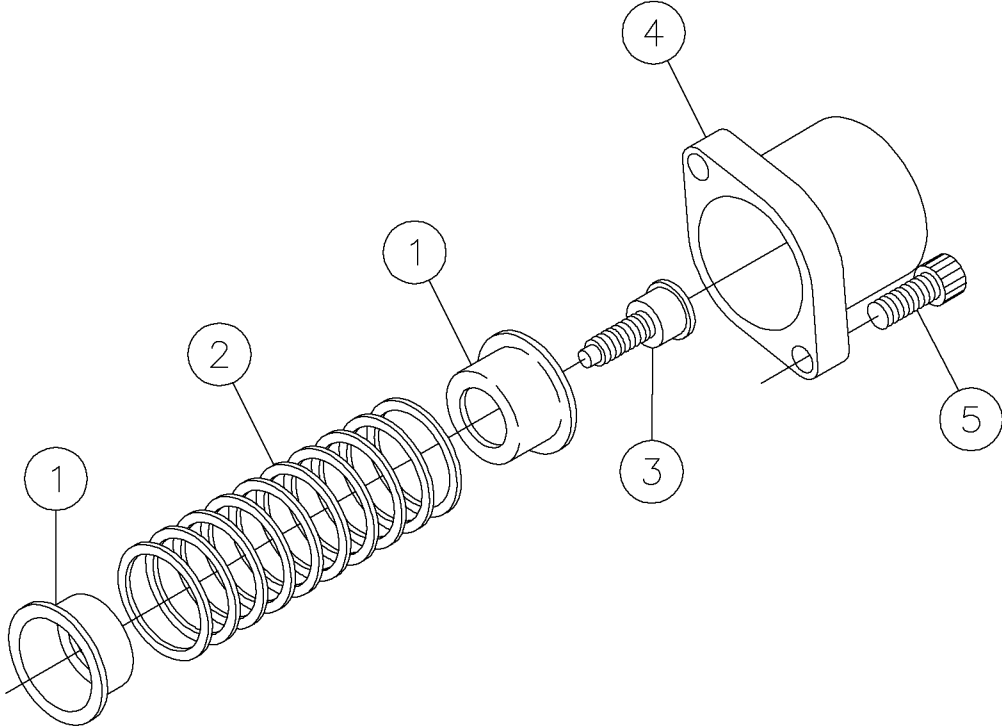



## Components-Standard Spool Positioner Fig 6-16z03

REF. NO.	*	PART NO.	DESCRIPTION	QTY.	REMARKS
1		3149005	COLLAR-SPRING GRESEN 1809-001	2	
2		6149057	SPRING-RETURN 7433-001	1	
3		3149013	COLLAR-SPOOL	1	
4		6149043	BONNET	1	
5		79704001	SCREW-1/4-20X7/8 SOC HD SELFLK	2	
		6149005	POSITIONER-STD. GRESEN K-6125		Inc. All Items In This Figure.

Components-Load Check Plug Fig 6-16z04

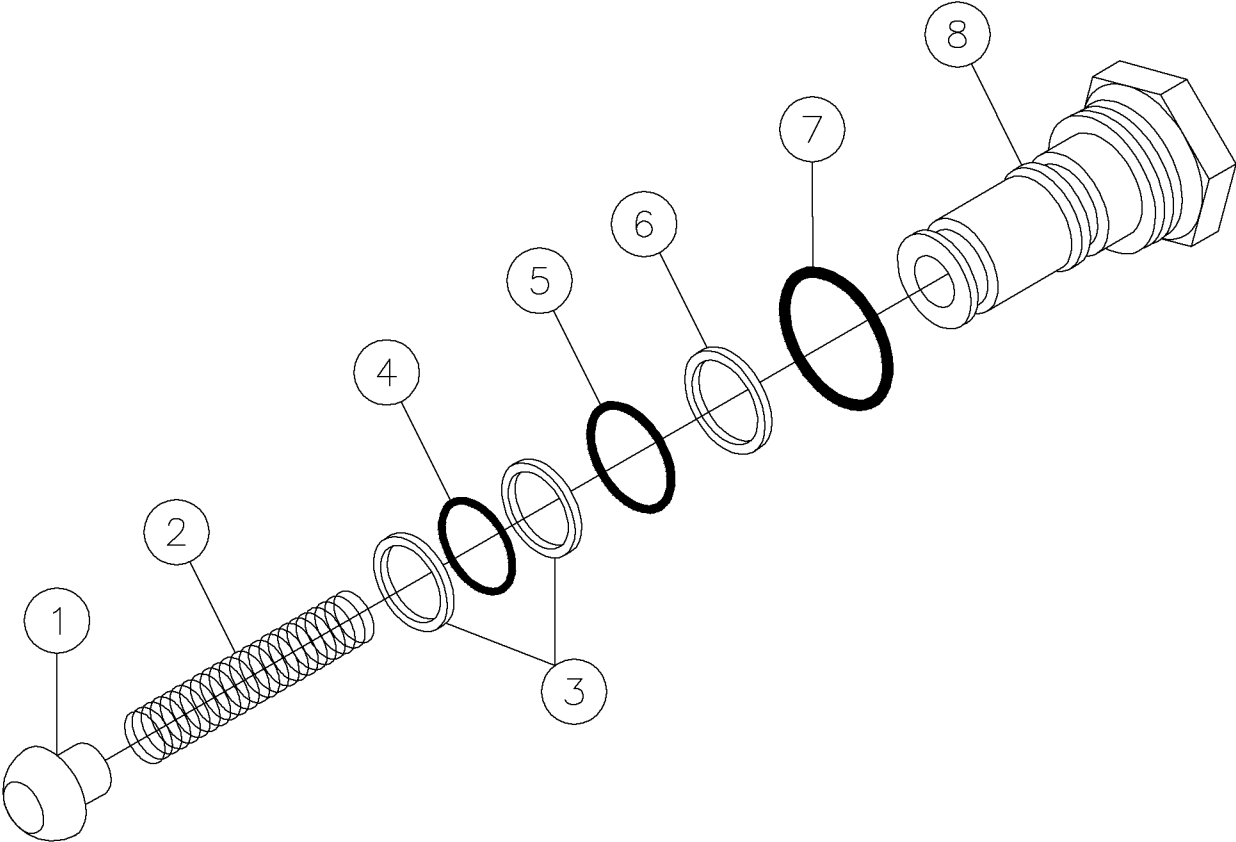

## Components-Load Check Plug Fig 6-16z04

REF. NO.	*	PART NO.	DESCRIPTION	QTY.	REMARKS
1		3128009	POPPET-CHECK GRESEN 2781-001	1	
1		3149005	COLLAR-SPRING GRESEN 1809-001	2	
2		3147041	SPRING-CHECK GRESEN 1868-001	1	
2		6149057	SPRING-RETURN 7433-001	1	
3		3149013	COLLAR-SPOOL	1	
3			WASHER - BACKUP (INNER)	2	Not Sold Separately
4			O - RING	1	Not Sold Separately
4		6149043	BONNET	1	
5		79704001	SCREW-1/4-20X7/8 SOC HD SELFLK	2	
5			O - RING	1	Not Sold Separately
6			WASHER - BACKUP (INNER)	1	Not Sold Separately
7			PLUG-LIFT CHECK	1	Not Sold Separately
8		3147043	PLUG-LIFT CHECK GRSN 3411-001	1	
		3147037	REPAIR KIT GRESEN K-6032		Inc. Ref's 3-7
		3147035	PLUG-LOAD CHECK STEEL K-6030		Inc. Ref's 1-8

Valve-Counter Balance Fig 6-17

Illustration No. 296303809

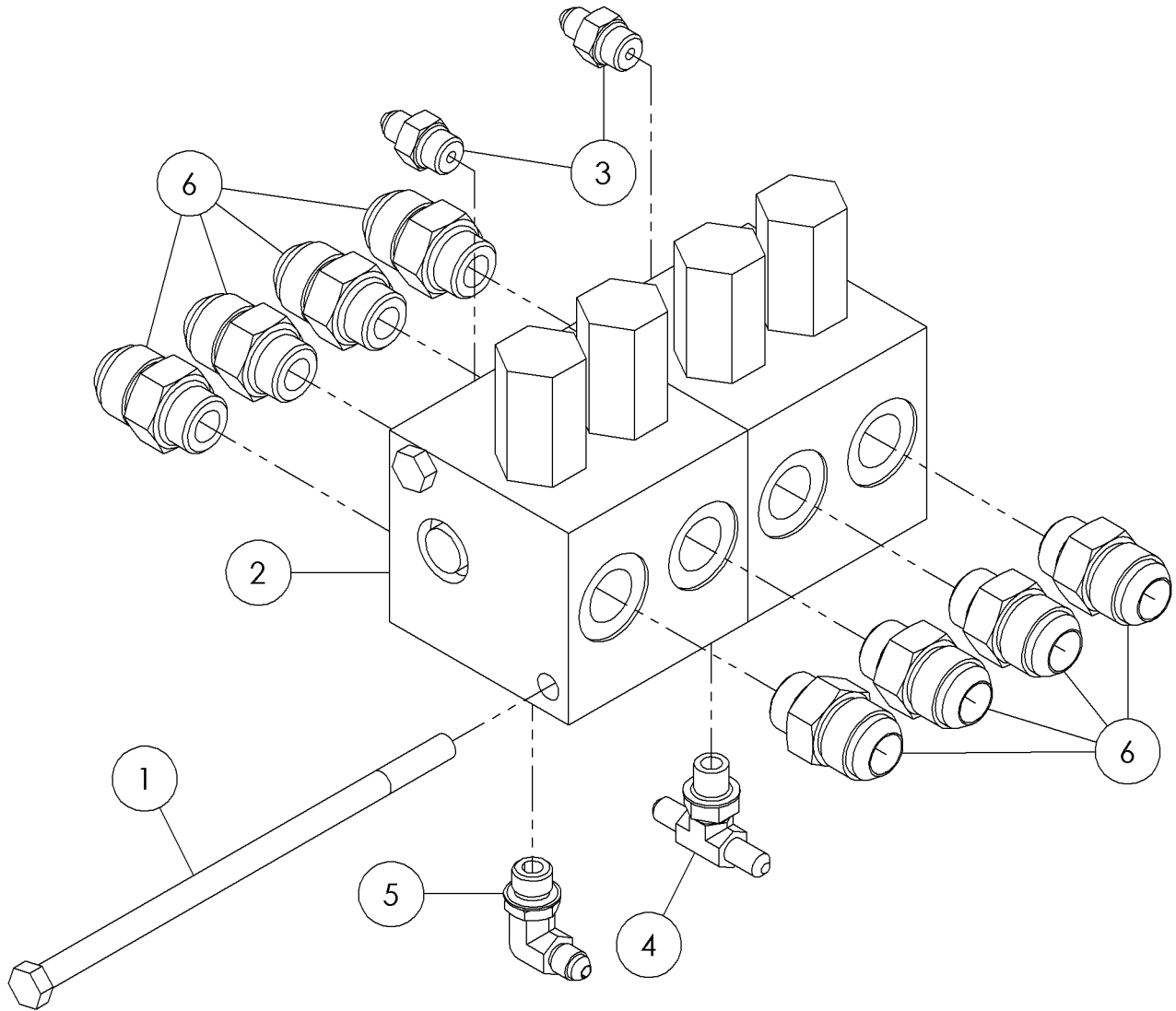

## Valve-Counter Balance Fig 6-17

REF. NO.	*	PART NO.	DESCRIPTION	QTY.	REMARKS
1		510302080	SCREW-HCS-.38-16X8.00-GR5-YZ	2	
2		296303800	VALVE-DUAL OPERATED COUNTER BALANCE	2	Breakdown Fig. 6-17z01
3		57968001	FITTING-STR-4MJ-6MORB	2	
4		163644603	FITTING-BTEE-4MJ-4MJ-6MORBA	1	
5		57950001	FITTING - 90-6MORBA-4MJ	1	
6		60910001	10MX12M JIC ST.ADAPTER	8	

Components-Valve Counter Balance Fig 6-17z01

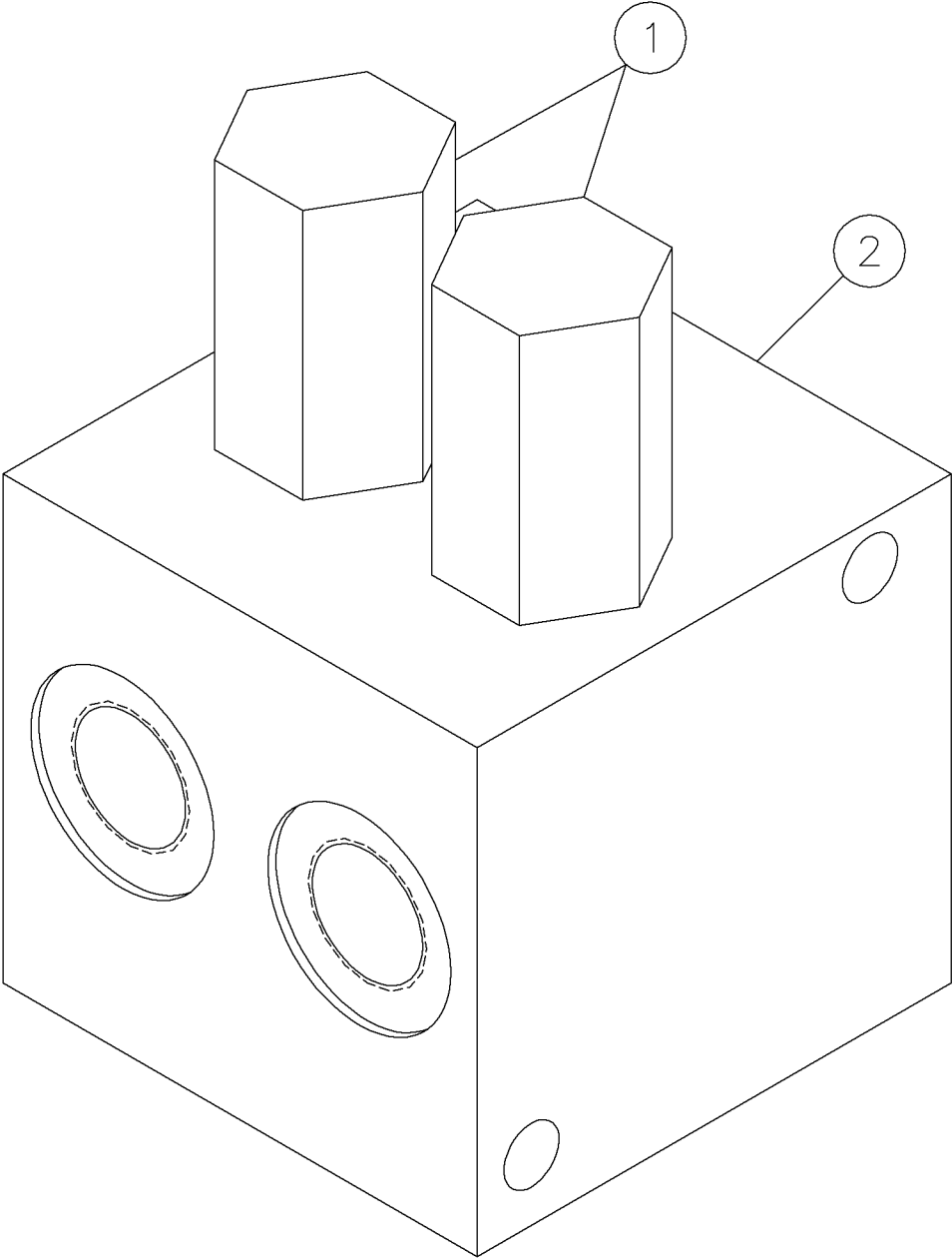

## Components-Valve Counter Balance Fig 6-17z01

REF. NO.	*	PART NO.	DESCRIPTION	QTY.	REMARKS
1		296319508	Check Valve	2	
2			Body Valve	1	Not Sold Separately
		296303800	VALVE-DUAL OPERATED COUNTER BALANCE		
		296319507	Seal Kit		

Vise Clamp Fig 7-1

Illustration No. 296279887

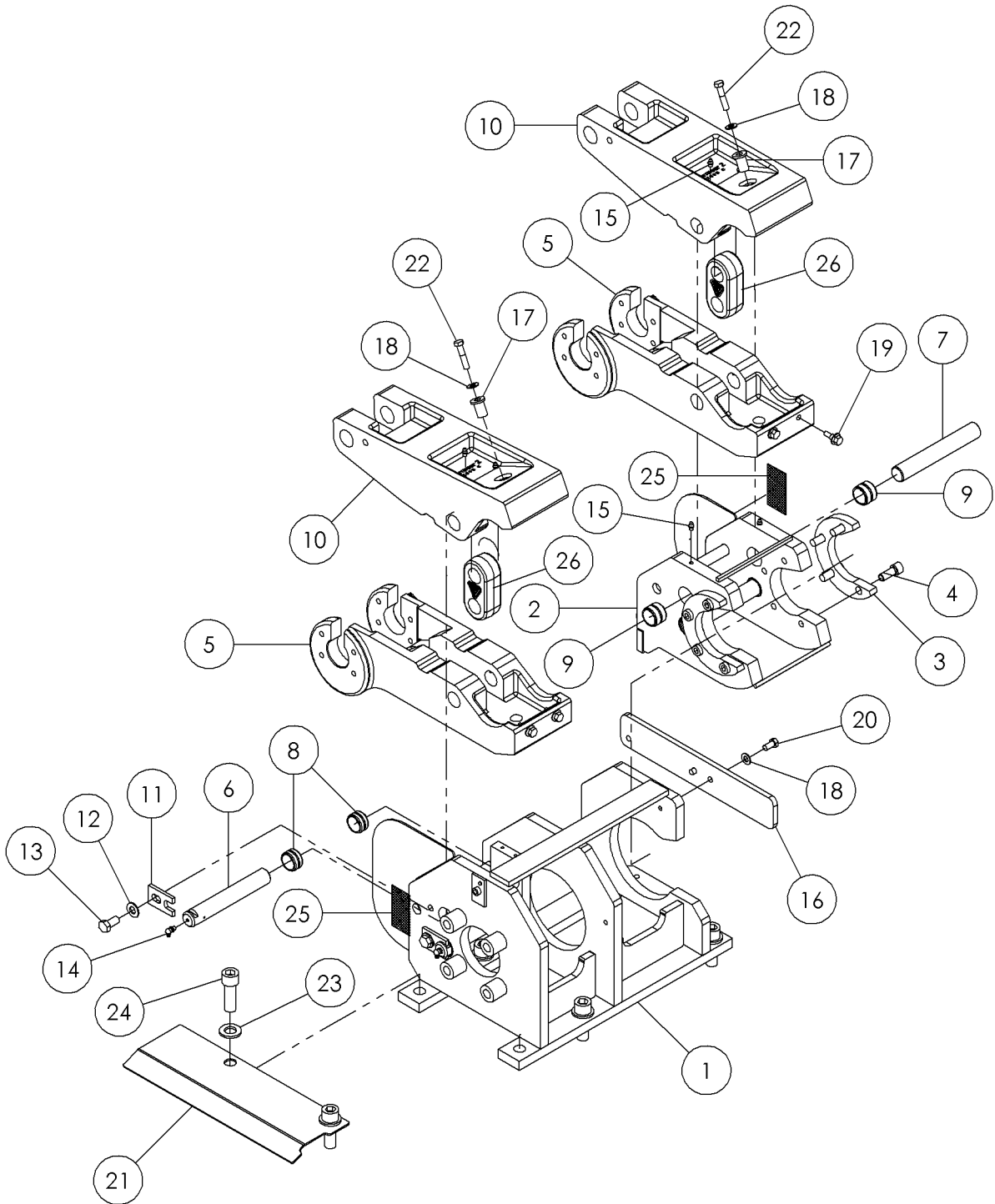



## Vise Clamp Fig 7-1

REF. NO.	*	PART NO.	DESCRIPTION	QTY.	REMARKS
1		243025001	FRAME-VISE	1	
2		240885001	PIVOT VISE - DUPLICATE FIXTURE	1	
3		240908001	PLATE-INSERT	2	
4		240854001	SCREW-1/2-13 UNCX1 1/4 LOW SH	8	
5		282810001	VISE - LOWER ARM	2	
6		240909001	PIN-VISE	2	
7		240918001	PIN-PIVOT	2	
8		240878001	BSHG-STL 1 3/8 ODX1 1/8 ID-.75	4	
9		240877001	BSHG-STL 1 3/8 ODX1 1/8 ID-1.0	4	
10		282811001	ARM - JAW UPPER VISE	2	
11		235929001	PLATE-TAB	2	
12		485025	WASHER-1/2 FLAT-HARDENED-YZ	2	
13		235729001	SCREW-HCS-.50-13X1.00-GR8-YZ	2	
14		597001	ZERK-1/4" NF 90 DEG GREASE ZYC	2	
15		598001	FITTING-1/4" NF ST GREASE ZERK	12	
16		296303151	BAR - ROD GUIDE	1	
17		228064001	*INSERT-FASTENER	2	
18		235713001	*WASHER - FLATSTRL - .38 - .41 X .81 - .06-YA-A325	4	
19		249161001	BOLT-JAW PIN 3/8-16 X 1 SP PER PRINT	4	
20		235726001	BOLT-3/8-16X3/4 GR8 HEX ZNCPLT	2	
21		291538001	PLATE-FRONT VICE	1	
22		235720001	*BOLT-3/8-16X1 3/4 6R8 ZINC PLT	2	
23		235717001	WASHER - 3/4" HARDENED FLAT YZ	6	
24		249153001	SCREW-3/4-10X2 1/4 GR8 Y/ZINC	6	
25		7000A864	DECAL-WARNING DOMESTIC	2	Domestic
25		700IA864	DECAL - WARNING INTERNATIONAL	2	International
26		296315287	LINK PLATE	2	

Cylinder-Jaw Fig 7-2

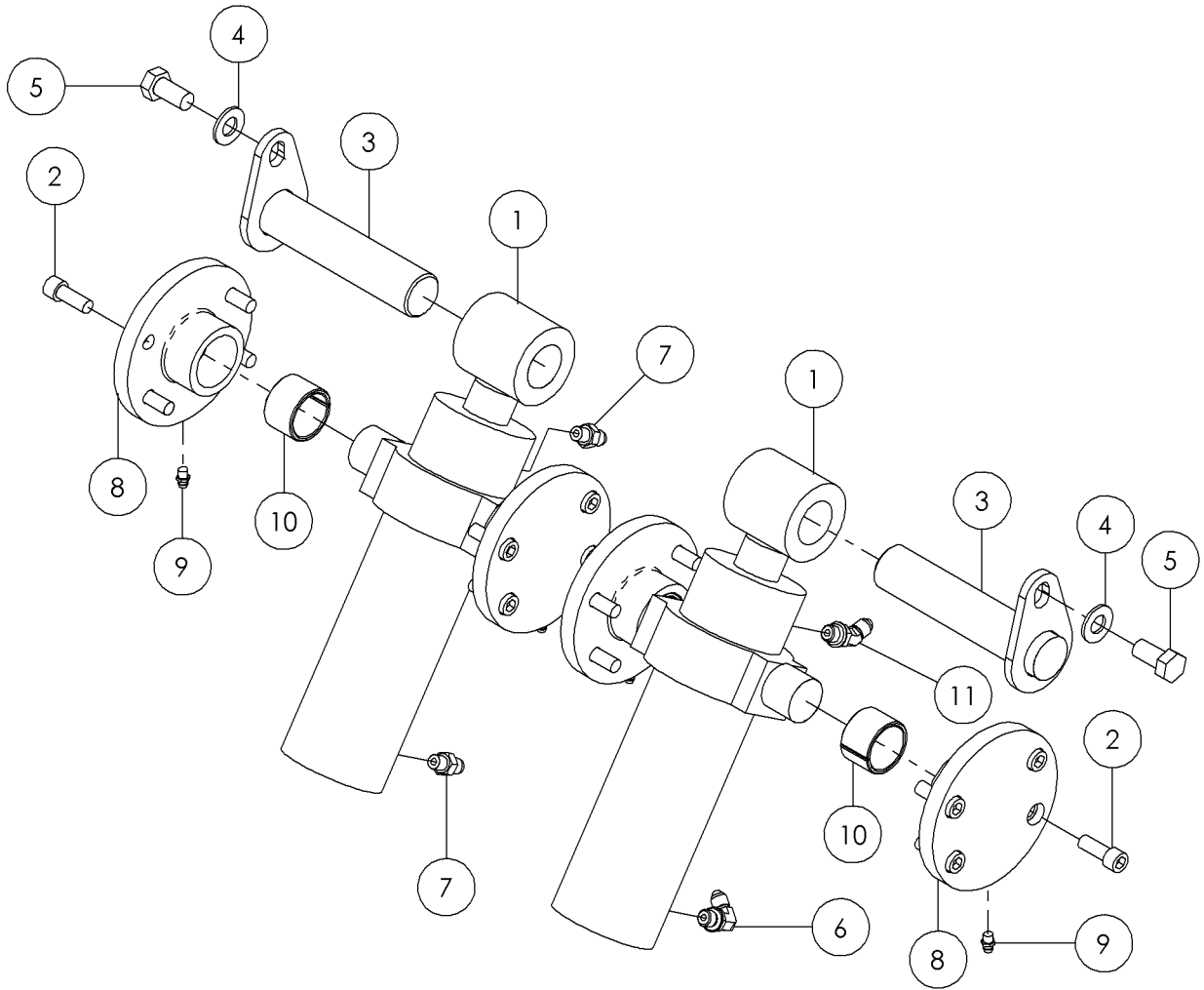

## Cylinder-Jaw Fig 7-2

REF. NO.	*	PART NO.	DESCRIPTION	QTY.	REMARKS
1		296285660	CYLINDER - 2-1/2 X 6-5/8	2	Breakdown Fig. 7-2z01
2		601696010	SOCKET HD CAP SCREW 3/8-16X1 Z	16	
3		228058001	PIN-CLAMP	2	
4		485025	WASHER-1/2 FLAT-HARDENED-YZ	2	
5		235729001	SCREW-HCS-.50-13X1.00-GR8-YZ	2	
6		59423001	FIT-4M JICX4M ADJ.90 DEG.ELBOW	1	
7		60908001	FITTING-4MX4M JIC STR ADAPTER	2	
8		240888001	BOSS-TRUNION	4	
9		598001	FITTING-1/4" NF ST GREASE ZERK	4	
10		1835025	BSHG.-STL.- 1 1/2 X 1 1/4 X 1	4	
11		58295001	FITTING-4M OR X 4M JIC 45 DEG.	1	

Components-Cylinder Jaw Fig 7-2z01

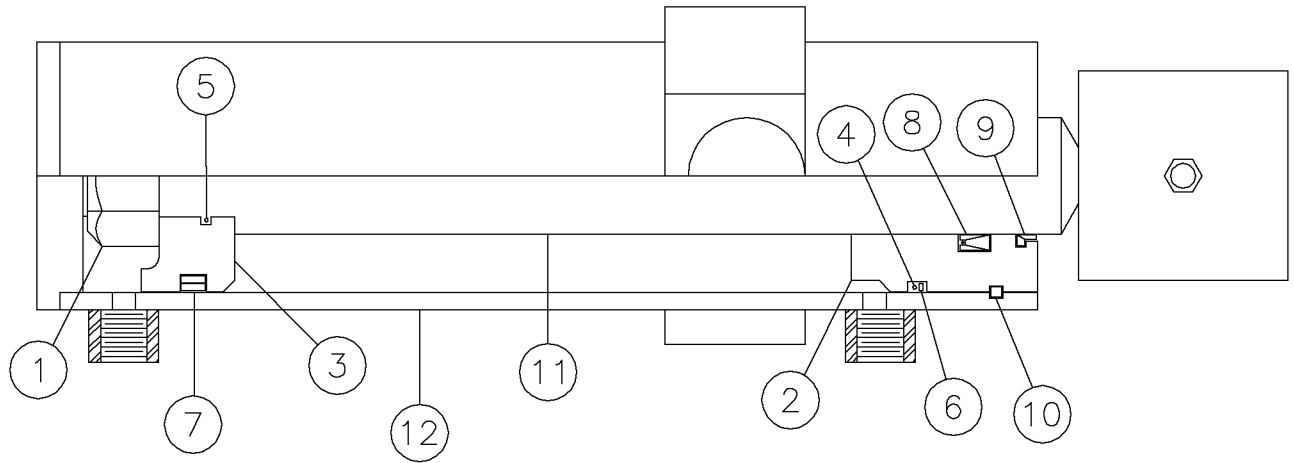

## Components-Cylinder Jaw Fig 7-2z01

REF. NO.	*	PART NO.	DESCRIPTION	QTY.	REMARKS
1			NUT	1	
2			HEAD	1	
3			PISTON	1	
4			O-RING	1	Not Sold Separately
5			O-RING	1	Not Sold Separately
6			BACKUP	1	Not Sold Separately
7			PSP-SEAL	1	Not Sold Separately
8			POLYPAK	1	Not Sold Separately
9			DUST SEAL	1	Not Sold Separately
10			RETAINING RING	1	
11		296285214	SHAFT W/CLEVIS	1	
12			BARREL W/ TRUNNION & PORTS	1	
		296285660	CYLINDER-2 1/2" X 6 5/8"		Inc. all Items In Figure
		296285215	SEAL KIT		Included Ref. 4 Thru 9

Cylinder-Rotation Fig 7-3

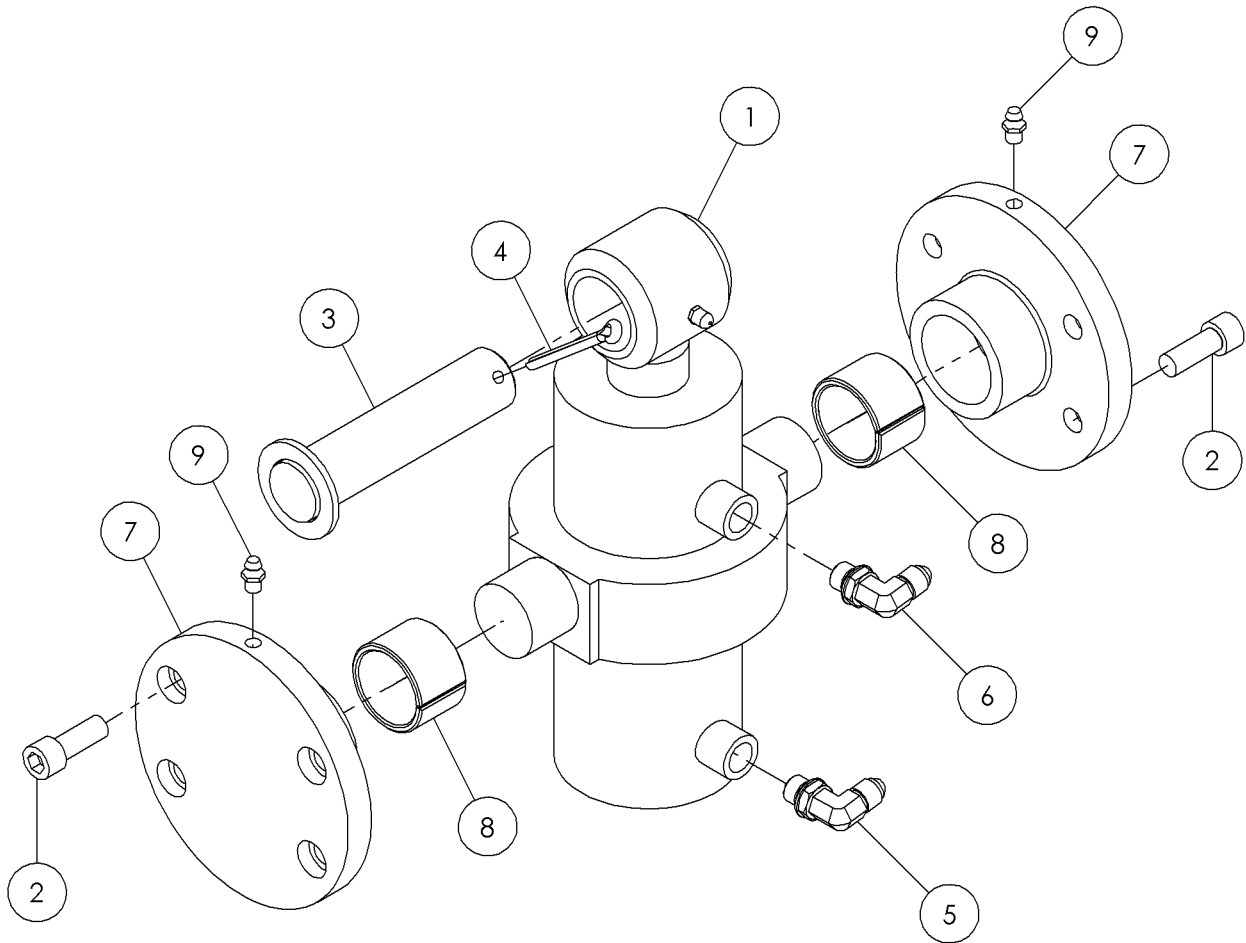
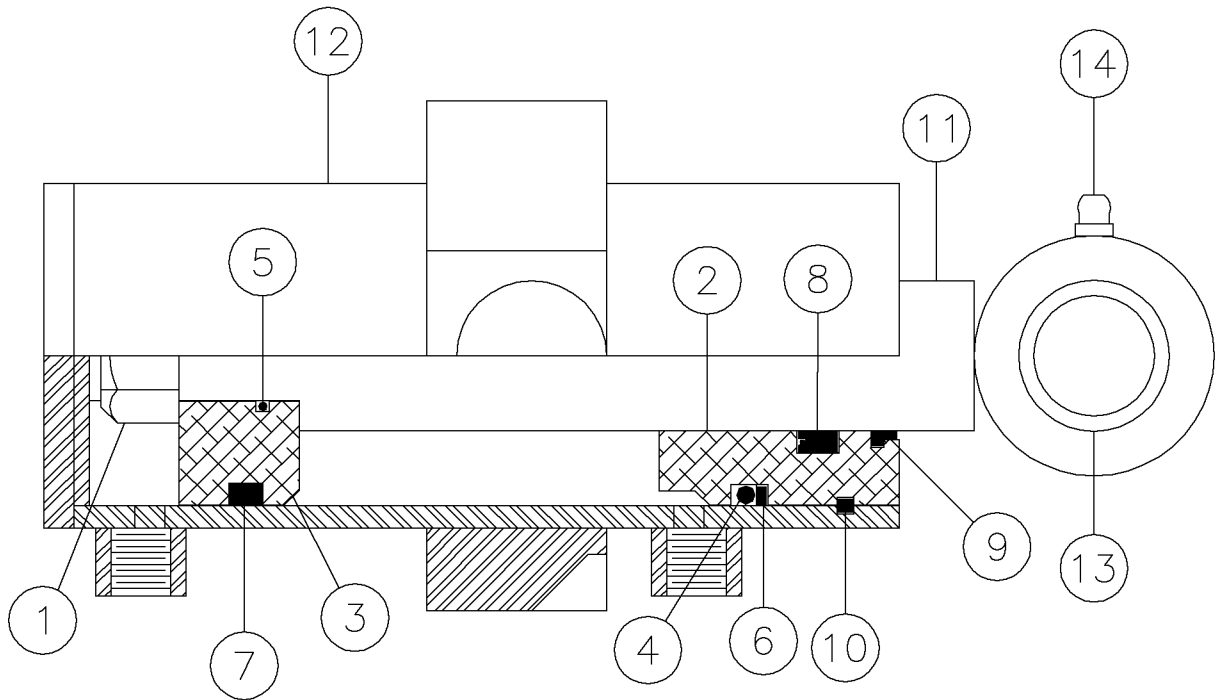

Illustration No. 296279889

## Cylinder-Rotation Fig 7-3

REF. NO.	*	PART NO.	DESCRIPTION	QTY.	REMARKS
1		276260001	CYLINDER-2 1/2 X 3 3000 PSI	1	Breakdown Fig. 7-3z01
2		601696010	SOCKET HD CAP SCREW 3/8-16X1 Z	8	
3		228061001	PIN-TILT	1	
4		510025	COTTER PIN-3/16" X 2"	1	
5		59423001	FIT-4M JICX4M ADJ.90 DEG.ELBOW	1	
6		279290001	FITTING-4MORX4MJIC 90DEG R.060	1	
7		240888001	BOSS-TRUNION	2	
8		1835025	BSHG.-STL.- 1 1/2 X 1 1/4 X 1	2	
9		598001	FITTING-1/4" NF ST GREASE ZERK	2	

Components-Cylinder Rotation Fig 7-3z01





## Components-Cylinder Rotation Fig 7-3z01

REF. NO.	*	PART NO.	DESCRIPTION	QTY.	REMARKS
1		241830003	NUT	1	
2		276260003	HEAD	1	
3		228165017	PISTON	1	
4		228165007	O-RING	1	
5		228165005	O-RING	1	
6		228165009	WASHER-BACK UP	1	
7		228165003	PSP SEAL	1	
8		228165013	POLYPAK SEAL	1	
9		228165015	DUST SEAL	1	
10		228165011	RING-RETAINING	1	
11		276260005	ROD - CYLINDER	1	Inc. One Of Ref. 14 & Two Of Ref. 13
12		276260007	BODY - CYLINDER	1	
13		1835015	BSHG.-STL.-1 1/4 X 1 X 1	1	
14		598001	FITTING-1/4" NF ST GREASE ZERK	1	
		276260001	CYLINDER-2 1/2 X 3 3000 PSI		Includes All Items In Figure
		228165023	SEAL KIT		

Valve-Vise Clamp Fig 7-4

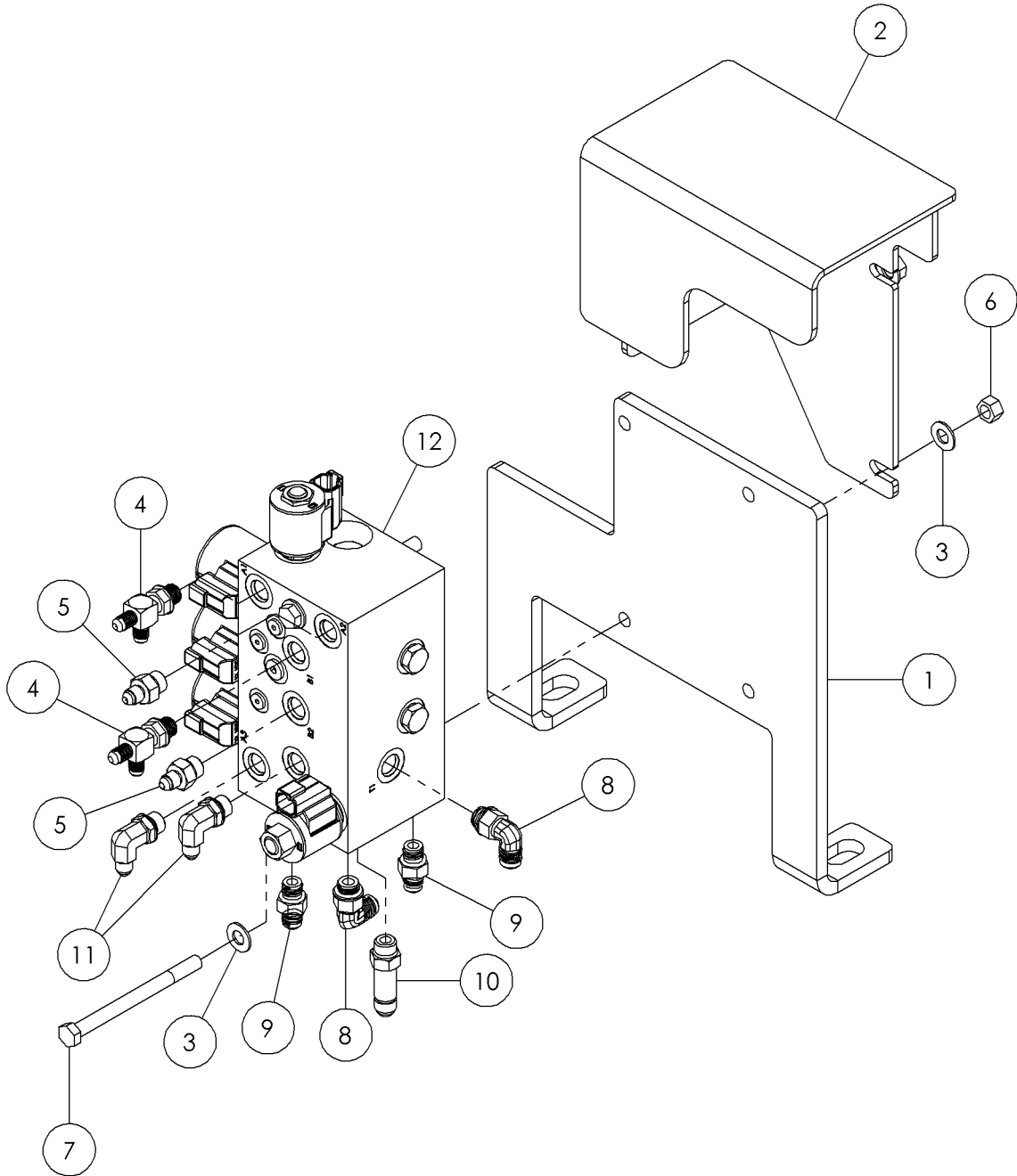
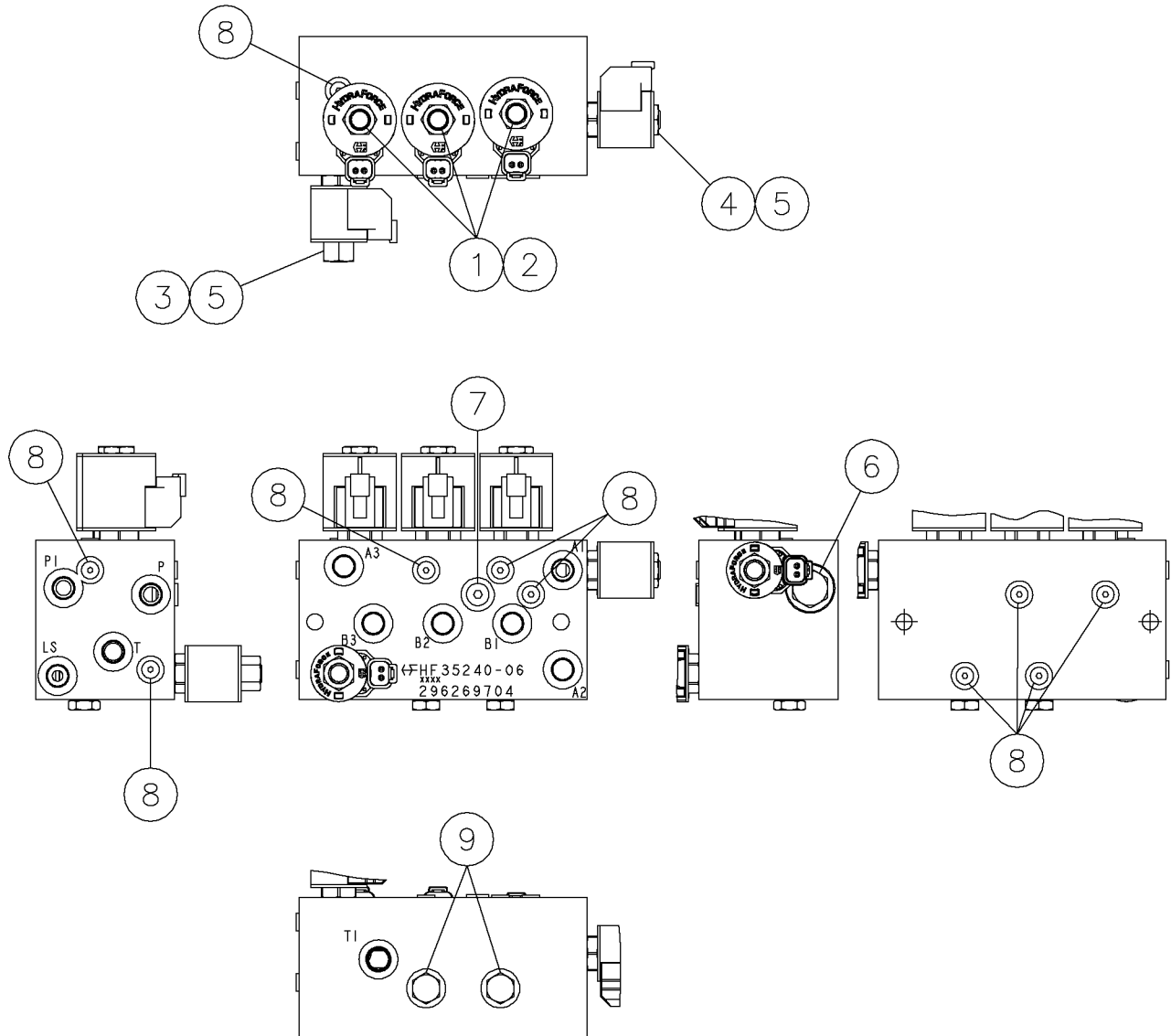

Illustration No. 296279925

## Valve-Vise Clamp Fig 7-4

REF. NO.	*	PART NO.	DESCRIPTION	QTY.	REMARKS
1		296292083	ANGLE - VISE VALVE MOUNT	1	
2		296292080	WELDMENT - VICE VALVE COVER	1	
3		235713001	WASHER-FLATSTRL-.38-.41X.81-.06-YA-A325	4	
4		82930001	FIT-6MX4M JICX4M JIC (RUN) TEE	2	
5		57968001	FITTING-STR-4MJ-6MORB	2	
6		250508001	NUT - 3/8-NC Gr8 TOP LOCK Y/ZINC	2	
7		238246001	BOLT 3/8"-16 X 4 1/2" GR8 HEX	2	
8		59426001	FITTING - 90-6MJ-6MORBA	2	
9		65565001	FITTING - 6M O-RING X 6M JIC ST.	2	
10		103047001	FITTING-6MJICX6MORING LONG STR	1	
11		57950001	FITTING-90-4MJ-6MORBA	2	
12		296269704	VISE - VALVE	1	Breakdown Fig. 7-4z01

Components-Valve Vise Clamp Fig 7-4z01



## Components-Valve Vise Clamp Fig 7-4z01

REF. NO.	*	PART NO.	DESCRIPTION	QTY.	REMARKS
1		296265596	CARTRIDGE - SOLENOID VALVE	3	
		296265599	SEAL KIT		
2		296271077	COILS	3	
3		296285227	CARTRIDGE	1	
		296265595	SEAL KIT		
4		296265600	CARTRIDGE - SOLENOID VALVE	1	
		296265595	SEAL KIT		
5		296271115	COIL	2	
6		296276878	CHECK VALVE	1	
		296265595	SEAL KIT		
7		240324011	PLUG-SAE	1	
8		240324015	PLUG-SAE	10	
9		228128013	SENSE CHECK	2	
		296269704	WISE - VALVE		Includes All Items In Figure

Strike Alert (S/N 568-) Fig 7-5r01

Illustration No. 296303234

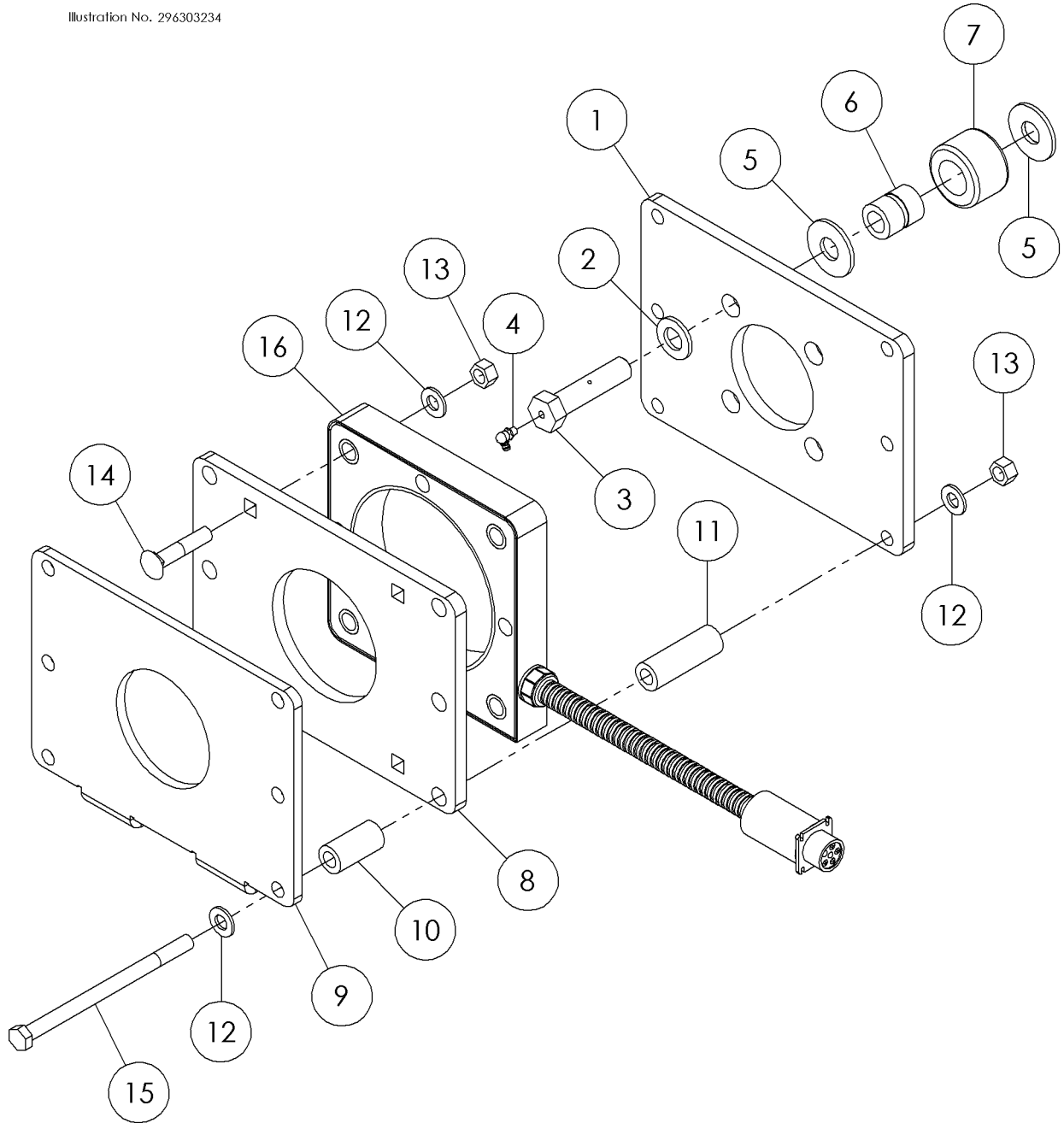

## Strike Alert (S/N 568-) Fig 7-5r01

REF. NO.	*	PART NO.	DESCRIPTION	QTY.	REMARKS
1		296303235	PLATE- ROLLER SUPPORT	1	
2		235717001	WASHER - 3/4" HARDENED FLAT YZ	4	
3		235915001	BOLT-GREASABLE ROLLER 26184	4	
4		597001	ZERK-1/4" NF 90 DEG GREASE ZYC	4	
5		485017	WASHER-3/4 FLAT	8	
6		244678001	BUSHING GUIDE ROLLER	4	
7		296310860	ROLLER - GUIDE	4	
8		296303236	PLATE - WIPER GUIDE	1	
9		296303237	PLATE - WIPER	1	
10		296303238	TUBE - SPACER	6	
11		296285581	TUBE - SPACER	6	
12		235712001	WASHER-1/2 SAE HARD ZINC PLTD	16	
13		235731001	NUT-1/2-13 GR8 ZYC	10	
14		377024	1/2-13X2 1/2"GD#5CARRIAGE BOLT	4	
15		249812001	BOLT-1/2-13X7 1/2 HHCS GR8 ZYC	6	
16		296330529	STRIKE ALERT COIL 6" VERMEER W/ HD CON	1	

Strike Alert (S/N 552-567) Fig 7-5

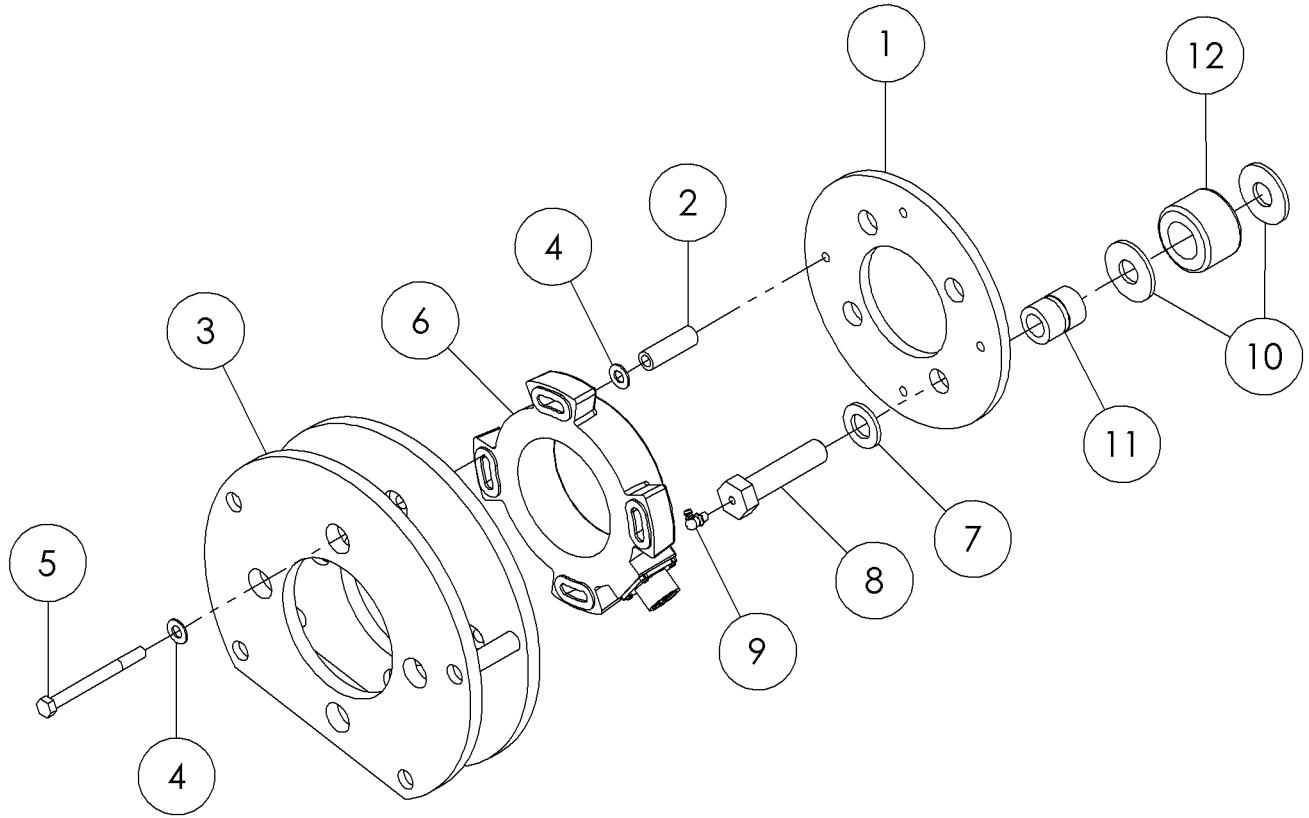



## Strike Alert (S/N 552-567) Fig 7-5

REF. NO.	*	PART NO.	DESCRIPTION	QTY.	REMARKS
1		228049001	PLATE-ROLLER SUPPORT	1	
2		296280269	TUBE-5/8 ODX11GA.-1 15/16"	4	
3		235313001	HOLDER-ROD WIPER	1	
4		235713001	WASHER-FLATSTRL-.38-.41X.81-.06-YA-A325	8	
5		250541001	BOLT-3/8-16 X 4" GR8 HEX Y/ZI	4	
6		296252772	STRIKE ALERT - 4" COIL ASSEMBLY 2000 TURNS	1	
7		235717001	WASHER - 3/4" HARDENED FLAT YZ	4	
8		235915001	BOLT-GREASABLE ROLLER 26184	4	
9		597001	ZERK-1/4" NF 90 DEG GREASE ZYC	4	
10		485017	WASHER-3/4 FLAT	8	
11		244678001	BUSHING GUIDE ROLLER	4	
12		296310860	ROLLER - GUIDE	4	

Tubing Tong Fig 7-6

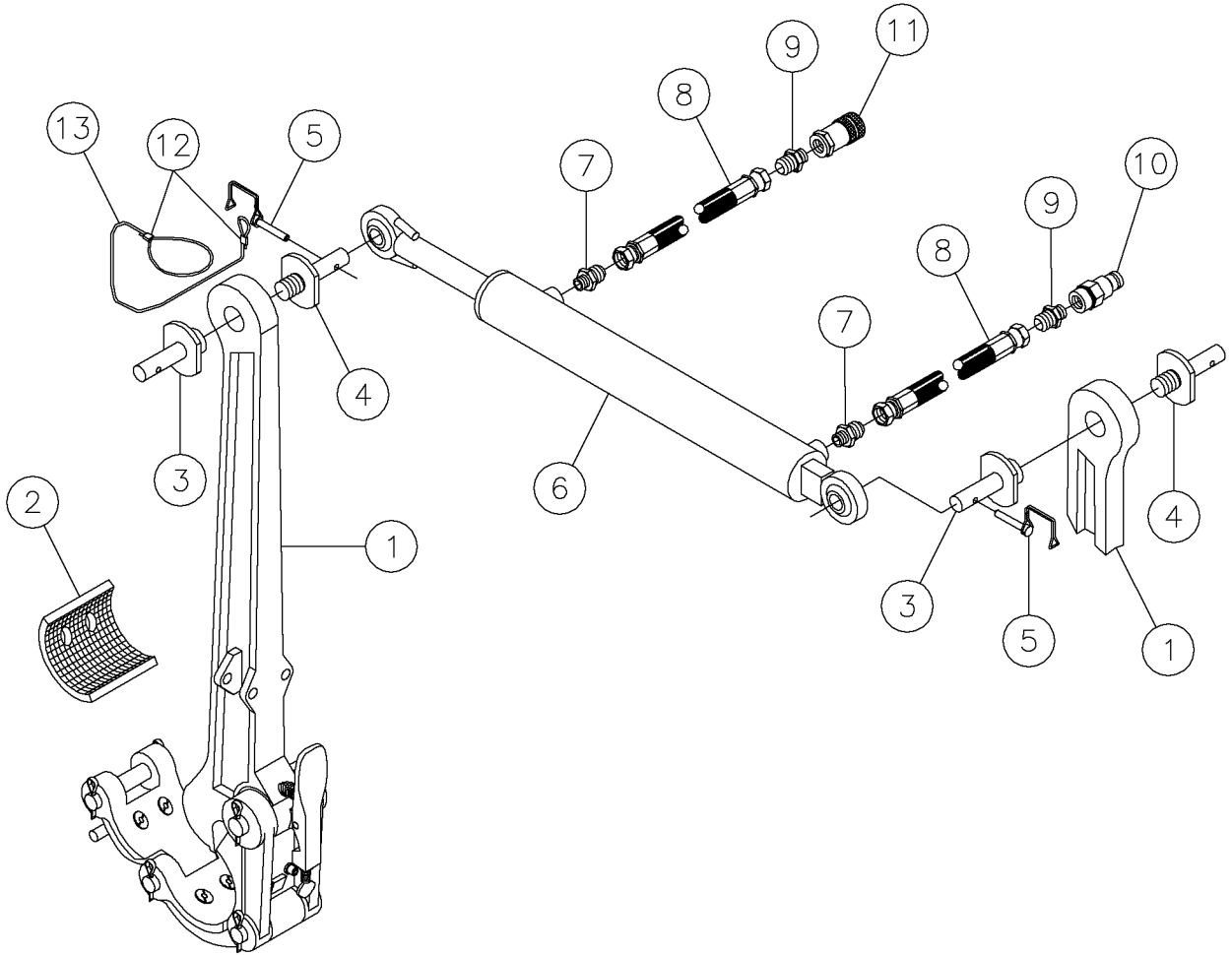

## Tubing Tong Fig 7-6

REF. NO.	*	PART NO.	DESCRIPTION	QTY.	REMARKS
1		230970001	TONG-K30 LIGHT WEIGHT TUBING	2	Breakdown Fig. 7-6z01
2		291546001	K-30 2-3/4" DIE SET (3/SET)	1	
3		234967001	PIN-FEMALE CYLINDER	2	
4		234966001	PIN-MALE CYLINDER	2	
5		2108001	LYNCH PIN - 1/4 X 2	2	
6		230977001	CYLINDER 2"X15 XCX	1	Breakdown Fig. 7-6z02
7		86235001	6M ORING X 8M JIC STR.	2	
8		53844167	HOSE-1/2X240 8FS JIC 3000 PSI	2	
9		68634001	FITTING-3/8MX8M JIC (STR)	2	
10		221503001	COUPLER-3/8 NPT QUICK (MALE)	1	
11		221504001	COUPLER-3/8 NPT QUICK (FEM)	1	
12		1838001	CONNECTOR-WIRE (ETC)	4	
13		240546001	CABLE-3/32 NYLON-18.00	2	

Components-Tubing Tong Fig 7-6z01

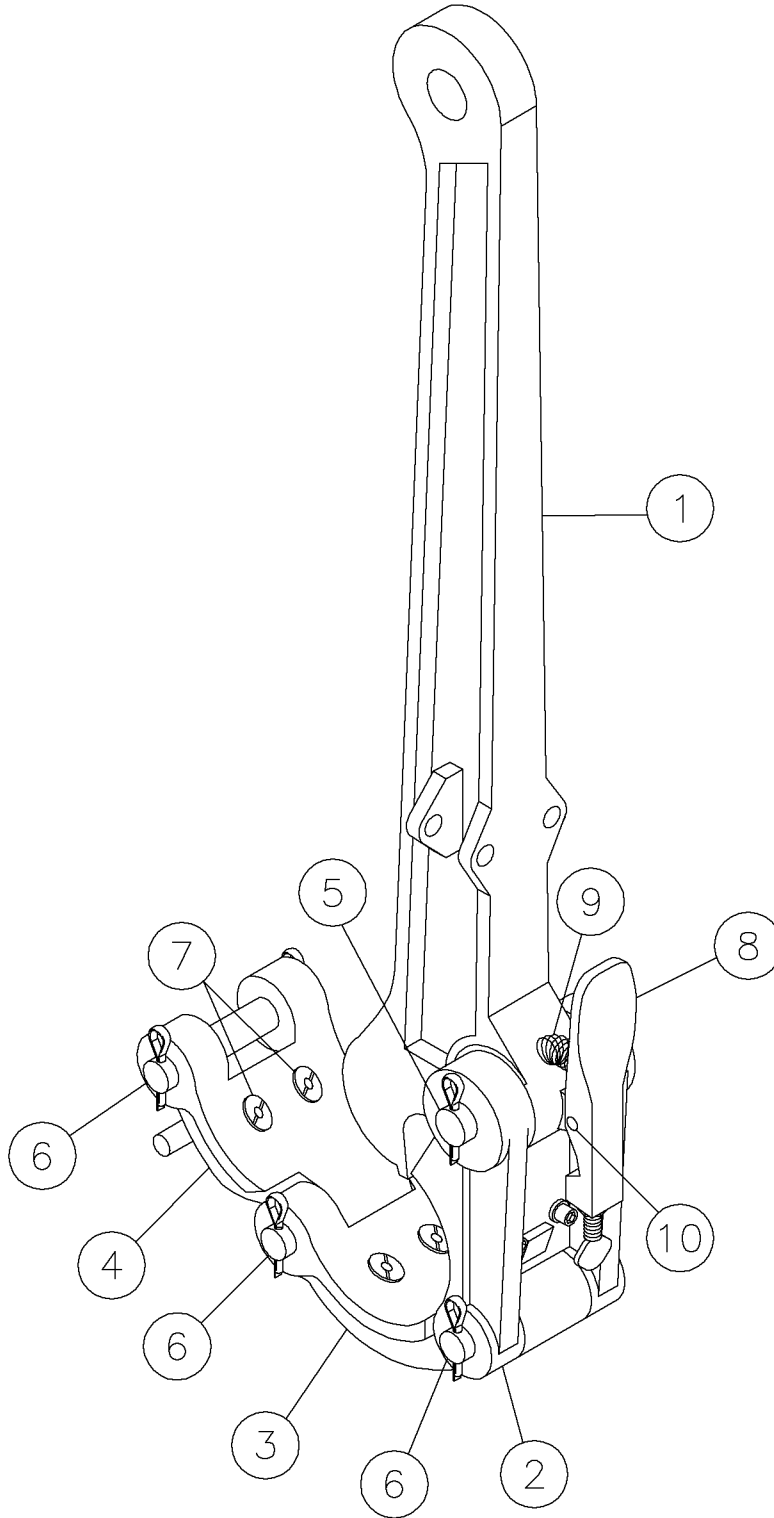

## Components-Tubing Tong Fig 7-6z01

REF. NO.	*	PART NO.	DESCRIPTION	QTY.	REMARKS
1		230970003	TONG HANDLE	1	
2		230970005	HANDLE JAW	1	
3		230970007	CENTER JAW	1	
4		230970009	LATCH JAW	1	
5		230970011	HANDLE PIN	1	
6		230970013	JAW PIN	3	
7		230970015	BUSHING AND SCREW	6	
8		230970017	ADJUSTABLE TONG LATCH	1	
9		230970019	LATCH SPRING	1	
10		230970021	LATCH RIVET	1	
		230970001	TONG-K30 LIGHT WEIGHT TUBING		Inc All Items In Figure.

Components-Tubing Tong Cylinder Fig 7-6z02

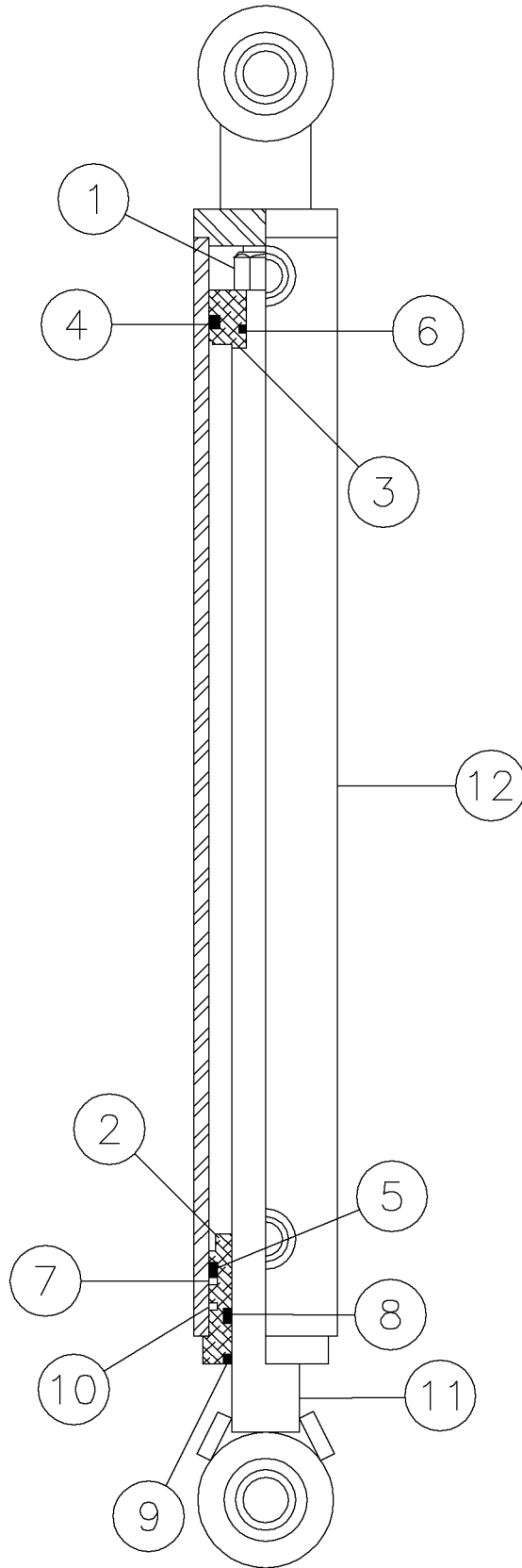

## Components-Tubing Tong Cylinder Fig 7-6z02

REF. NO.	*	PART NO.	DESCRIPTION	QTY.	REMARKS
1		230977003	NUT	1	
2		230977005	HEAD	1	
3		230977007	PISTON	1	
4			PSP-SEAL	1	Not Sold Separately
5			O-RING #326	1	Not Sold Separately
6			O-RING	1	Not Sold Separately
7			BACK-UP	1	Not Sold Separately
8			ROD SEAL	1	Not Sold Separately
9			DUST SEAL	1	Not Sold Separately
10			RETAINING RING1	1	Not Sold Separately
11		230977019	SHAFT (W/CLEVIS)	1	
12		230977021	BARREL W/CLEVIS AND PORTS	1	
		230977001	CYLINDER 2"X15 XCX		Inc. All Items In Figure.
		230977023	REPAIR KIT		Inc. Ref. 4-10

Auto Greaser Fig 7-7

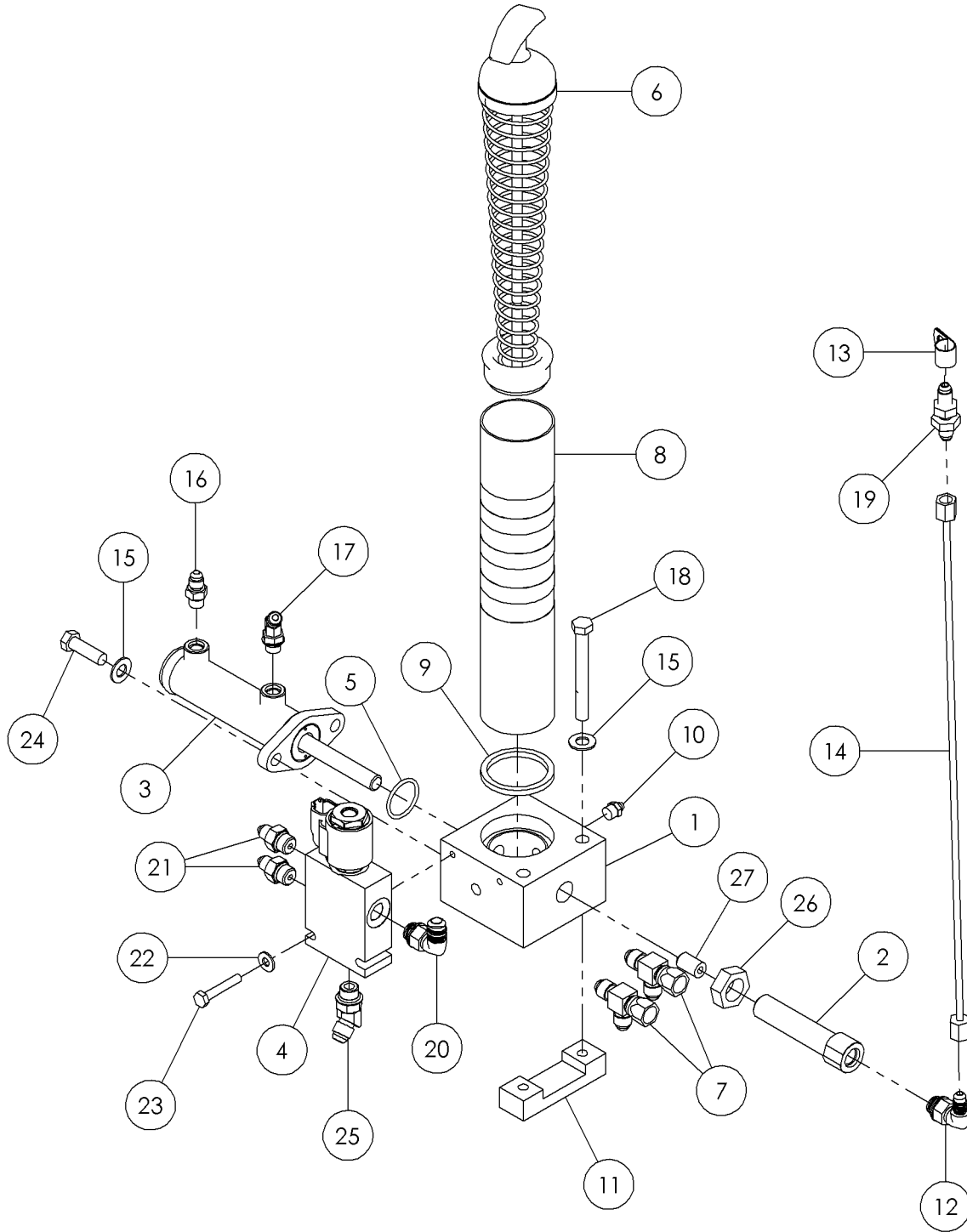

Illustration No. 296292035



## Auto Greaser Fig 7-7

REF. NO.	*	PART NO.	DESCRIPTION	QTY.	REMARKS
1		294895001	HOUSING - GREASE PUMP	1	
2		294896001	SLEEVE - GREASE PUMP	1	
3		294899001	CYLINDER - HYD 1 X 2-3/8	1	Breakdown Fig. 7-7z01
4		294901001	VALVE - GREASER	1	Breakdown Fig. 7-7z02
5		296262010	O-RING - 213 .139 X .921 ID	1	
6		294903001	FOLLOWER - GREASE TUBE AY	1	
7		59427001	TEE-6MJ-6FSJ-6MJ	2	
8		294910001	TUBE - GREASE	1	
9		294902001	GASKET - GREASE TUBE	1	
10		586001	ZERK-1/8" ST NPT GREASE ZYC	1	
11		294908001	BAR - BLOCK MOUNT	1	
12		600118001	FITTING-6MORINGX4MJIC90PARKER	1	
13		279015001	HOSE CLAMP - 9/16 W/13/32 HOLE	1	
14		285556001	HOSE - .078 X 18 4 FS JIC ST/ST 6900 PSI	1	
15		235713001	WASHER-FLATSTRL-.38-.41X.81-.06-YA-A325	4	
16		60908001	FITTING-4MX4M JIC STR ADAPTER	1	
17		58295001	FITTING-4M OR X 4M JIC 45 DEG.	1	
18		240377001	BOLT-3/8-16X3 1/4 GR8 ZINC PLT	2	
19		65564001	FITTING - 4M JIC BULKHEAD ST.	1	
20		59426001	FITTING - 90-6MJ-6MORBA	1	
21		57968001	FITTING-STR-4MJ-6MORB	2	
22		235716001	WASHER-FLATSTRL-.25-.28X.63-.06 - CZ	2	
23		238210001	BOLT - 1/4-20X1 1/2 GR8 HEX ZYC	2	
24		235736001	BOLT-3/8-16X1 1/4 ZYC	2	
25		65563001	FITTING - 6M O-RING X 6M JIC 45 DEGREE	1	
26		510328311	NUT-HEXJAM-.75-16-GR2-YZ	1	
27		294905001	VALVE - INSERT CHECK, 1/2"	1	

Components-Auto Greaser Cylinder Fig 7-7z01

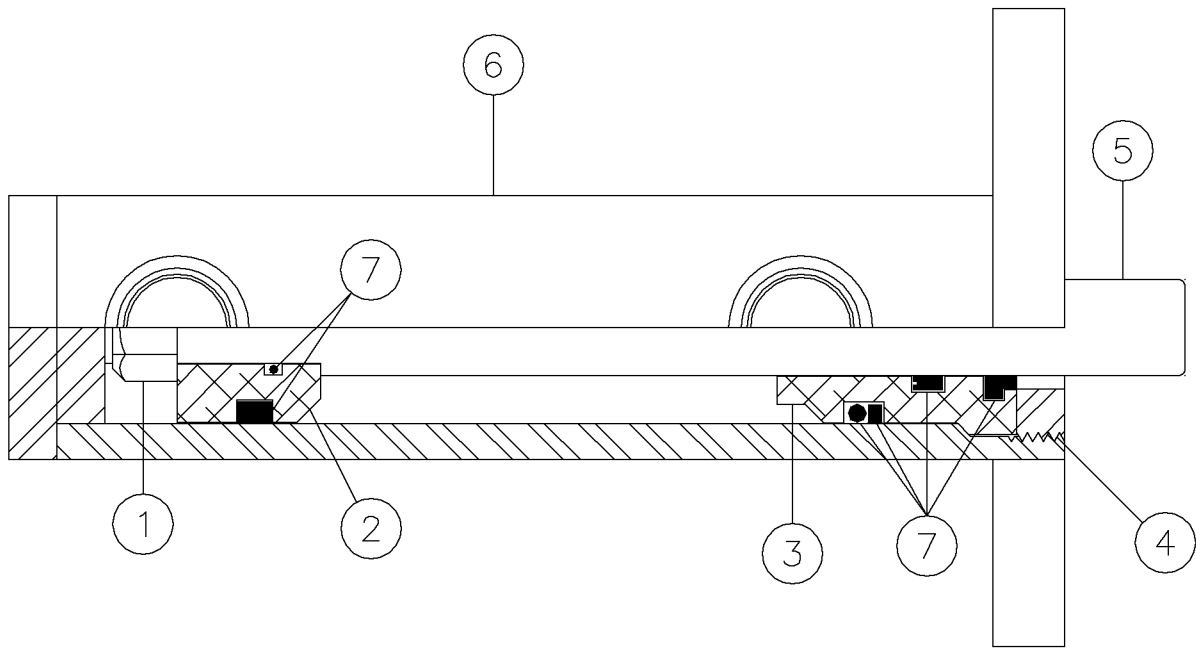

## Components-Auto Greaser Cylinder Fig 7-7z01

REF. NO.	*	PART NO.	DESCRIPTION	QTY.	REMARKS
1		236113003	NUT	1	
2		296251772	PISTON	1	
3		234359007	HEAD	1	
4		234359013	COLLAR	1	
5		296265525	ROD-CYLINDER	1	
6		296265524	BODY-CYLINDER	1	
7		296251775	SEAL KIT	1	
		294899001	CYLINDER - HYD 1 X 2-3/8		Includes All Items In Figure

Components-Auto Greaser Valve Fig 7-7z02

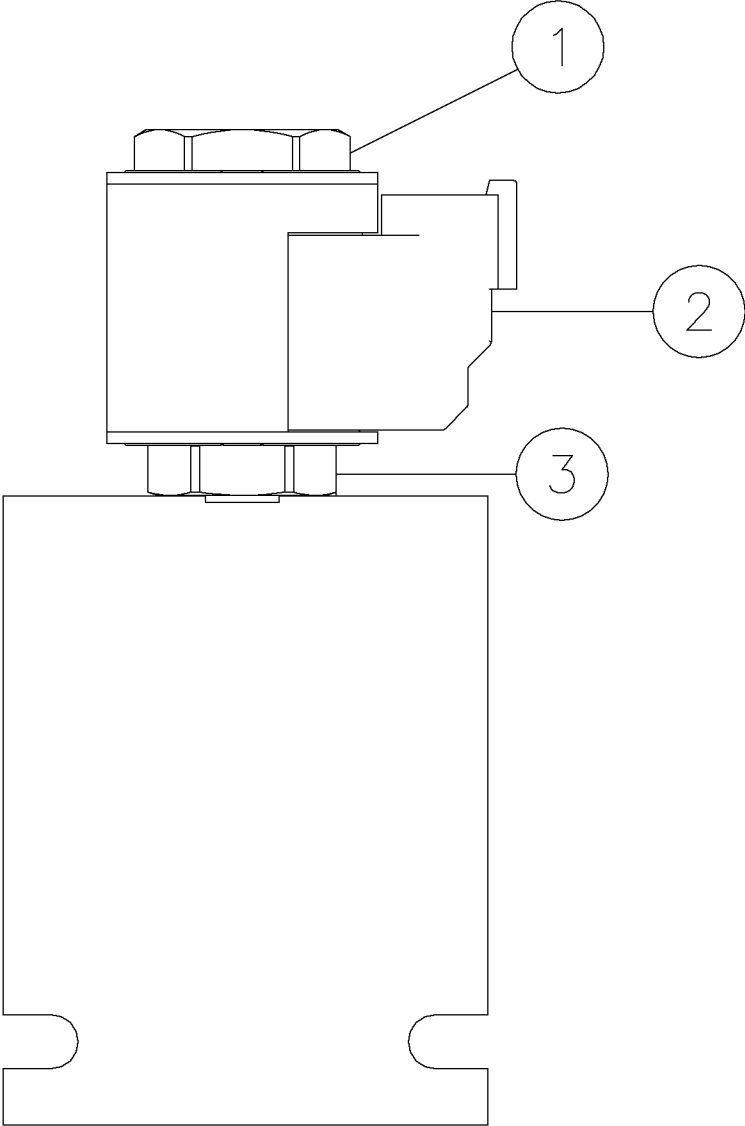

## Components-Auto Greaser Valve Fig 7-7z02

REF. NO.	*	PART NO.	DESCRIPTION	QTY.	REMARKS
1		296265526	NUT-COIL	1	
2		296265527	COIL	1	
3		244725009	CARTRIDGE - SOLENOID	1	
		294901001	VALVE - GREASER		Includes All Items In Figure

Bucket Auto Greaser Mount Fig 7-8

Illustration No. 296287963

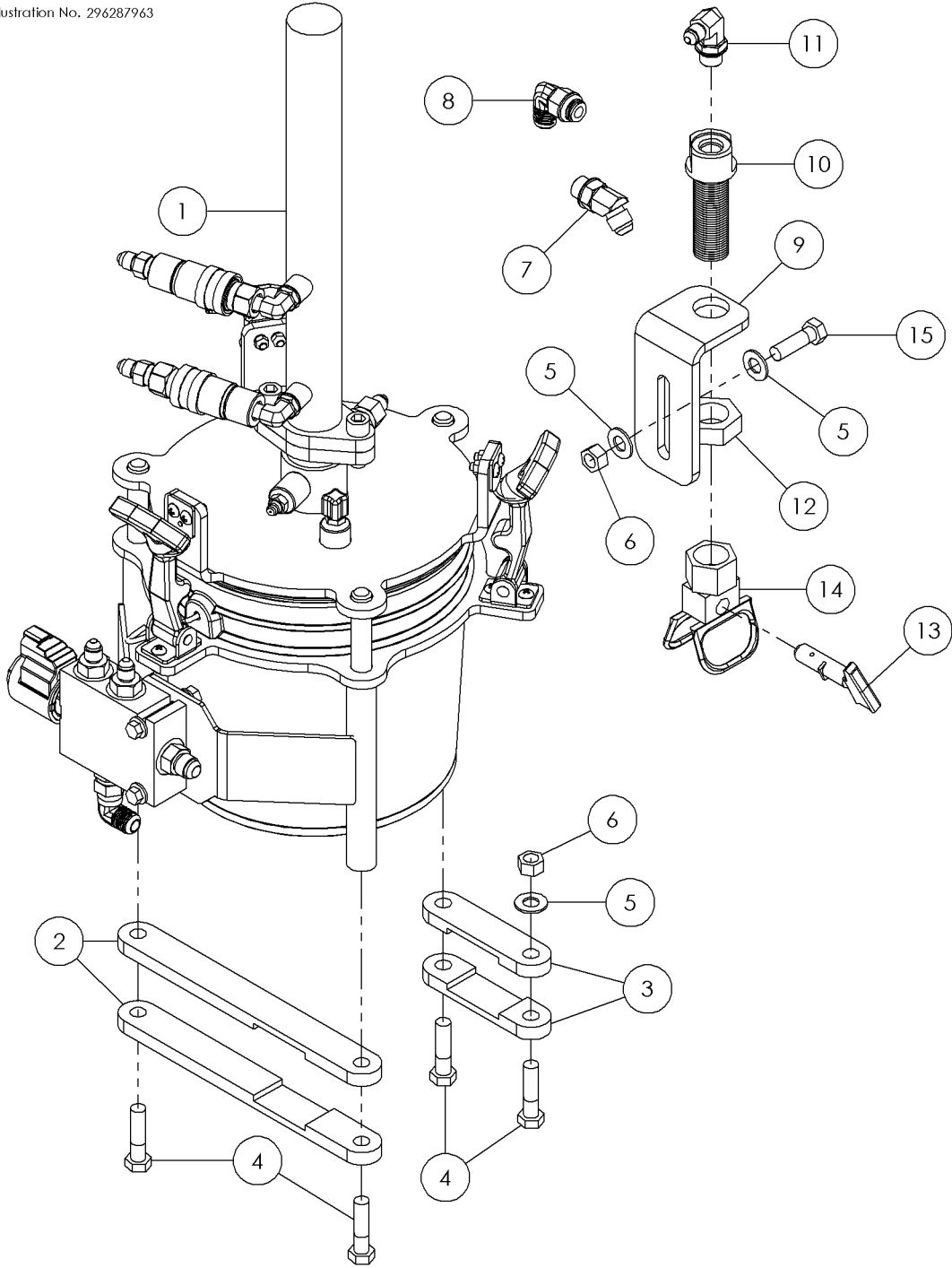

## Bucket Auto Greaser Mount Fig 7-8

REF. NO.	*	PART NO.	DESCRIPTION	QTY.	REMARKS
1		296303114	ASSEMBLY - AUTO GREASER (1GAL)	1	Breakdown Fig. 7-9
2		296289048	PLATE - BUCKET GREASER BASE	2	
3		296289016	PLATE - BUCKET GREASER BASE	2	
4		235723001	SCREW - HCS -.38 - 16 X 1.50 - GR8 - YZ	4	
5		235713001	WASHER-FLATSTRL-.38-.41X.81-.06-YA-A325	7	
6		235725001	NUT - HEX - .38 - 16 - GR8 - YZ	2	
7		65563001	FITTING - 6M O-RING X 6M JIC 45 DEGREE	1	
8		59426001	FITTING - 90-6MJ-6MORBA	1	
9		296303131	BAR - NOZZLE	1	
10		296303130	BAR - NOZZLE MOUNT	1	
11		57950001	FITTING - 90-6MORBA-4MJ	1	
12		284562001	NUT, HEX JAM - .88 - 14 - GR5 - YZ	1	
13		296303135	SPRAY TIP	1	
14		296303136	GUARD TIP	1	
15		235736001	BOLT-3/8-16X1 1/4 ZYC	1	

Bucket Auto Greaser (1 Gal.) Fig 7-9

Illustration No. 296303114

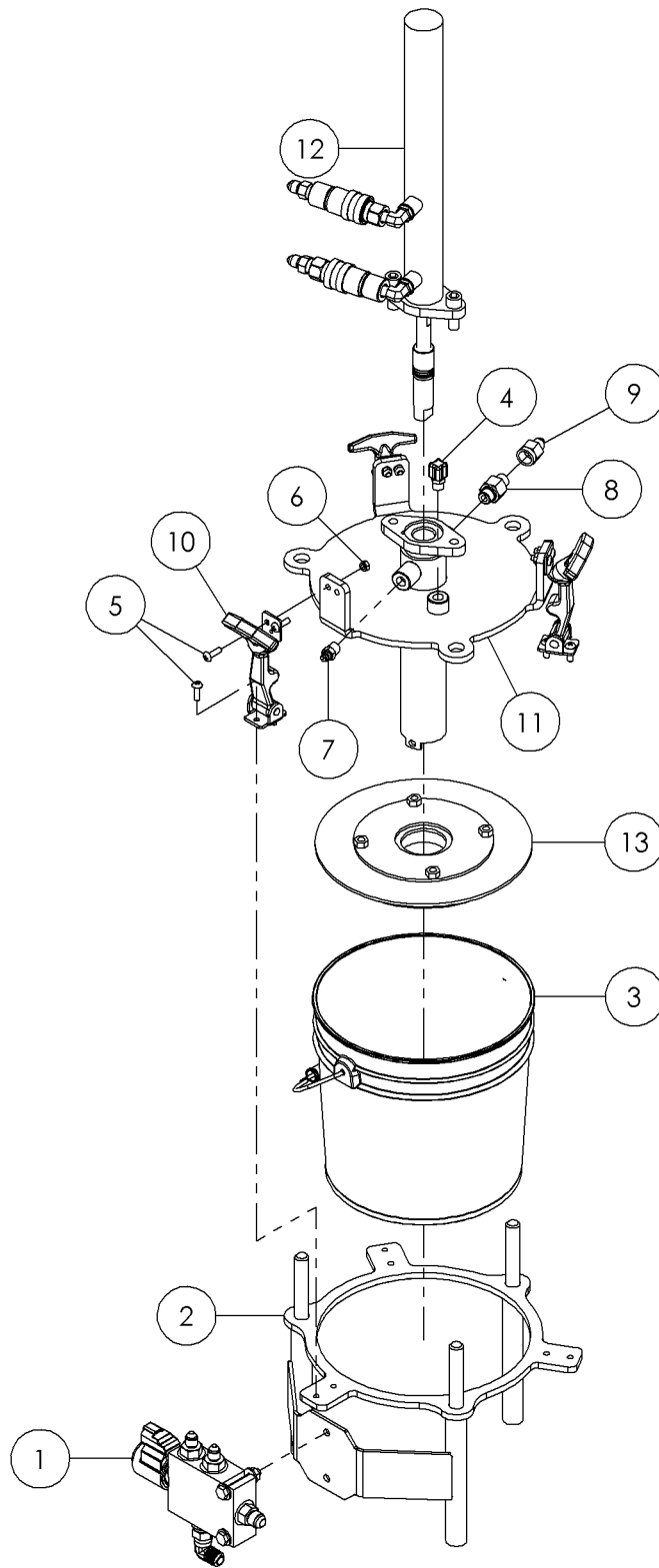



## Bucket Auto Greaser (1 Gal.) Fig 7-9

REF. NO.	*	PART NO.	DESCRIPTION	QTY.	REMARKS
1		296287941	ASSEMBLY - AUTO GREASER VALVE	1	Breakdown Fig. 7-10
2		296289052	WELD - BUCKET SUPPORT	1	
3		235983001	LUBRICANT - THREAD 1 GALLON	1	
4		599001	BREATHER VENT-1/8 NPT 131000	1	
5		233502001	SCREW- #10-24X5/8 PHILLIPS PAN	12	
6		99042001	NUT - NYLOCK - 10 - 24 - GR2 - CZ	12	
7		88978001	ZERK-1/8 NPT STR. LEAK PROOF	1	
8		296280727	FITTING-CHECK VALVE-6MORX6MJIC-40PSI	1	
9		59928001	6F JICX4M JIC ST REDUCER	1	
10		109591001	LATCH-4" RUBBER T HANDLE	3	
11		296303050	GREASER TOP	1	
12		296303115	*CYLINDER - AUTO GREASER	1	Breakdown Fig. 7-11
13		296303104	GREASE FOLLOWER	1	Breakdown Fig. 7-12

Bucket Auto Greaser Valve Fig 7-10

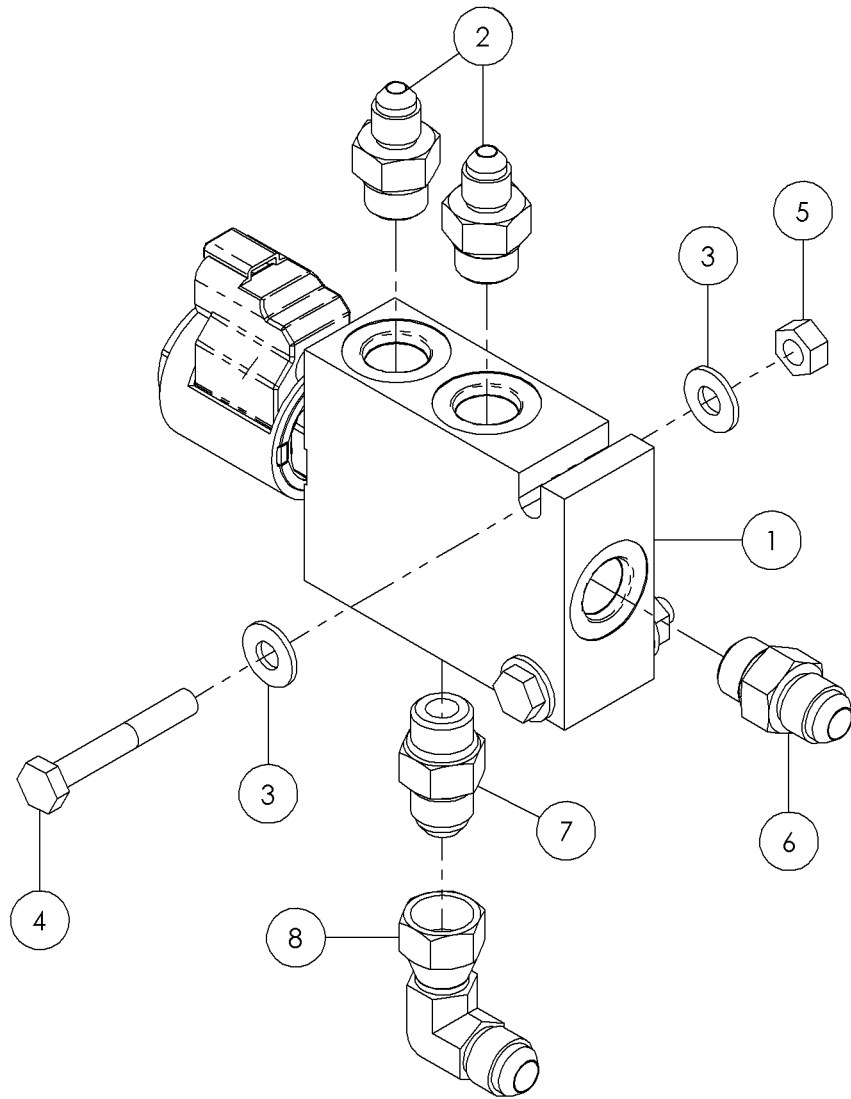

Illustration No. 296287941

## Bucket Auto Greaser Valve Fig 7-10

REF. NO.	*	PART NO.	DESCRIPTION	QTY.	REMARKS
1		294901001	VALVE - GREASER	1	Breakdown Fig. 7-7z02
2		131009001	FITTING-4MJICX6MORING ST.062R	2	
3		235716001	WASHER - FLATSTRL - .25 -.28 X .63 - .06 - CZ	4	
4		248107001	BOLT-1/4-20X1 3/4 GR 8 ZINC PL	2	
5		235732001	NUT - HEX - .25 - 20 - GR8 - YZ	2	
6		65565001	FITTING - 6M O-RING X 6M JIC ST.	1	
7		251575001	VALVE-CHECK 6MORB 6MJIC INLINE	1	
8		60851001	FITTING-6M JICX6FS JIC 90ELBOW	1	

Bucket Auto Greaser Cylinder Fig 7-11

Illustration No. 296303115

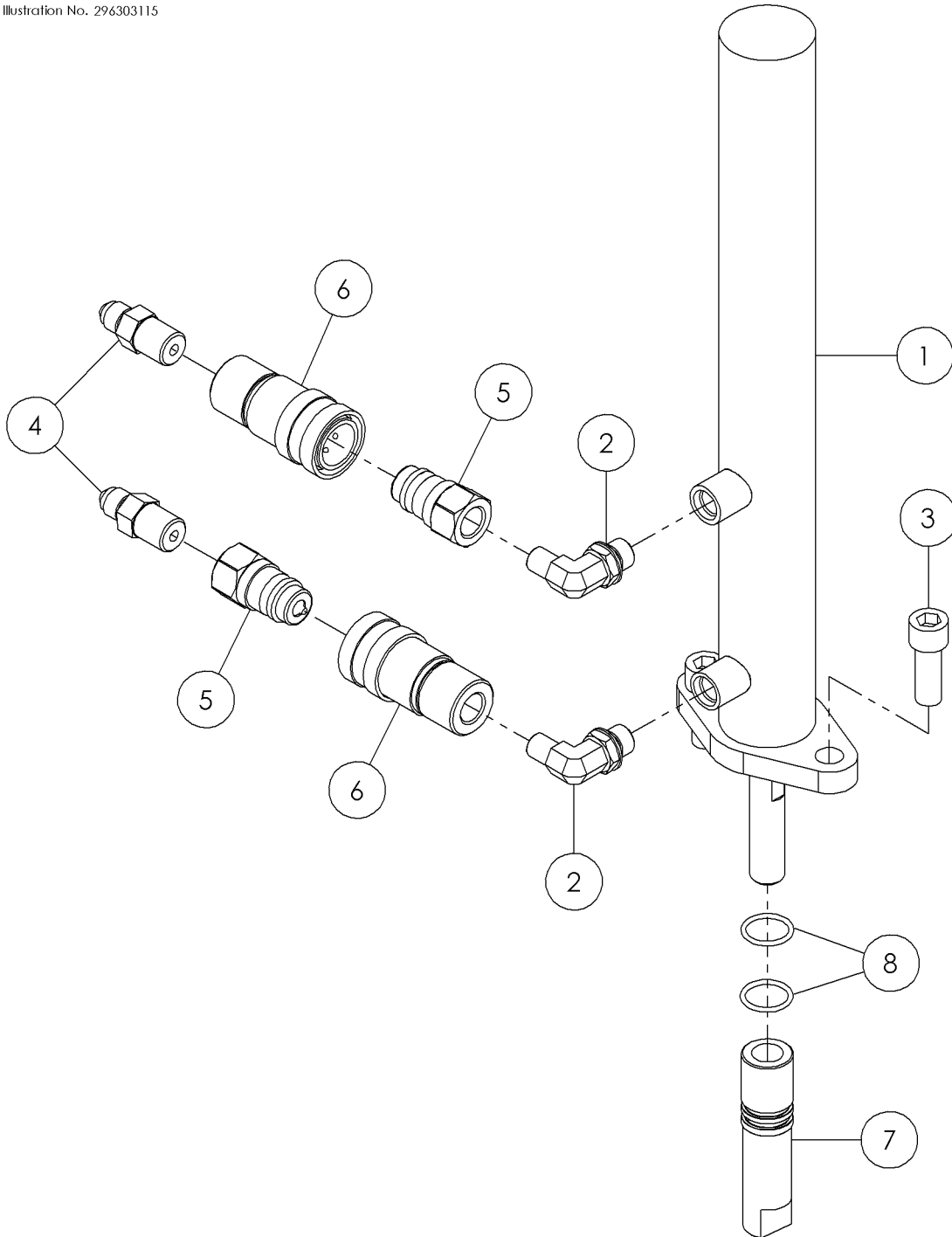

## Bucket Auto Greaser Cylinder Fig 7-11

REF. NO.	*	PART NO.	DESCRIPTION	QTY.	REMARKS
1		296308339	CYL-1.00 BORE X 2.50 STROKE X 0.50 ROD	1	Breakdown Fig. 7-11z01
2		619590001	*FITTING- #4 M ORING X 1/4 MNPT 90 DEG	2	
3		601696010	SOCKET HD CAP SCREW 3/8-16X1 Z	2	
4		67849001	1/4 M X 4M JIC ST.	2	
5		4255003	COUPLER-1/4" M OF QUICK SET	2	
6		4255005	COUPLER-1/4" F OF QUICK SET	2	
7		296303045	SHAFT - PISTON	1	
8		296287959	O-RING - .614ID X .140 WALL	2	

Components-Bucket Auto Greaser Cylinder Fig 7-11z01

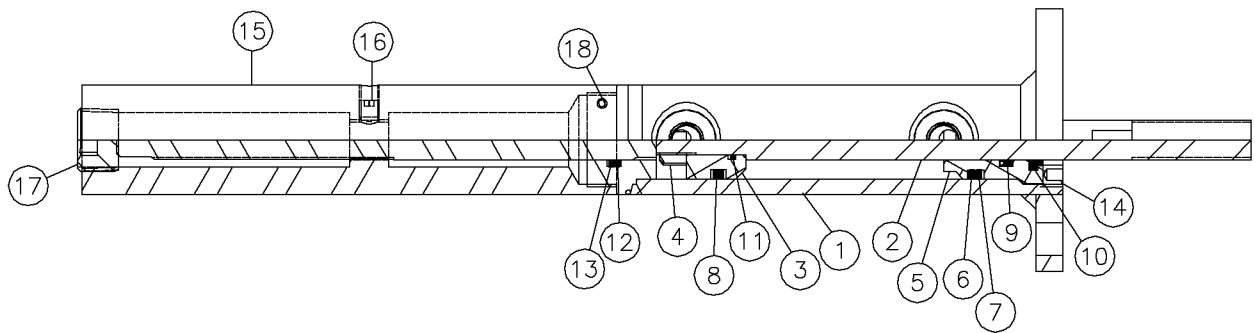

## Components-Bucket Auto Greaser Cylinder Fig 7-11z01

REF. NO.	*	PART NO.	DESCRIPTION	QTY.	REMARKS
1			BARREL ASSY	1	Not Sold Separately
2		296302404	SHAFT ASSY	1	
3			PISTON	1	Not Sold Separately
4			FULL LOCK NUT	1	Not Sold Separately
5			HEAD SHAFT	1	Not Sold Separately
6			O-RING	1	Not Sold Separately
7			BACKUP	1	Not Sold Separately
8			PSP SEAL	1	Not Sold Separately
9			BS SEAL	1	Not Sold Separately
10			DUST SEAL	1	Not Sold Separately
11			O-RING	1	Not Sold Separately
12			O-RING	1	Not Sold Separately
13			BACKUP	1	Not Sold Separately
14			INTERNAL COLLAR	1	Not Sold Separately
15			STROKE ADJUSTER	1	Not Sold Separately
16			SET SCREW	1	Not Sold Separately
17			STEEL PIPE PLUG	1	Not Sold Separately
18			ROLL PIN	1	Not Sold Separately
		296308339	CYL-1.00 BORE X 2.50 STROKE X 0.50 ROD	1	Inc. all Items In Figure.
		296285225	REPAIR KIT		Inc. Ref. 6 Thru 13.

Bucket Auto Greaser Follower (1 Gal.) Fig 7-12

Illustration No. 296303104

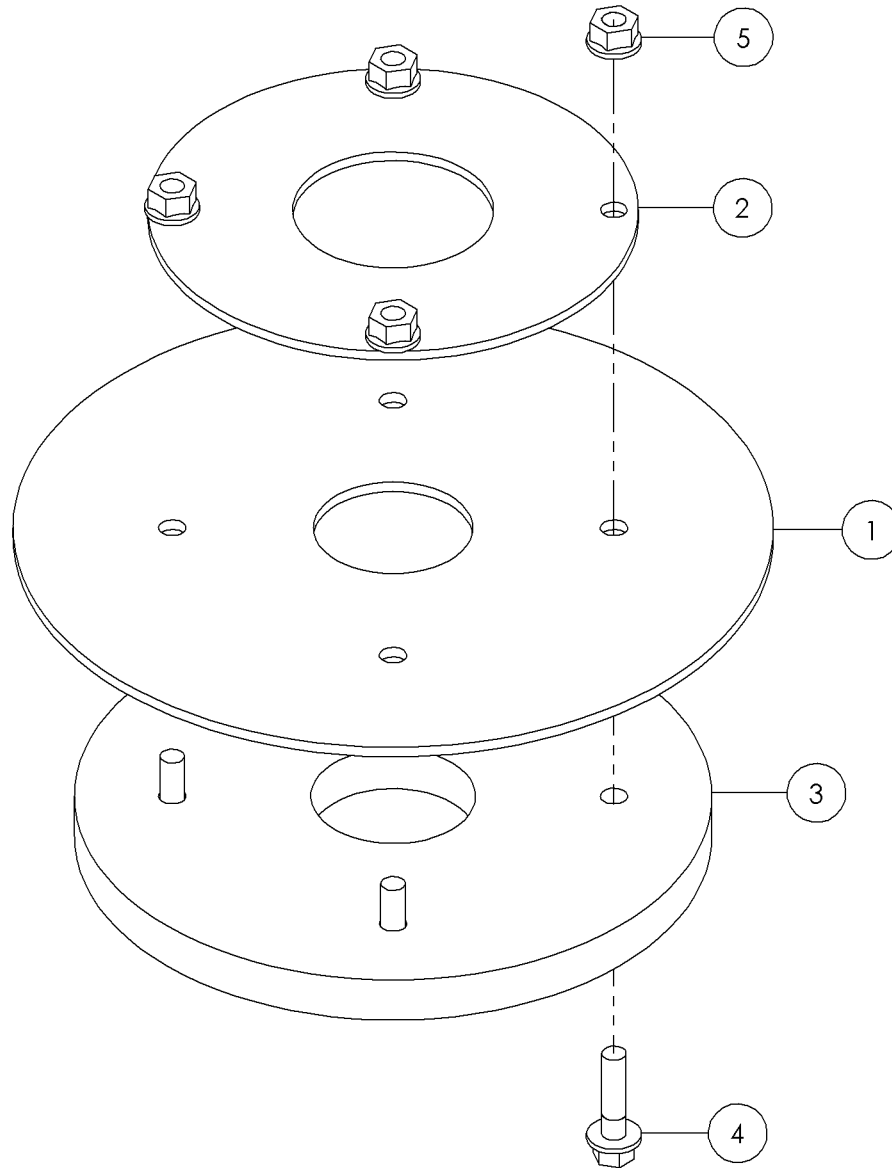



## Bucket Auto Greaser Follower (1 Gal.) Fig 7-12

REF. NO.	*	PART NO.	DESCRIPTION	QTY.	REMARKS
1		296303090	RUBBER WIPER	1	
2		296303013	PLATE - FOLLOWER	1	
3		296303075	PLATE - GREASE FOLLOWER	1	
4		296300754	SCREW-HFS-.25-20X1.00-GR8-YZ	4	
5		296300848	NUT-HEXFLGTL-.25-20-G-YZ	4	

Stakedown (S/N 566-) Fig 7-13r01

Illustration No. 296303244

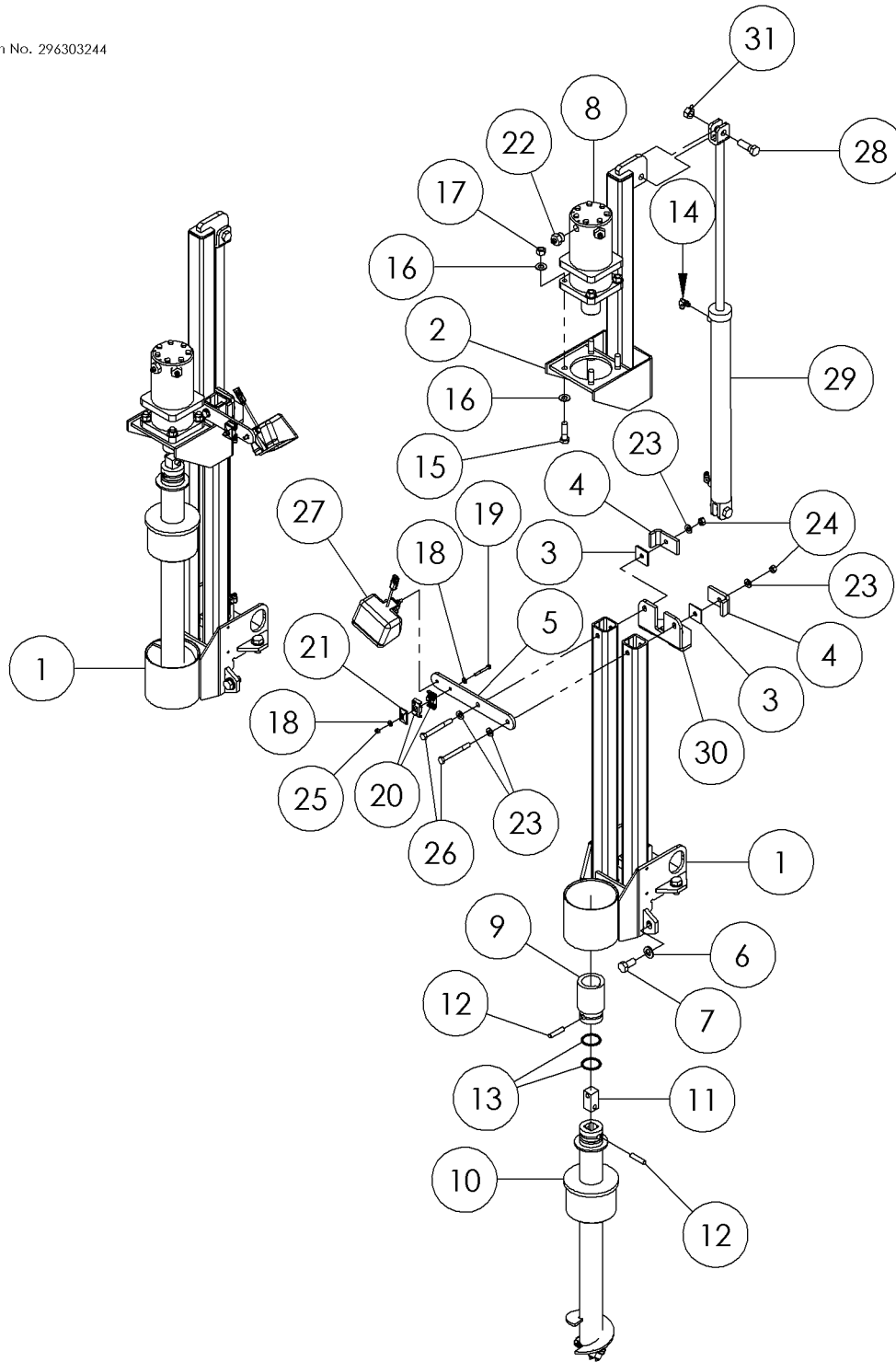

## Stakedown (S/N 566-) Fig 7-13r01

REF. NO.	*	PART NO.	DESCRIPTION	QTY.	REMARKS
1		296303052	WELDMENT - TOWER STAKEDOWN	2	
2		296303051	MOUNT - SLIDE MOUNT	2	
3		236233001	PLATE-SPACER	4	
4		236232001	BAR-GUIDE	4	
5		279150001	BAR-LIGHT REINFORCEMENT	2	
6		235717001	WASHER - 3/4" HARDENED FLAT YZ	8	
7		385014	BOLT-3/4"-10X1 1/2 GR.8 HEX	8	
8		236219001	MOTOR-HYD -66CI	2	Breakdown Fig. 7-13z01
9		236205001	HUB-STAKE DRIVE	2	
10		296303019	STAKE - 6"	2	
11		236230001	BAR-STAKE DRIVE	2	
12		236200001	PIN-STAKE KEEPER	4	
13		236229001	O-RING - 329	4	
14		60906001	4MX6M JIC 90 DEG ELBOW	4	
15		238245001	BOLT 5/8" - 11 X 2 1/4 Gr 8 HEX	8	
16		235715001	WASHER-FLATSTRL-5/8" YZ A325	16	
17		250513001	*NUT - 5/8NC Gr8 TOP LOCK Y/ZINC	8	
18		235714001	WASHER-FLATSTRL-.31-.34X.69-.06-YZ-A325	4	
19		244147001	BOLT-5/16-18X2 1/4 GR8 ZYC	2	
20		900035005	CLAMP-HALF 3/8" DOUBLE (PAIR)	4	
21		67846003	PLATE-TWIN COVER	2	
22		64168001	12MX6 JIC M STR.	4	
23		485025	WASHER-1/2 FLAT-HARDENED-YZ	8	
24		235731001	NUT-1/2-13 GR8 ZYC	4	
25		235741001	NUT - HEX - .31 - 18 - GR8 -YZ	2	
26		250568001	SCREW - HCS-.50-13 X 4.50-GR 8-YZ	4	
27		245006001	ASSEMBLY-3X5 FLOOD LIGHT	2	
28		243921001	*SCREW-HCS-.75-10X2.25-GR8-YZ	4	
29		296303025	CYLINDER 2 X 24	2	Breakdown Fig. 7-13z02
30		296303112	PLATE - CYLINDER SUPPORT	2	
31		250510001	*NUT 3/4 NC Gr8 SLTL Y/ZINC	4	

Stakedown (S/N 552-565) Fig 7-13

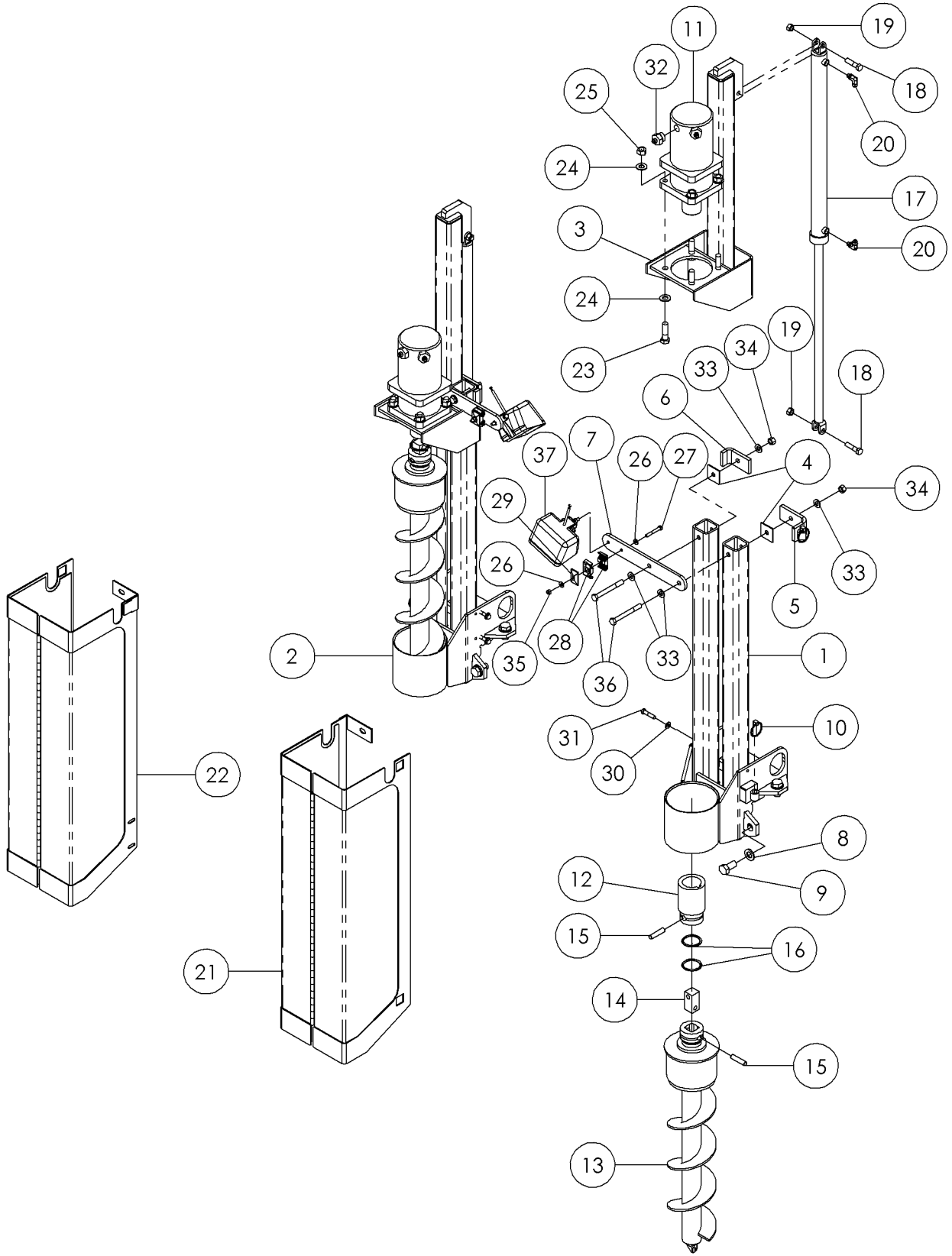
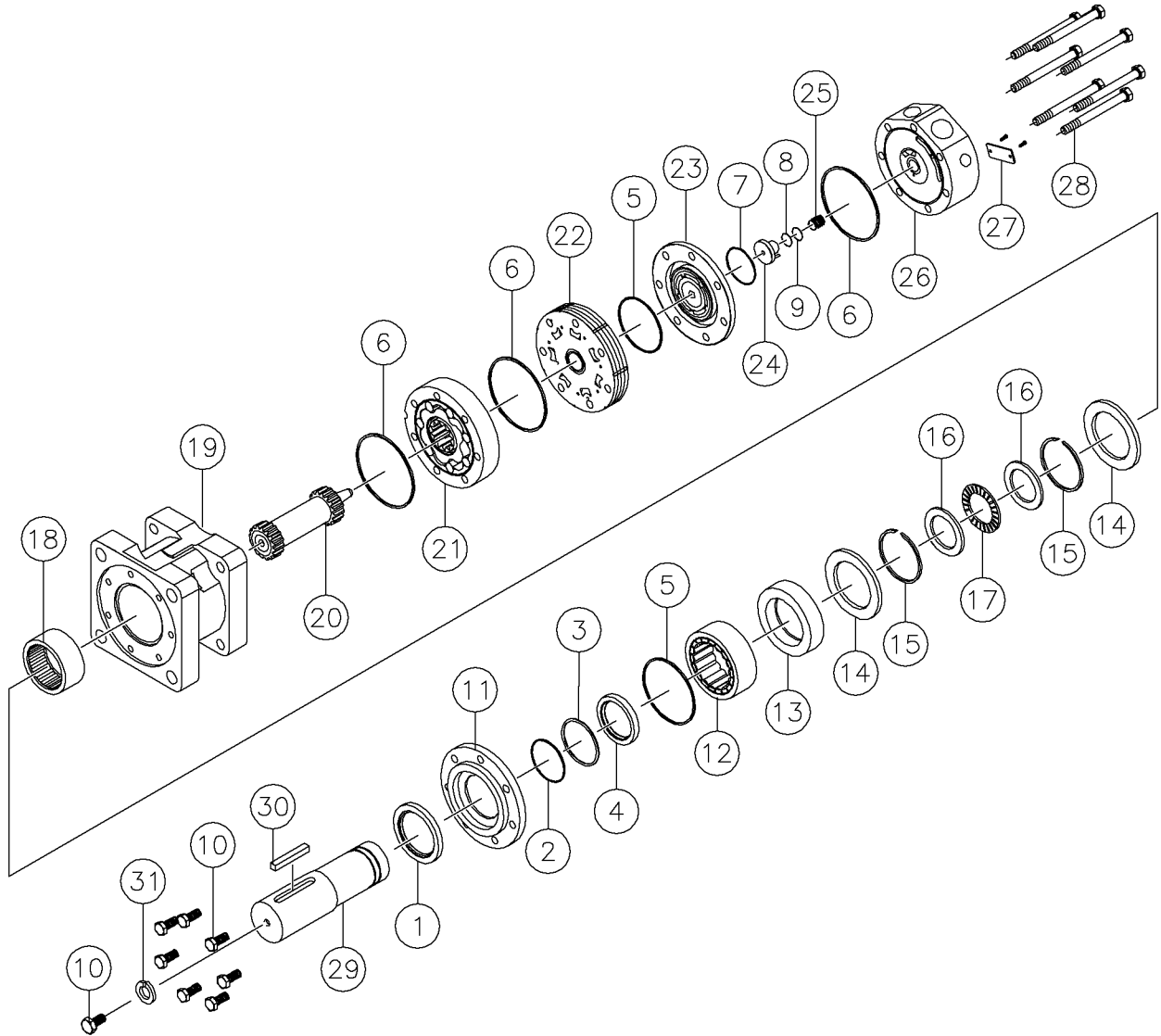

Illustration No. 296279954

## Stakedown (S/N 552-565) Fig 7-13

REF. NO.	*	PART NO.	DESCRIPTION	QTY.	REMARKS
1		296275488	WELDMNT - TOWER STAKEDOWN LEFT	1	
2		296275489	WELDMNT-TOWER STAKEDOWN RIGHT	1	
3		296265765	MOUNT - SLIDE MOTOR	2	
4		236233001	PLATE-SPACER	4	
5		296280264	WELDMNT-MOUNT STAKEDOWN GUARD-UPPER	2	
6		236232001	BAR-GUIDE	2	
7		279150001	BAR-LIGHT REINFORCEMENT	2	
8		235717001	WASHER - 3/4" HARDENED FLAT YZ	8	
9		385014	BOLT-3/4"-10X1 1/2 GR.8 HEX	8	
10		1797001	PIN-QUICK TACH. 7/16X1 3/4	4	
11		236219001	HYD MOTOR-66CI	2	Breakdown Fig. 7-13z01
12		236205001	HUB-STAKE DRIVE	2	
13		232484001	STAKE-6" FLIGHT	2	
14		236230001	BAR-STAKE DRIVE	2	
15		236200001	PIN-STAKE KEEPER	4	
16		236229001	O-RING - 329	4	
17		296285659	CYLINDER - 1-1/2 X 24	2	Breakdown Fig. 7-13z02
18		235718001	BOLT-1/2-13X2 GR8 HEX ZINC PLT	4	
19		75382001	NUT-1/2-UNC GRADE 8 SLTL	4	
20		60906001	4MX6M JIC 90 DEG ELBOW	4	
21		296275438	WELDMNT-STAKE DOWN SHIELD LEFT	1	
22		296275486	WELDMNT-STAKE DOWN SHIELD RIGHT	1	
23		238245001	BOLT 5/8" - 11 X 2 1/4 Gr 8 HEX	8	
24		235715001	WASHER-FLATSTRL-5/8" YZ A325	16	
25		238221001	NUT - HEX -.63 - 11 - GR8 - YZ	8	
26		235714001	WASHER- FLATSTRL-.31-.34X.69-.06-YZ-A325	4	
27		244147001	BOLT-5/16-18X2 1/4 GR8 ZYC	2	
28		900035005	CLAMP-HALF 3/8" DOUBLE (PAIR)	4	
29		67846003	PLATE-TWIN COVER	2	
30		235713001	WASHER-FLATSTRL-.38-.41X.81-.06-YA-A325	4	
31		235720001	BOLT-3/8-16X1 3/4 6R8 ZINC PLT	4	
32		64168001	12MX6 JIC M STR.	4	
33		485025	WASHER-1/2 FLAT-HARDENED-YZ	8	
34		235731001	NUT-1/2-13 GR8 ZYC	4	
35		235741001	NUT - HEX - .31 - 18 - GR8 - YZ	2	
36		250568001	SCREW - HCS-.50-13 X 4.50-GR 8-YZ	4	
37		245006001	ASSEMBLY-3X5 FLOOD LIGHT	2	

Components- Motor Fig 7-13z01



## Components- Motor Fig 7-13z01

REF. NO.	*	PART NO.	DESCRIPTION	QTY.	REMARKS
1			SEAL-DUST	1	Not Sold Separately
2			SHIM-METAL BACKUP	1	Not Sold Separately
3			SEAL-TEFLON BACKUP	1	Not Sold Separately
4			SEAL-SHAFT	1	Not Sold Separately
5			SEAL-LATHE CUT	2	Not Sold Separately
6			SEAL-BODY	3	Not Sold Separately
7			SEAL COMMUTATOR	1	Not Sold Separately
8			SEAL O-RING	1	Not Sold Separately
9			SEAL-TEFLON BACKUP	1	Not Sold Separately
10		383010	BOLT-1/2-20X1 GR.8 HEX HEAD	8	
11		236219007	RING-PILOT	1	
12		236219009	BEARING-2 1/2" ROLLER	1	
13		236219011	SPACER-BEARING	1	
14		236219013	WASHER-RETAINING	2	
15		236219015	SNAP RING	2	
16		236219017	WASHER-THRUST	2	
17		236219019	BEARING-THRUST	1	
18		236219021	BEARING-REAR HOUSING	1	
19		236219023	HOUSING	1	
20		236219025	DRIVE LINK	1	
21		236219027	ROTOR ASSEMBLY	1	
22		236219029	MANIFOLD	1	
23		236219031	COMMUTATOR ASSEMBLY	1	
24		236219033	PISTON-ENDCOVER	1	
25		236219035	SPRING-PISTON	1	
26		236219037	ENDCOVER	1	Inc. Ref. 8, 9, 24, And 25
27			I.D. TAG ASSEMBLY	1	Not Sold Separately
28		236219039	BOLT	7	
29		236219041	SHAFT-ASSEMBLY	1	Inc. Ref. 1-5, 10-17, And 29-31
30		236219005	KEY-SHAFT	1	
31		480011	WASHER-1/2 S/T LOCK	1	
		236219001	HYD MOTOR-66CI		Inc. All Items In Figure
		236219003	SEAL KIT-HYD. MOTOR		Inc. Ref. 1-9

Components- Cylinder Fig 7-13z02

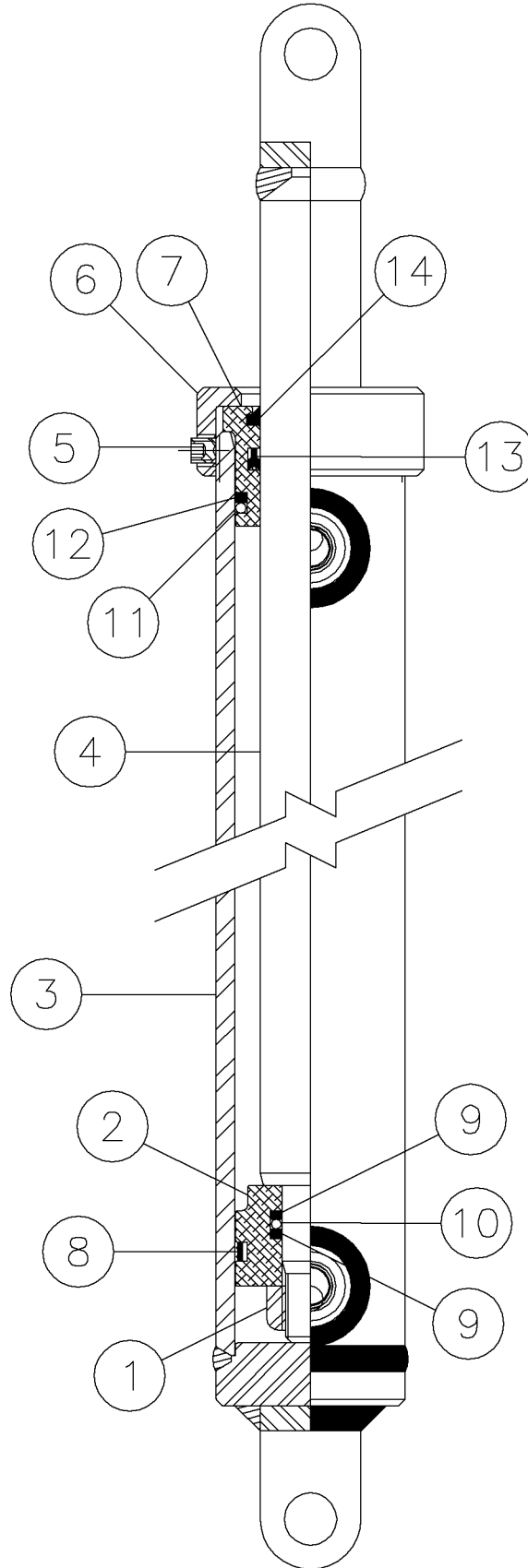



## Components- Cylinder Fig 7-13z02

REF. NO.	*	PART NO.	DESCRIPTION	QTY.	REMARKS
1		202722001	LOCKNUT	1	
2		287588004	PISTON	1	
3		287588005	BARREL ASSEMBLY	1	
4		287588006	ROD ASSEMBLY	1	
5		223998013	SET SCREW	1	
6		287588007	THREAD CAP	1	
7		287588008	THREAD CAP HEAD	1	
8			PSP SEAL	1	Not Sold Separately
9			BACKUP	1	Not Sold Separately
10			O-RING	1	Not Sold Separately
11			O-RING	1	Not Sold Separately
12			BACKUP	1	Not Sold Separately
13			LOADED V-CUP	1	Not Sold Separately
14			ROD WIPER	1	Not Sold Separately
		287588001	CYLINDER - 1-1/2 X 24		Inc. All Items In Figure
		287588002	SEAL KIT		Inc. Ref. 8-14

Valve-Stakedown Fig 7-14

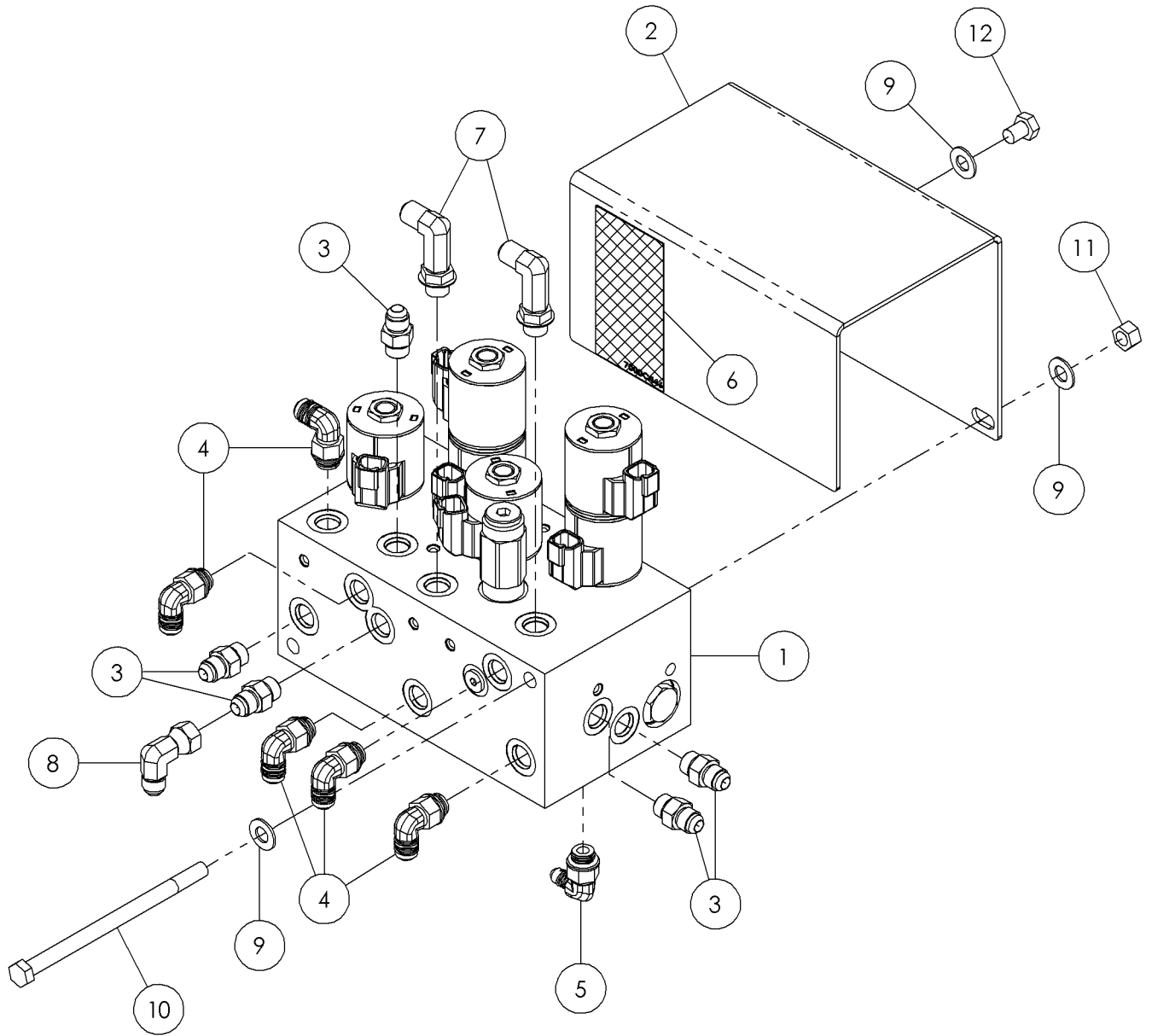
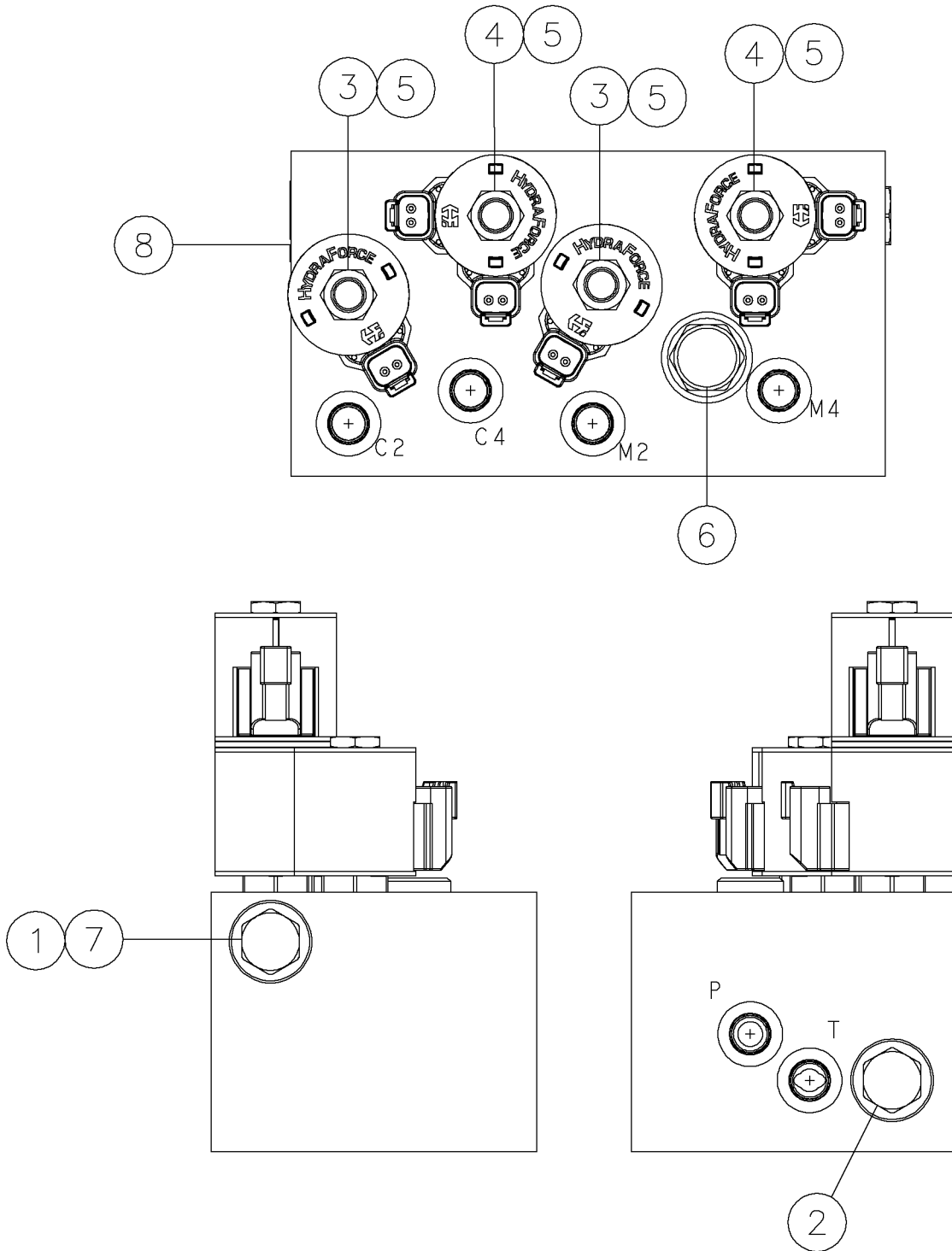

Illustration No. 296279926

## Valve-Stakedown Fig 7-14

REF. NO.	*	PART NO.	DESCRIPTION	QTY.	REMARKS
1		296289188	VALVE-STAKEDOWN	1	Breakdown Fig. 7-14z01
2		279093001	SHIELD-VALVE	1	
3		65565001	FITTING - 6M O-RING X 6M JIC ST.	5	
4		59426001	FITTING - 90-6MJ-6MORBA	5	
5		600118001	FITTING-6MORINGX4MJIC90PARKER	1	
6		7000C446	DECAL - NO WELD	1	
		700IC446	DECAL - NO WELD	1	
7		65570001	6M X 6M JIC 90 DEGREE LONG	2	
8		60851001	FITTING-6M JICX6FS JIC 90ELBOW	1	
9		235713001	WASHER-FLATSTRL-.38-.41X.81-.06-YA-A325	5	
10		238214001	BOLT 3/8-16 X 6" Gr8 HEX Y\ZINC	2	
11		250508001	NUT - 3/8-NC Gr8 TOP LOCK Y/ZINC	2	
12		240310001	SCREW - HCS - .38 - 16 X .50 - GR8 - YZ	1	

Components-Valve Fig 7-14z01



## Components-Valve Fig 7-14z01

REF. NO.	*	PART NO.	DESCRIPTION	QTY.	REMARKS
1		296276779	CHECK VALVE	1	
		296265595	SEAL KIT		
2		296276878	CHECK VALVE	1	
		296265595	SEAL KIT		
3		296276880	SOLENOID VALVE	2	
		251118005	SEAL KIT		
4		296271086	SOLENOID VALVE	2	
		296265599	SEAL KIT		
5		296271077	COILS	6	
6		296302294	REGULATOR - PRESSURE FLOW	1	
		500659019	SEAL KIT-SOLENOID,SPOOL,2-WAY	1	
7		246415003	PILOT PISTON	1	
8			BLOCK		Not Sold Separately
		296289188	VALVE-STAKEDOWN		Inc. All Items In Figure

Vise Dies/Rod Wipers Fig 7-15

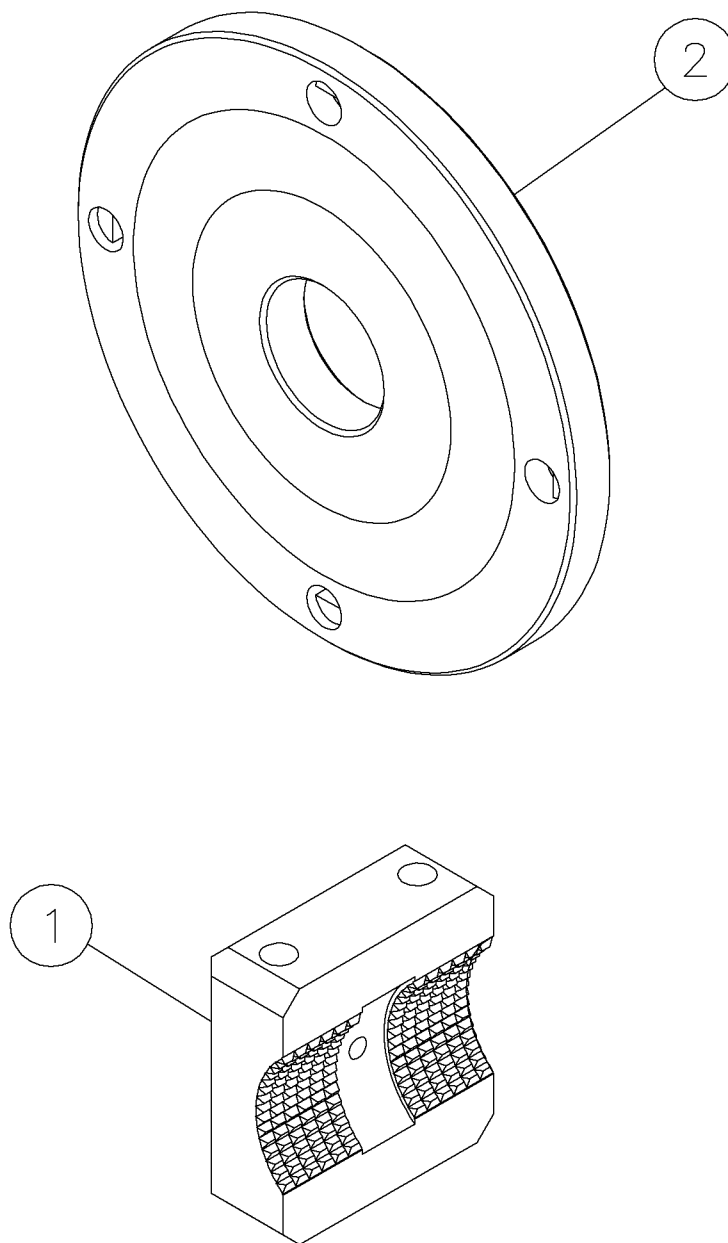

## Vise Dies/Rod Wipers Fig 7-15

REF. NO.	*	PART NO.	DESCRIPTION	QTY.	REMARKS
1		230831001	DIE-CONTOUR VERMEER 2 5/8	4	
1		276415001	DIE - JAW 2 3/4 OD	4	
1		296310768	DIE - JAW 3.10" OD	4	
2		235924001	WIPER-2 3/8 OD ROD	1	
2		296274193	ROD-WIPER 2 5/8 FSTII (ID 2 3/8)	1	

Motor-10' Rod Loader Fig 8-1

Illustration No. 296307465

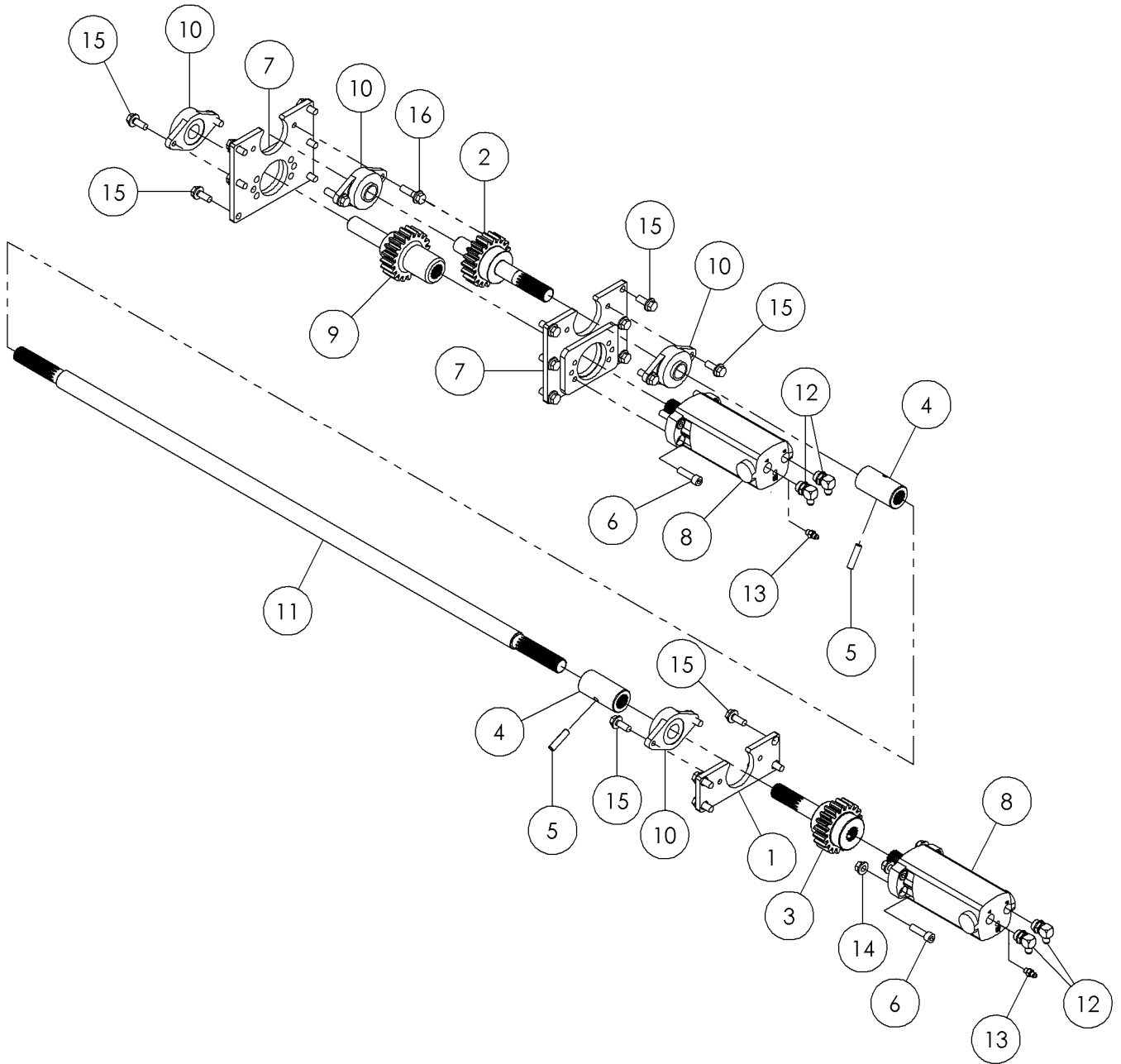



## Motor-10' Rod Loader Fig 8-1

REF. NO.	*	PART NO.	DESCRIPTION	QTY.	REMARKS
1		296287861	PLATE - BEARING	1	
2		296269731	GEAR - SPLINED REAR ROD LOADER	1	
3		296269732	GEAR - SPINED FRONT ROD LOADER GEAR	1	
4		296287853	HUB - 1.25 14T SPLINE	2	
5		296287915	1/2 X 2" ROLL PIN	2	
6		243907001	SCREW-1/2 - 13X1 3/4 SHC ZP	8	
7		296307431	BEARING/MOTOR MOUNT	2	
8		296287807	MOTOR-HDY 4K COMPACT	2	Breakdown Fig. 8-1z01
9		296305777	GEAR - LOWER ROD LOADER	1	
10		246416001	BEARING- 2 BOLT FLANGE	4	
11		296287862	WELDMENT - SPLINE SYNCRO TUBE	1	
12		59401001	6M JICX10M ADJ. 90 DEG.ELBOW FITTING	4	
13		60908001	FITTING-4MX4M JIC STR ADAPTER	2	
14		296300851	NUT-HEXFLGTL-.50-13-G-YZ	4	
15		296300789	SCREW-HFS-.50-13X1.25-GR8-YZ	22	
16		296300791	SCREW-HFS-.50-13X1.75-GR8-YZ	2	

Components-Motor Rod Loader Fig 8-1z01

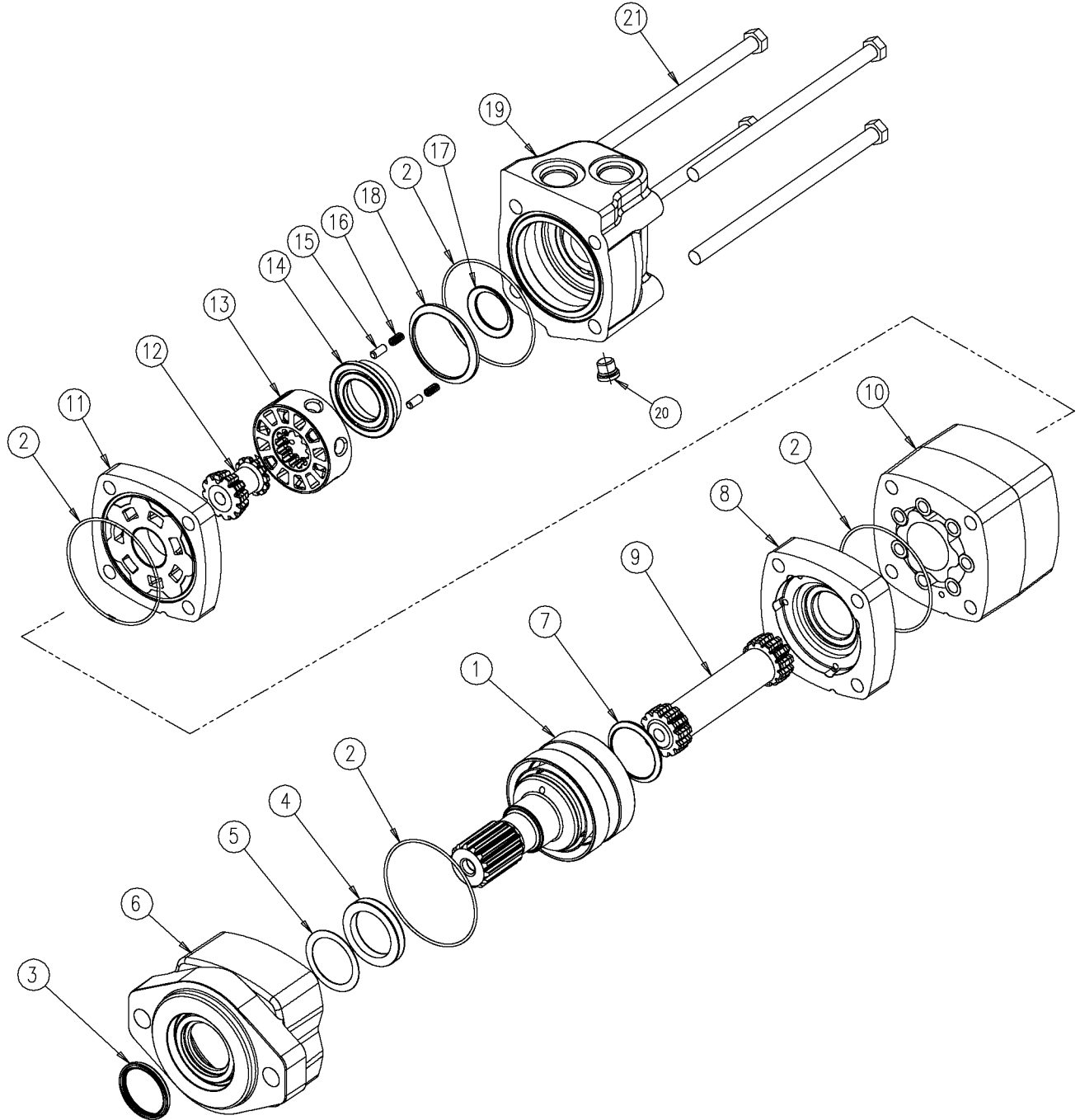

## Components-Motor Rod Loader Fig 8-1z01

REF. NO.	*	PART NO.	DESCRIPTION	QTY.	REMARKS
1		180005753	SHAFT-SUB ASSY	1	
2		770007	SEAL-O RING 9022-6	4	
3		770071	SEAL-DUST # 9121-1	1	
4		296285188	SEAL-SHAFT	1	
5		260576013	WASHER-BACKUP	1	
6		26285189	HOUSING-BEARING	1	
7		296271183	SHAFT - SHAFT FACE	1	
8		180005755	PLATE WEAR	1	
9		180005756	DRIVE	1	
10		296285190	GEROLD SUB-ASSY	1	
11		180005757	PLATE - VALVE	1	
12		180005758	DRIVE - VALVE	1	
13		243316017	VALVE	1	
14		770089	PLATE-BALANCE #8915	1	
15		243316023	PIN	2	
16		770039	SPRING-7383	2	
17		770057	SEAL-FACE INNER 9049-1	1	
18		770091	SEAL-FACE OUTER #9135-2	1	
19		770093	HOUSING-(SAE 10 PORTS)#21564-1	1	
20		180005760	PLUG - SUB ASSY	1	
21		180005761	SCREW-CAP	4	
		296287807	MOTOR-HYD. 4K COMPACK		Inc. All Items In Figure
		296285191	SEAL KIT		

Motor-15' Rod Loader Fig 8-2

Illustration No. 296307464

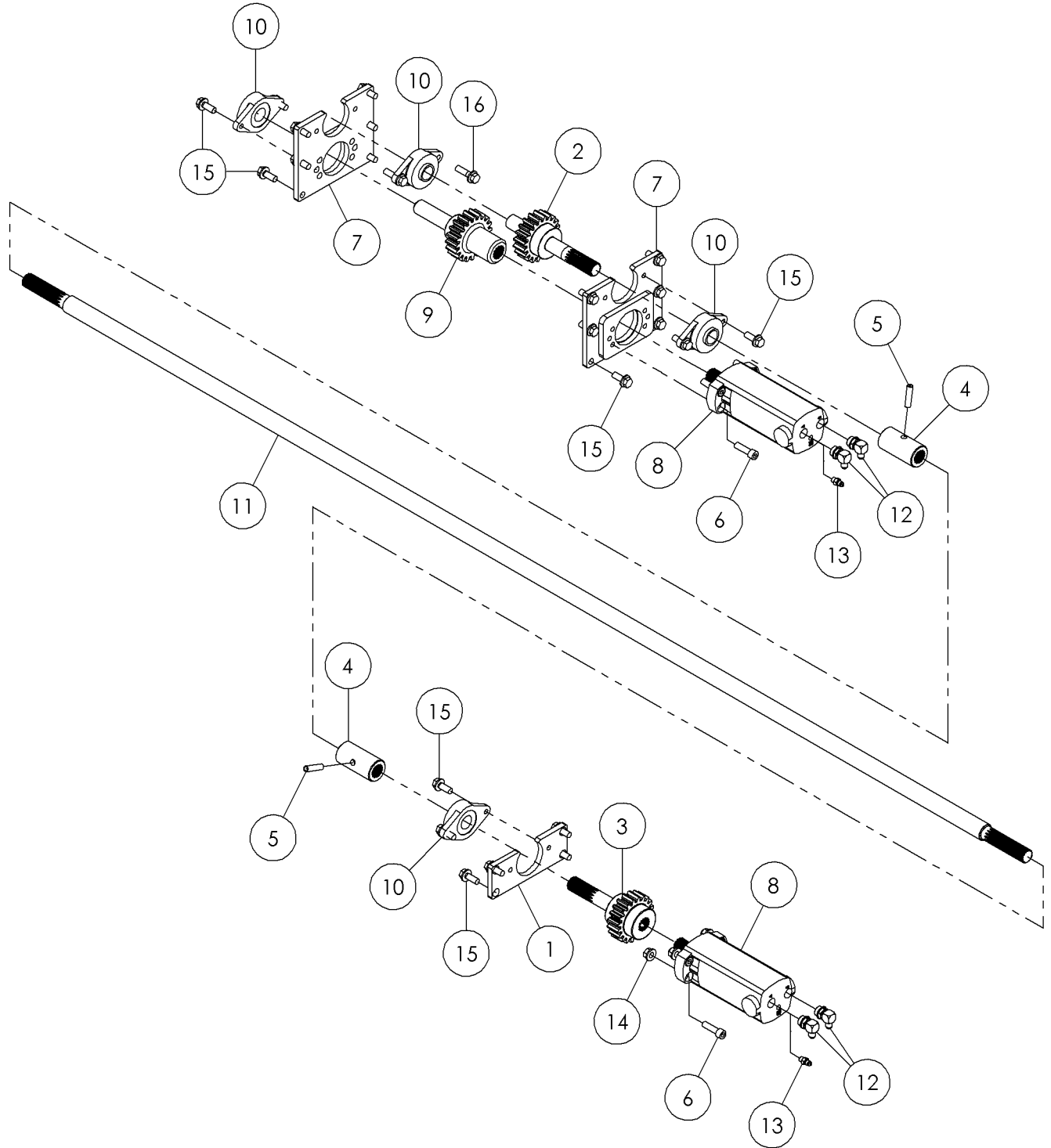

## Motor-15' Rod Loader Fig 8-2

REF. NO.	*	PART NO.	DESCRIPTION	QTY.	REMARKS
1		296287861	PLATE - BEARING	1	
2		296269731	GEAR - SPLINED REAR ROD LOADER	1	
3		296269732	GEAR - SPINED FRONT ROD LOADER GEAR	1	
4		296287853	HUB - 1.25 14T SPLINE	2	
5		296287915	1/2 X 2" ROLL PIN	2	
6		243907001	SCREW-1/2 - 13X1 3/4 SHC ZP	8	
7		296307431	BEARING/MOTOR MOUNT	2	
8		296287807	MOTOR-HDY 4K COMPACT	2	
9		296305777	GEAR - LOWER ROD LOADER	1	
10		246416001	BEARING- 2 BOLT FLANGE	4	
11		296287896	WELDMENT - SPLINE SYNCRO TUBE	1	
12		59401001	6M JICX10M ADJ. 90 DEG.ELBOW FITTING	4	
13		60908001	FITTING-4MX4M JIC STR ADAPTER	2	
14		296300851	NUT-HEXFLGTL-.50-13-G-YZ	4	
15		296300789	SCREW-HFS-.50-13X1.25-GR8-YZ	22	
16		296300791	SCREW-HFS-.50-13X1.75-GR8-YZ	2	

Guard Fig 8-3

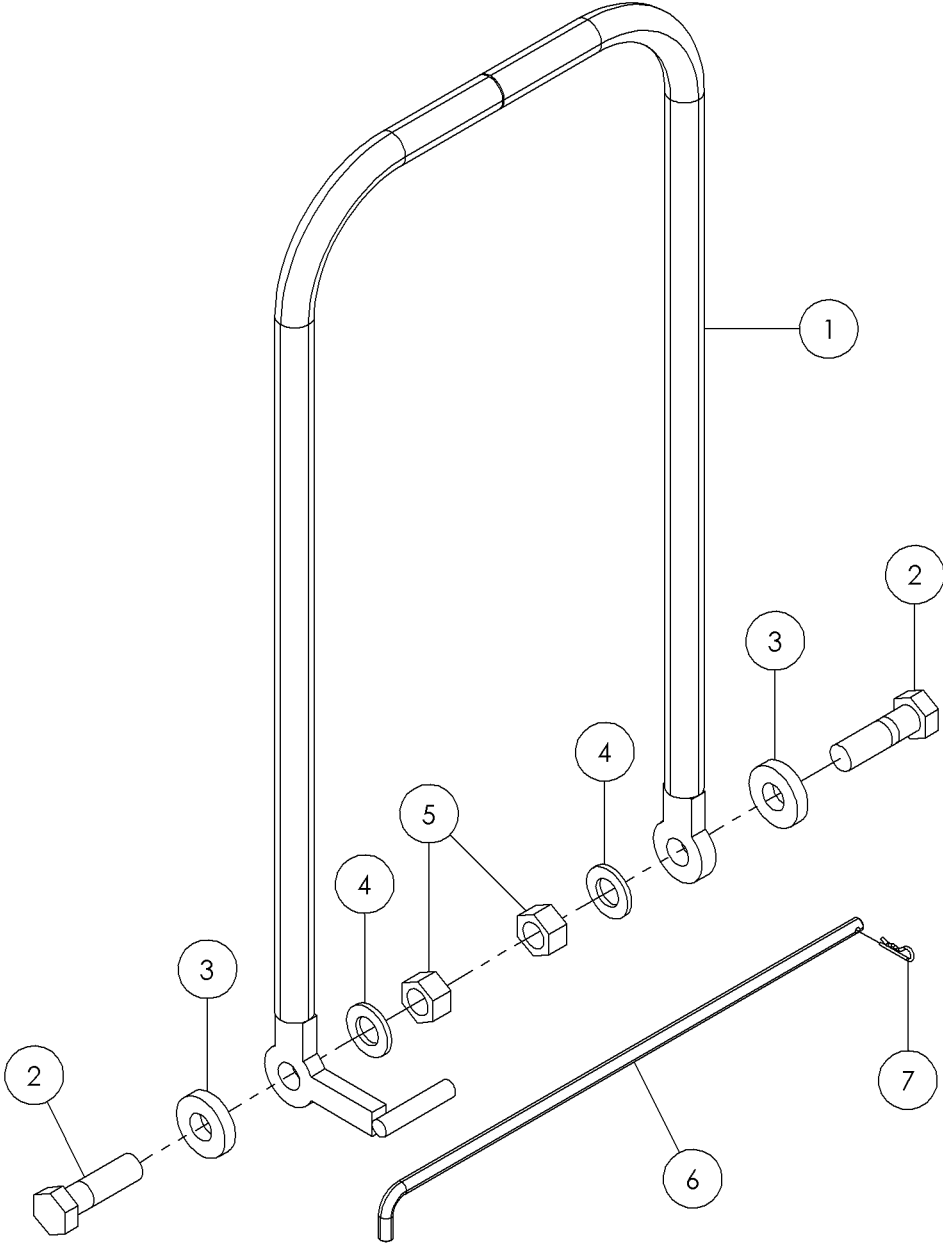
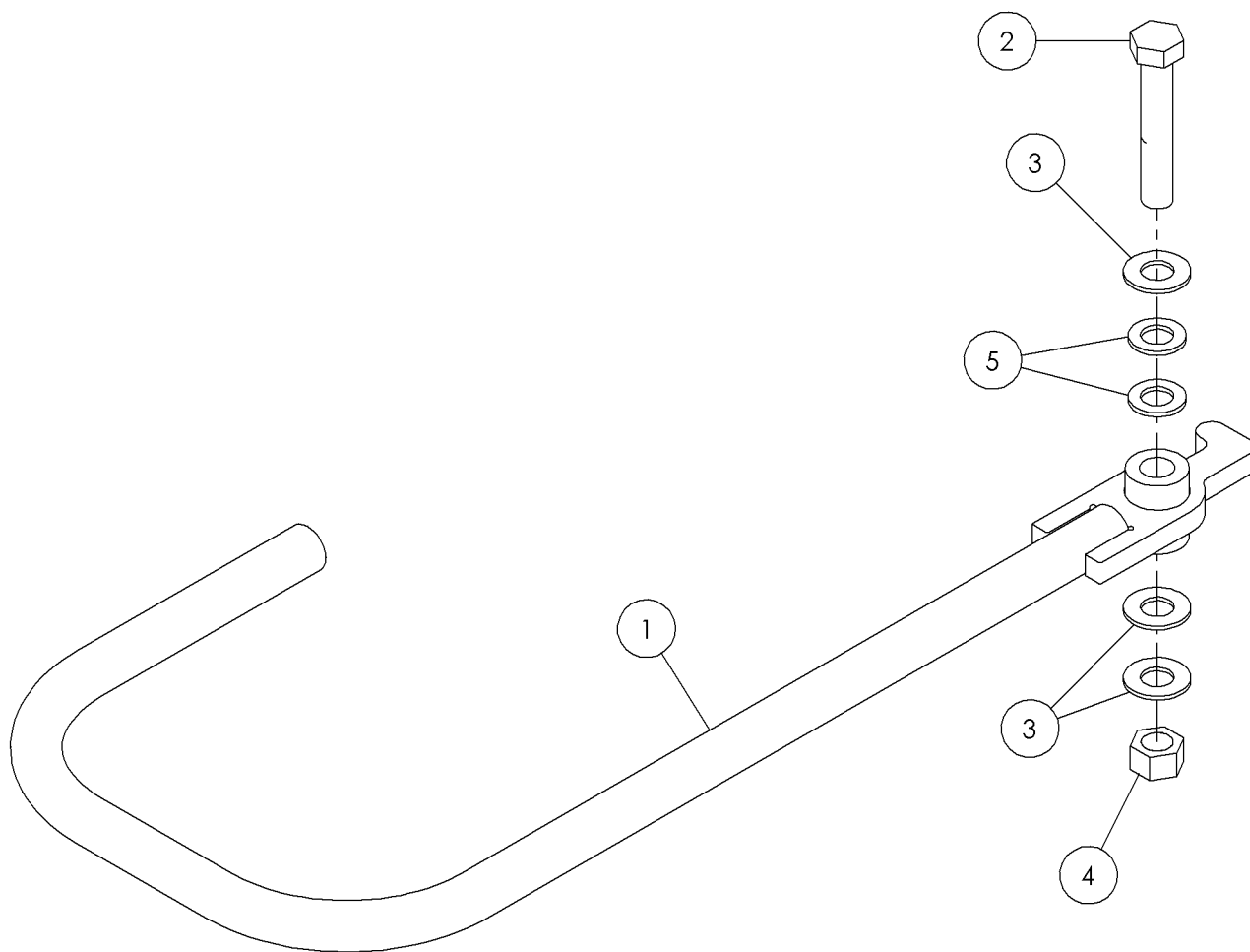

Illustration No. 296279894

## Guard Fig 8-3

REF. NO.	*	PART NO.	DESCRIPTION	QTY.	REMARKS
1		296275478	WELDMENT - ARM SAFETY GUARD	1	
2		238880001	BOLT-3/4-10X2 1/2 HHCS GR8 ZY	2	
3		276465001	TUBE - ARM SPACER	2	
4		235717001	WASHER - 3/4" HARDENED FLAT YZ	2	
5		250510001	NUT 3/4 NC Gr8 SLTL Y/ZINC	2	
6		276466001	BAR - ARM PIN	1	
7		1794007	HAIR PIN COTTER - .080 WIRE	1	

Safety Arm Fig 8-4





## Safety Arm Fig 8-4

REF. NO.	*	PART NO.	DESCRIPTION	QTY.	REMARKS
1		296287890	WELDMENT - SAFETY ARM	1	
2		238208001	BOLT 5/8 - 11 X 3 1/2 Gr 8 HEX ZYC	1	
3		235715001	WASHER-FLATSTRL-5/8" YZ A325	3	
4		250513001	NUT - 5/8NC Gr8 TOP LOCK Y/ZINC	1	
5		218386001	WASHER-BELLEVILL 1.13OD X.63ID	2	

Extend/Retract Arm Fig 8-5

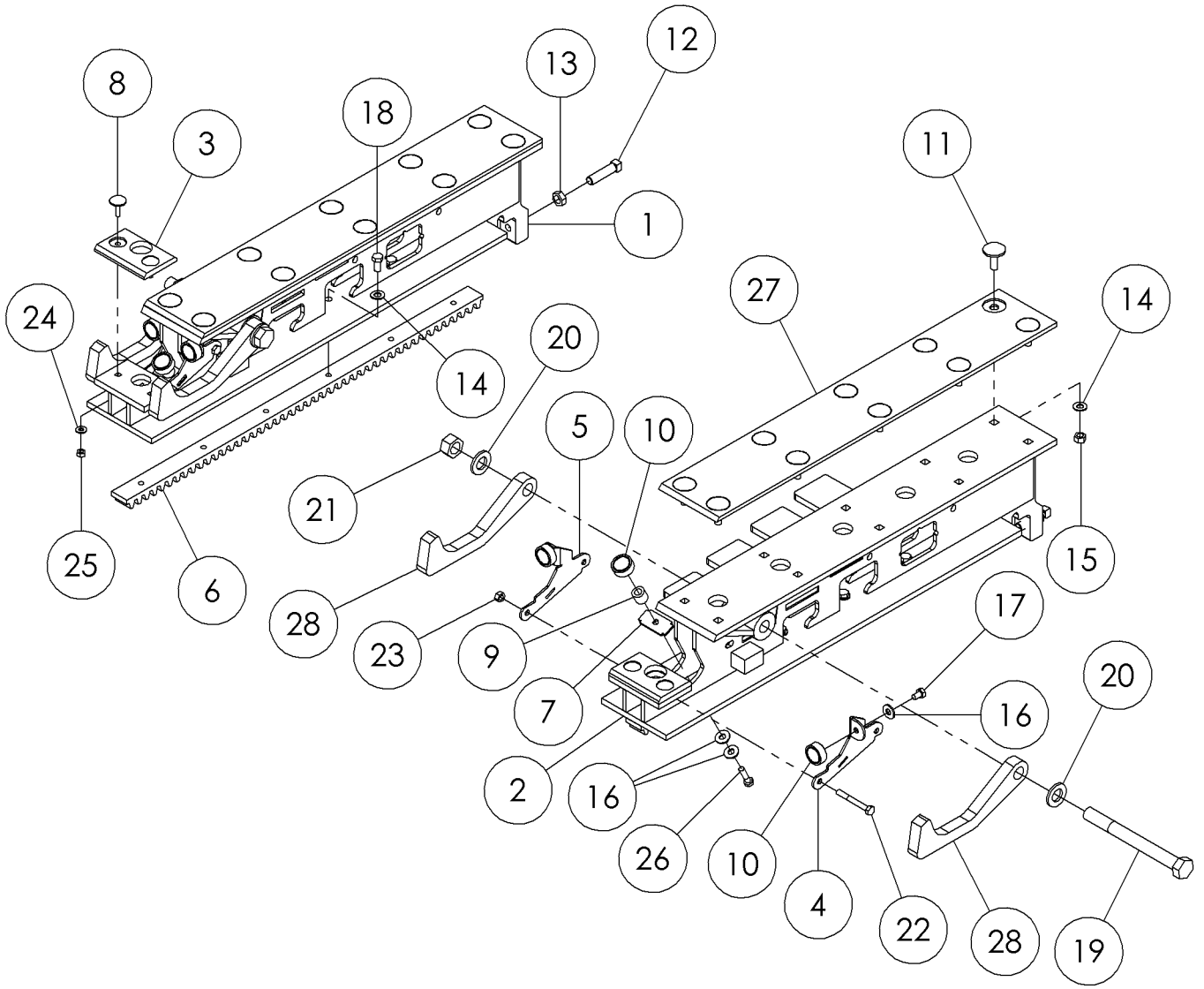

Illustration No. 296310794

## Extend/Retract Arm Fig 8-5

REF. NO.	*	PART NO.	DESCRIPTION	QTY.	REMARKS
1		296310899	WELDMNT - REAR ROD LOADER EXTEND/RETRACT	1	
2		296310896	FRONT ROD LOADER EXTEND/RETRACT WELDMNT	1	
3		277154001	BAR - WEAR	2	
4		296277002	PLATE - MAGNET MOUNT LH	2	
5		296277001	PLATE - MAGNET MOUNT RH	2	
6		296269730	GEAR - ROD LOADER SLIDER	2	
7		296277003	PLATE - MAGNET MOUNT SPACER	2	
8		276477001	BOLT - 1/4-20 X 1 ELEVATOR ZN PLT	4	
9		296277004	TUBE - MAGNET SPACER	2	
10		282642001	MAGNET - 1.25" ROD HOLDER	6	
11		601699012	3/8-16X1 1/4 ELEVATOR BOLT ZNC	20	
12		153752001	SQ HSS-1/2-13X2 ZP	2	
13		75383001	NUT-1/2-UNC GR.8 JAM HEX	2	
14		235713001	WASHER - FLATSTRL - .38 - .41 X .81 - .06-YA-A325	32	
15		250508001	NUT - 3/8-NC Gr8 TOP LOCK Y/ZINC	20	
16		510337605	WASHER-FLATSTD-.31-.38X.88-.08-YZ	8	
17		235740001	BOLT-5/16-18X1/2 GR8 ZYC	4	
18		235726001	BOLT-3/8-16X3/4 GR8 HEX ZNCPLT	12	
19		240344001	SCREW-HCS-.75-10X7.50-GR8-YZ	2	
20		235717001	WASHER - 3/4" HARDENED FLAT YZ	4	
21		250510001	NUT 3/4 NC Gr8 SLTL Y/ZINC	2	
22		248029001	BOLT-5/16-18X2 1/2 GR8 ZYC	4	
23		235741001	NUT - HEX - .31 - 18 - GR8 -YZ	4	
24		235716001	WASHER - FLATSTRL - .25 -.28 X .63 - .06 - CZ	4	
25		235732001	NUT - HEX - .25 - 20 - GR8 - YZ	4	
26		248031001	BOLT-5/16-18X1 1/4 GR8 ZYC	2	
27		296280090	PLATE - STRIP WEAR	2	
28		296310795	PLATE - ROD LOADER	4	

Rod Selector Fig 8-6

Illustration No. 296307463

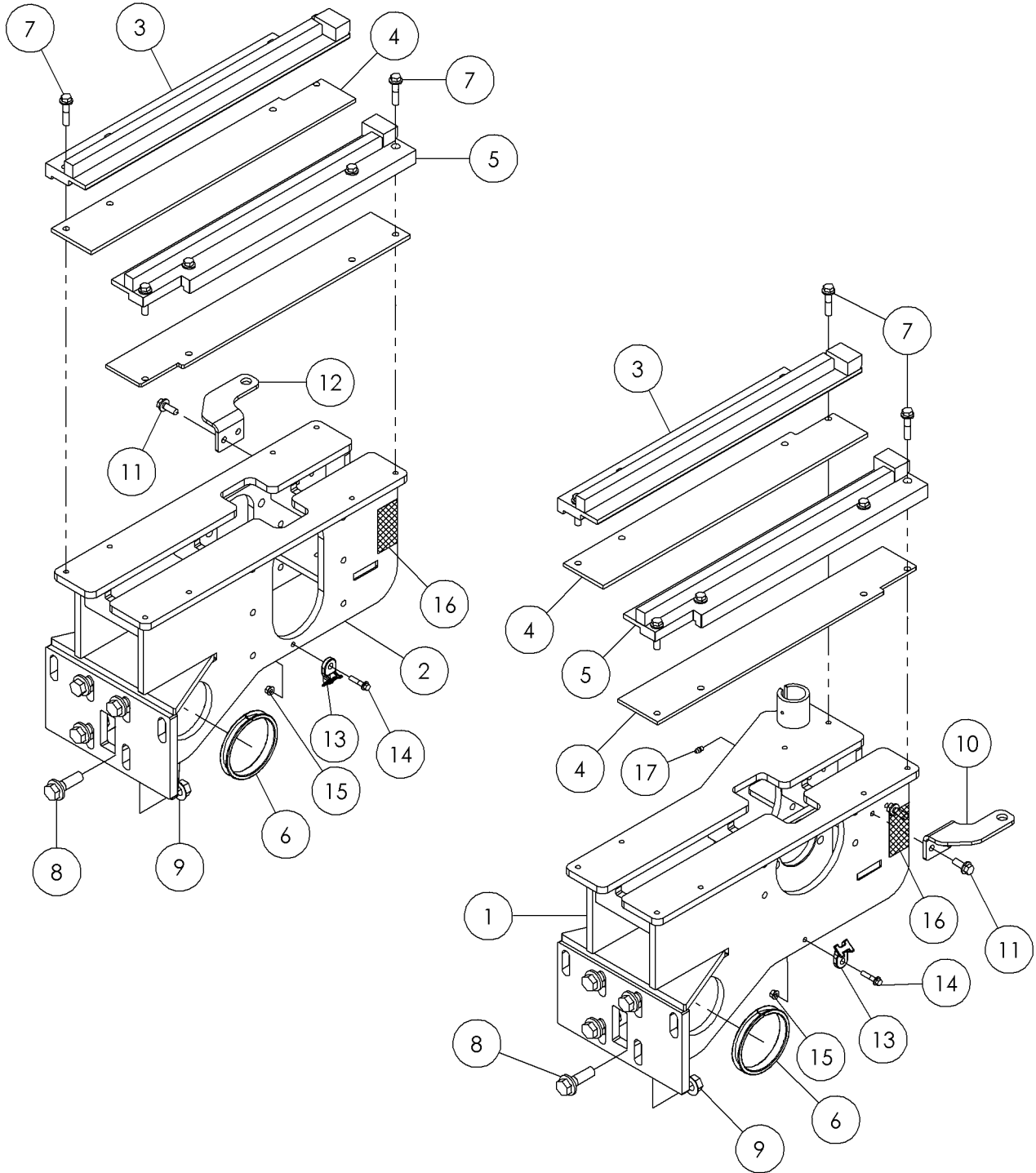

## Rod Selector Fig 8-6

REF. NO.	*	PART NO.	DESCRIPTION	QTY.	REMARKS
1		296307445	*WELDMENT - ROD LOADER MOUNT	1	
2		296307446	*WELDMENT - ROD LOADER MOUNT	1	
3		296307435	WELDMENT - COVER PLATE RIGHT	2	
4		296280063	STRIP - PLASTIC WEAR	4	
5		296307436	WELDMENT - COVER PLATE LEFT	2	
6		278774001	SEAL - EDGE 1/2" STYLE	4	
7		296300775	SCREW-HFS-..38-16X1.75-GR8-YZ	16	
8		296300802	SCREW-HFS-.63-11X2.00-GR8-YZ	8	
9		296300902	NUT-HEX FLG-.63-11-GR8-YZ	8	
10		296307456	PLATE - SAFETY BAR MOUNT, FRONT	1	
11		296300772	SCREW-HFS-..38-16X1.00-GR8-YZ	4	
12		296307457	PLATE - SAFETY BAR MOUNT, REAR	1	
13		296276018	MOUNT HELLER MANN TITON	2	
14		296300755	SCREW-HFS-.25-20X1.25-GRI-YZ	2	
15		510313401	NUT-HEXFLGL-.25-20-GR2-YZ	2	
16		7000a864	DECAL-WARNING DOMESTIC	4	Domestic
16		700IA864	DECAL - WARNING INTERNATIONAL	4	International
17		598001	FITTING-1/4" NF ST GREASE ZERK	1	

Rod Lift Cylinder Fig 8-7

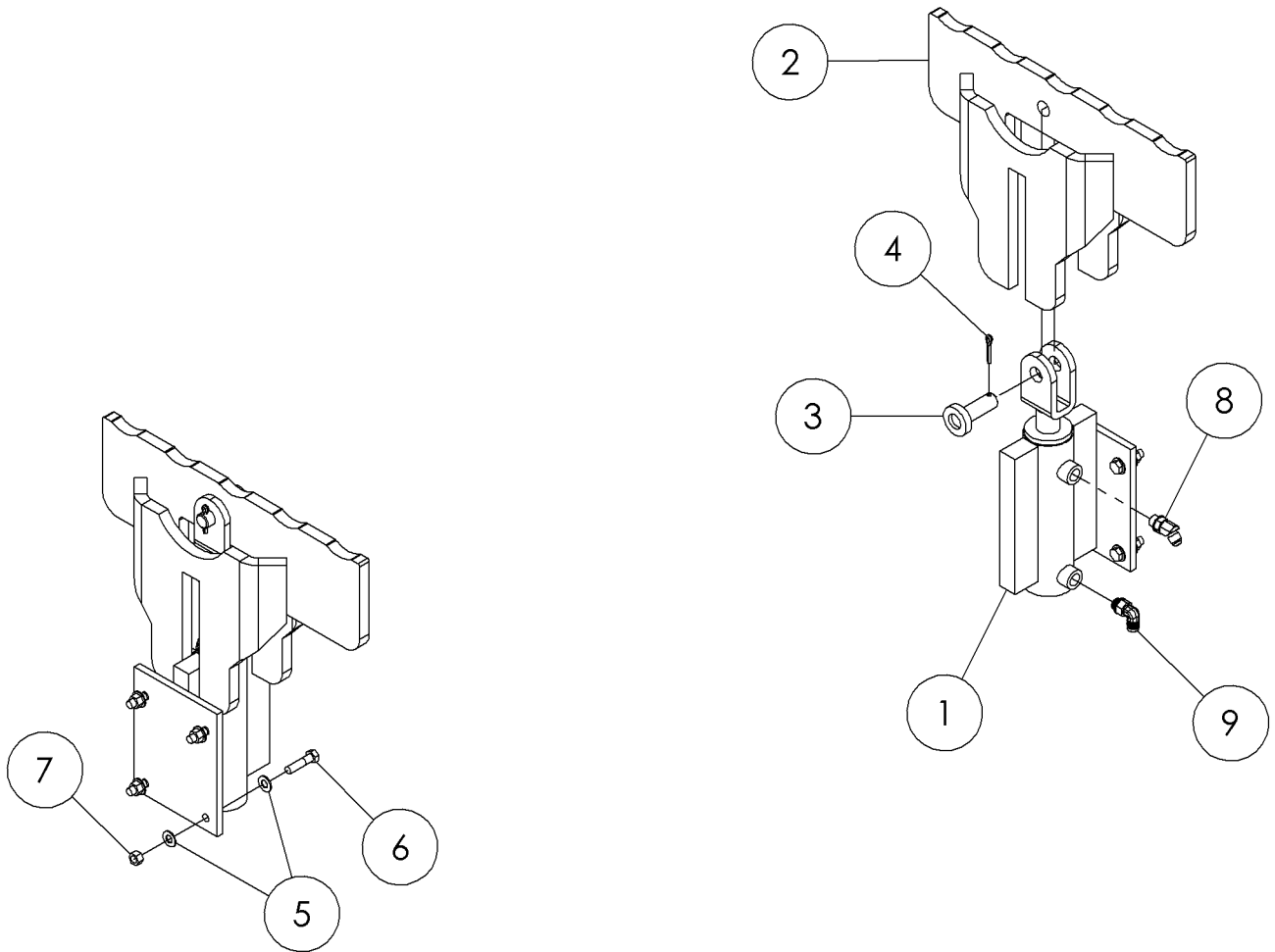
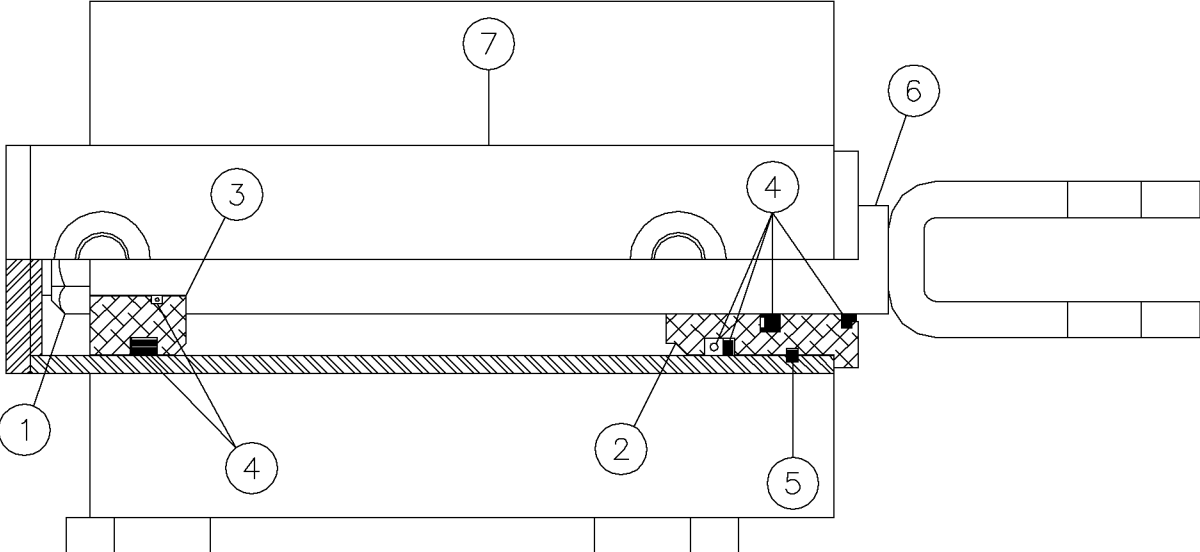

Illustration No. 296310790

## Rod Lift Cylinder Fig 8-7

REF. NO.	*	PART NO.	DESCRIPTION	QTY.	REMARKS
1		250494001	CYLINDER - 2 X 5"	1	
2		296310791	WELDMENT - ROD LIFT	2	
3		222815001	PIN-STEER CYLINDER	2	
4		510047	PIN - 3/16 X 1 1/4 COTTER	2	
5		235713001	WASHER-FLATSTRL-.38-.41X.81-.06-YA-A325	16	
6		235723001	SCREW - HCS -.38 - 16 X 1.50 - GR8 - YZ	8	
7		250508001	NUT - 3/8-NC Gr8 TOP LOCK Y/ZINC	8	
8		65563001	FITTING - 6M O-RING X 6M JIC 45 DEGREE	2	
9		59426001	FITTING - 90-6MJ-6MORBA	2	

Components-Rod Lift Cylinder Fig 8-7z01





## Components-Rod Lift Cylinder Fig 8-7z01

REF. NO.	*	PART NO.	DESCRIPTION	QTY.	REMARKS
1		230977003	NUT	1	
2		250494002	HEAD	1	
3		230977007	PISTON	1	
4		250494010	REPAIR KIT	1	
5		250494007	RETAINING RING	1	
6		250494008	SHAFT - (W/ CLEVIS)	1	
7		250494009	BARREL (W/ CLEVIS & PORTS)	1	
		250494001	CYLINDER - 2 X 5"		(Inc. All Items In Figure.)

Valve Rod Loader Fig 8-8

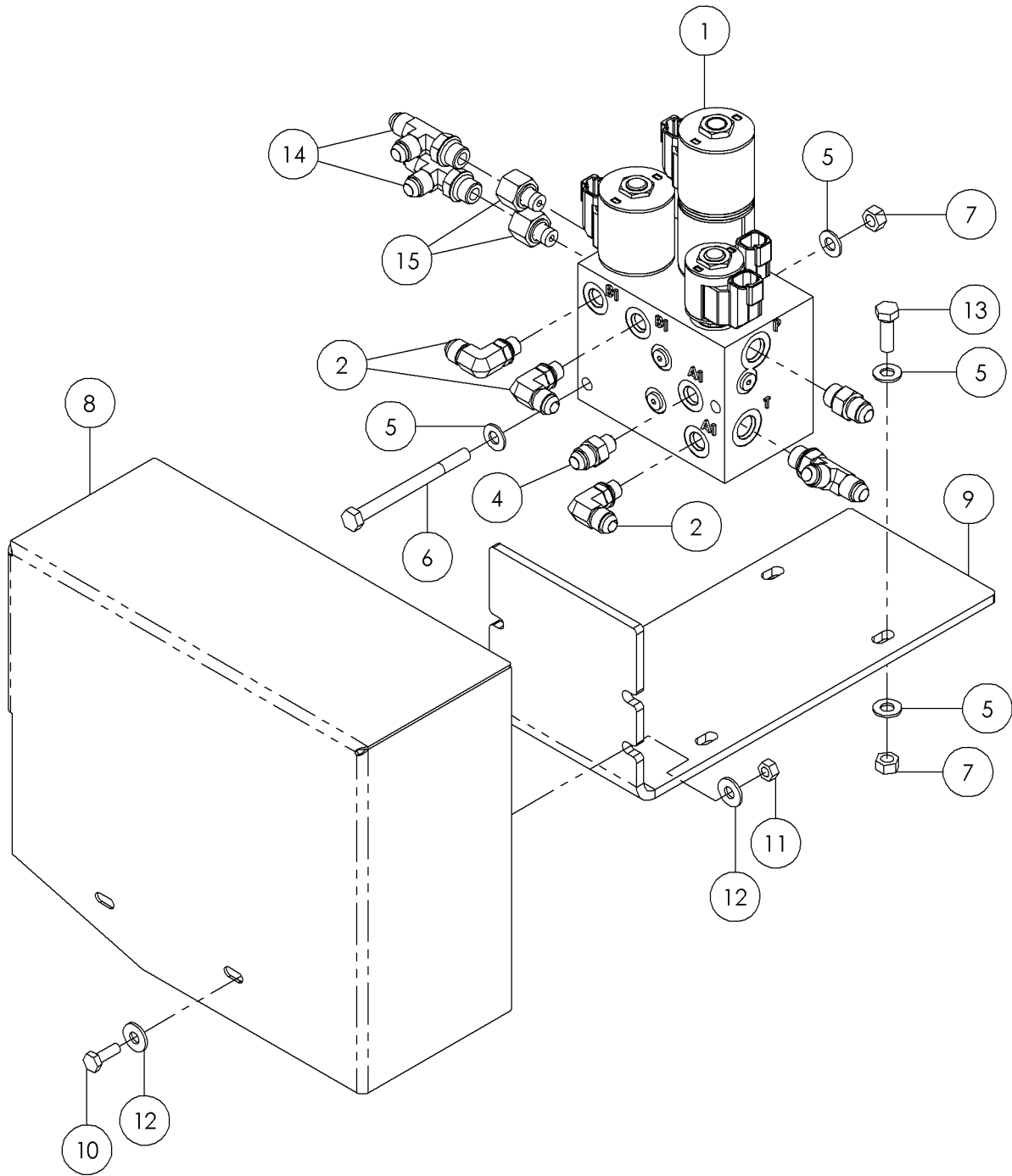
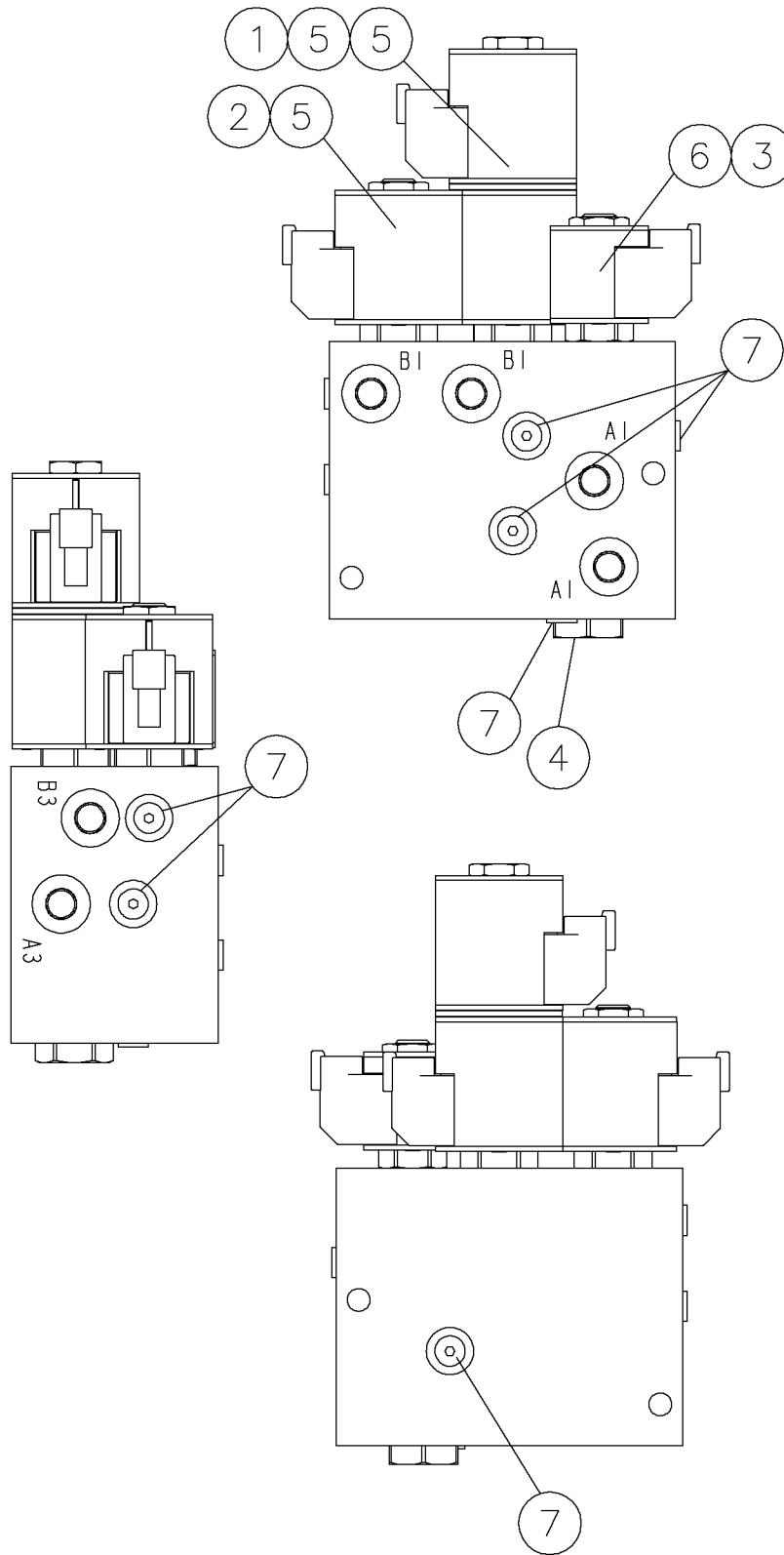

Illustration No. 296280973

## Valve Rod Loader Fig 8-8

REF. NO.	*	PART NO.	DESCRIPTION	QTY.	REMARKS
1		296269662	MANIFOLD - ROD LOADER	1	Breakdown Fig. 8-8z01
2		60906001	4MX6M JIC 90 DEG ELBOW	3	
3		65565001	FITTING - 6M O-RING X 6M JIC ST.	1	
4		65569001	FITTING STR 6MJ - 4MORB	1	
5		235714001	WASHER-FLATSTRL-.31-.34X.69-.06-YZ-A325	8	
6		250503001	BOLT 5/16 - 18 X 3 3/4 Gr8 HEX	2	
7		235741001	NUT - HEX - .31 - 18 - GR8 - YZ	4	
8		296307360	SHIELD - ROD LOADER VALVE	1	
9		296280972	BRACKET - ROD LOADER VALVE	1	
10		235734001	BOLT-1/4-20X3/4 GR8 ZYC	2	
11		235732001	NUT - HEX - .25 - 20 - GR8 - YZ	2	
12		510337603	WASHER-FLATSTD-.25-.31X.75-.07-YZ	4	
13		238209001	BOLT-5/16-18X1 GR8 HEX ZINC YC	2	
14		68774001	FITTING-6MX6M JIC (RUN)X6M JIC	3	
15		88530001	FITTING-4MORB X 6FORB SOLID REDUCER	2	

Components-Valve Fig 8-8z01



Components-Valve Fig 8-8z01

REF. NO.	*	PART NO.	DESCRIPTION	QTY.	REMARKS
1		296272927	SOLENOID VALVE	1	
1		296265599	SEAL KIT	1	
1		244725007	NUT - COIL	1	
2		296265596	CARTRIDGE - SOLENOID VALVE	1	
2		296265599	SEAL KIT	1	
2		244725007	NUT - COIL	1	
3		296285067	CARTRIDGE	1	
3		296265599	SEAL KIT	1	
3		244725007	NUT - COIL	1	
4		296272929	FLOW DIVIDER	1	
5		296271077	COILS	3	
6		245016003	ORIFICE DISC	1	
7		240324015	PLUG-SAE	1	
		296269662	MANIFOLD - ROD LOADER		(Inc. All Items in Figure)

Row Selector Fig 8-9

Illustration No. 296307468

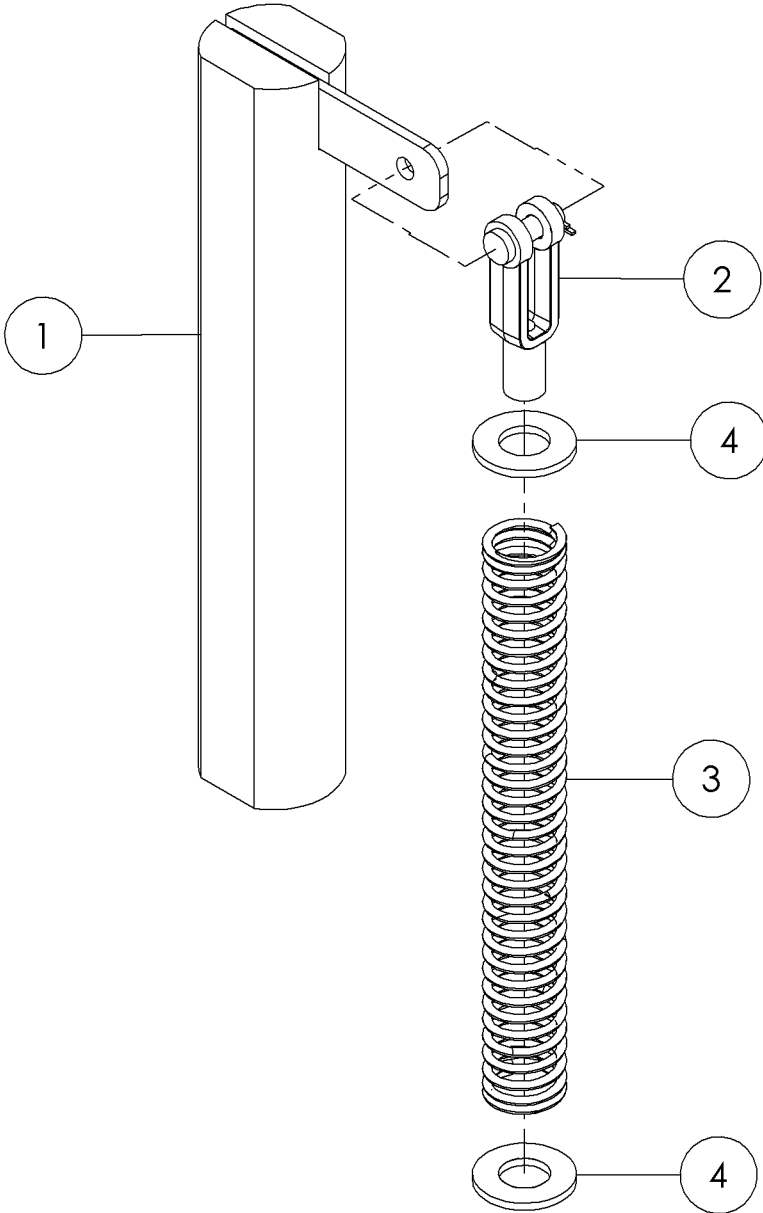

## Row Selector Fig 8-9

REF. NO.	*	PART NO.	DESCRIPTION	QTY.	REMARKS
1		296307466	WELD - SELECTOR ARM	1	
2		296289038	CLEVIS - 029025 40 SERIES	1	
3		296283300	SPRING - .859 OD X 9.00	1	
4		485025	WASHER-1/2 FLAT-HARDENED-YZ	2	

Row Selector Control Box Fig 8-10

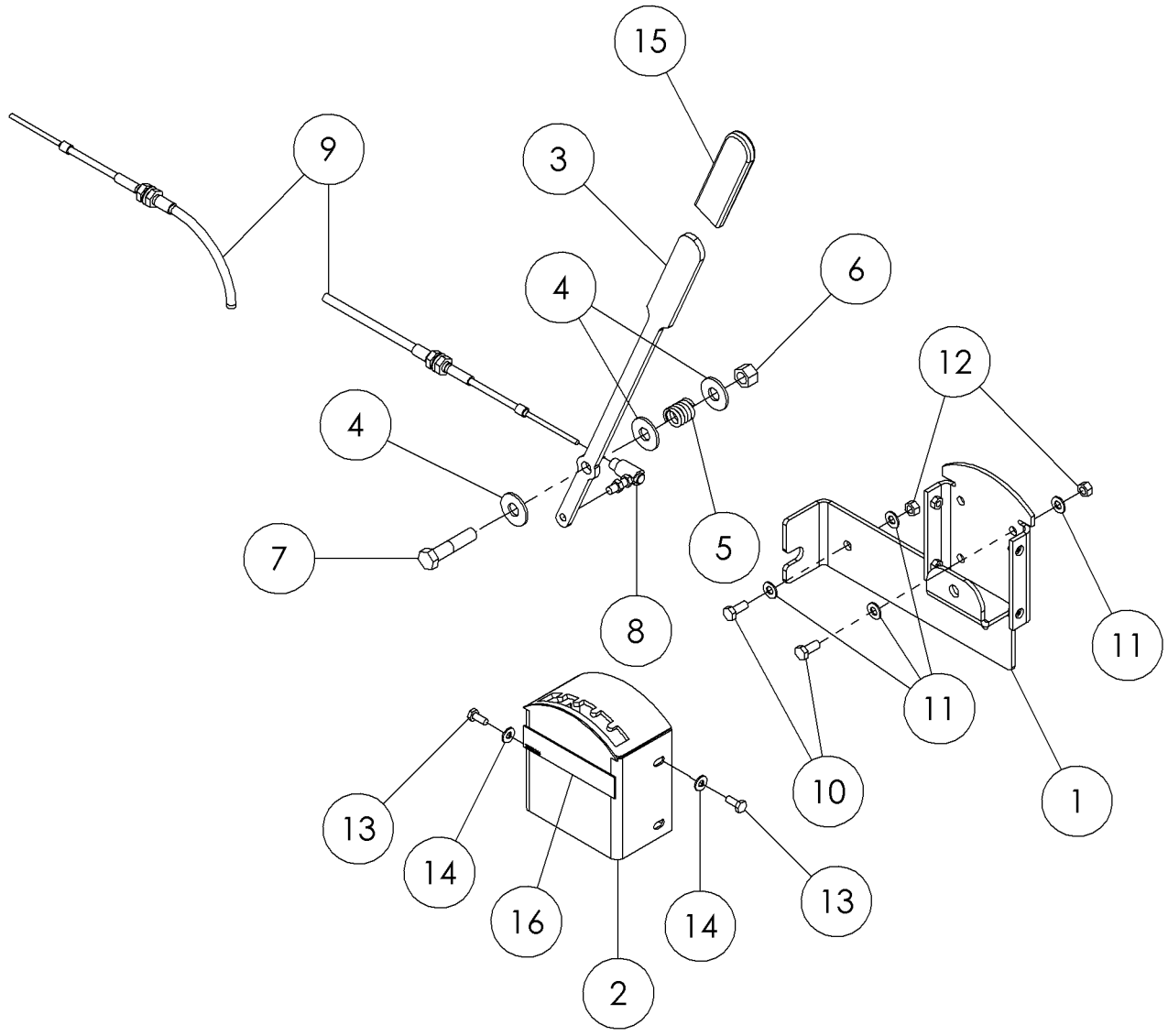

Illustration No. 296280445



## Row Selector Control Box Fig 8-10

REF. NO.	*	PART NO.	DESCRIPTION	QTY.	REMARKS
1		296289010	WELDMENT - HANDLE BASE MOUNT	1	
2		296289011	WELDMENT - HANDLE COVER	1	
3		296280448	PLATE - HANDLE	1	
4		510337611	WASHER-FLATSTD-.50-.56X1.38-.11-YZ	3	
5		285776001	SPRING - COMP #49 1.00 O.A.	1	
6		510317501	NUT-TLHEX-.50-13-B-YZ	1	
7		240335001	SCREW-HCS-.50-13X2.25-GR8-YZ	1	
8		78653001	BALL JOINT 1/4FX5/16M A032267	1	
9		296289014	CABLE 314-LTT-3-204	1	
10		235742001	BOLT-5/16-18X3/4 GR8 ZYC	6	
11		235714001	WASHER-FLATSTRL-.31-.34X.69-.06-YZ-A325	12	
12		235741001	NUT - HEX - .31 - 18 - GR8 -YZ	6	
13		284944001	SOCKET HD CAPSCREW - 1/4 - 20 UNC X 5/8	4	
14		235716001	WASHER-FLATSTRL-.25-.28X.63-.06 - CZ	4	
15		258768001	HANDLE-PLASTIC (YELLOW)	1	
16		700ID254	DECAL - ROW SELECTOR	1	

Rod Box-10' (250 FT.) Fig 8-11

Illustration No. 296310871

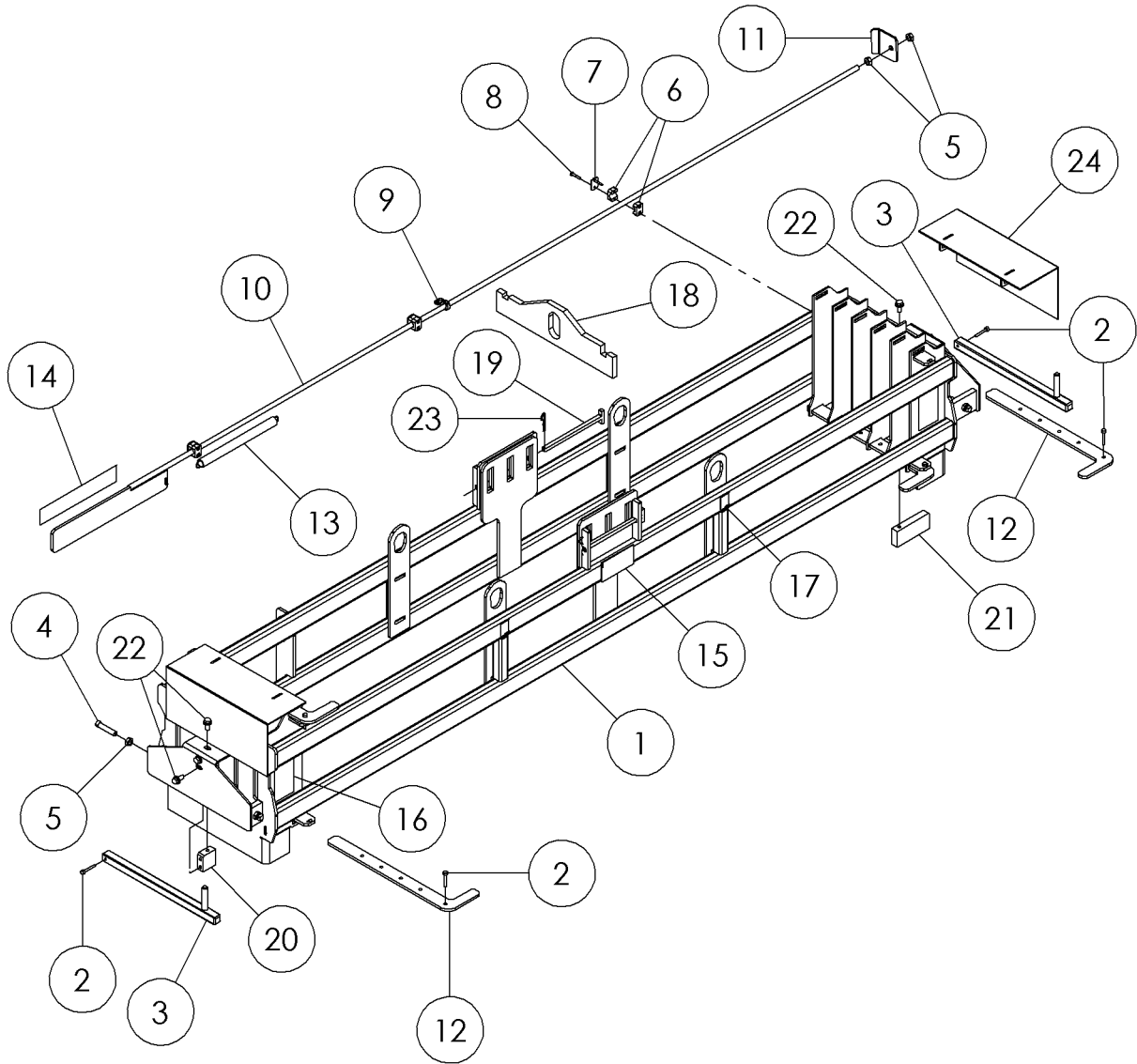

## Rod Box-10' (250 FT.) Fig 8-11

REF. NO.	*	PART NO.	DESCRIPTION	QTY.	REMARKS
1			ROD BOX WELDMENT 10FT	1	Not Sold Separately
2		2108001	LYNCH PIN - 1/4 X 2	6	
3		296280023	PIN - ROD BOX	2	
4		551030	SQ HSS-5/8-11X3	4	
5		250514001	NUT -5/8NC JAM Y/ZINC	6	
6		279817001	CLAMP - HOSE 2180PP	6	
7		903135005	PLATE-COVER COP-2	3	
8		238210001	BOLT - 1/4-20X1 1/2 GR8 HEX ZYC	6	
9		295529001	MOUNT-ROD INDICATOR SPRING	1	
10		296280100	WELDMENT - ROD POSITION MARKER	1	
11		296279747	PLATE - FLAG STOP	1	
12		296310782	PLATE - ROD RETAINER	4	
13		1789001	SPRING-1 1/8ODX15/16ID X 15 EXT REF	1	
14		700IA997	DECAL - GEARBOX POSITION	1	
15		70000563	DECAL-WARNING (UND)	2	Domestic
15		7000I563	DECAL-WARNING (UND)	2	International
16		7000A627	DECAL-DANGER	4	Domestic
16		700IA627	DECAL-DANGER	4	International
17		7000I445	DECAL-LIFT POINT	5	
18		296303202	BAR - LIFT	1	
19		296303144	BAR - KEEPER	2	
20		296303095	BLOCK - CENTERING	1	
21		296303102	BAR - CENTERING	1	
22		296300788	SCREW-HFS-.50-13X1.00GR8-YZ	6	
23		1794003	HAIR PIN COTTER - .148 WIRE	2	
24		296335016	ROD COVER	2	
		296278250	ROD BOX/DECAL - 2.625"X 10' FSI (DOMESTIC)		Inc. 1 Of Ref. 1, 2 Of Ref. 15, 4 Of Ref. 16&17
		296319501	ROD BOX/DECAL - 2.625" X 10' FSI (INTERNATIONAL)		Inc. 1 Of Ref. 1, 2 Of Ref. 15, 4 Of Ref. 16&17

Rod Box-10' (500 FT.) Fig 8-12

Illustration No. 296308607

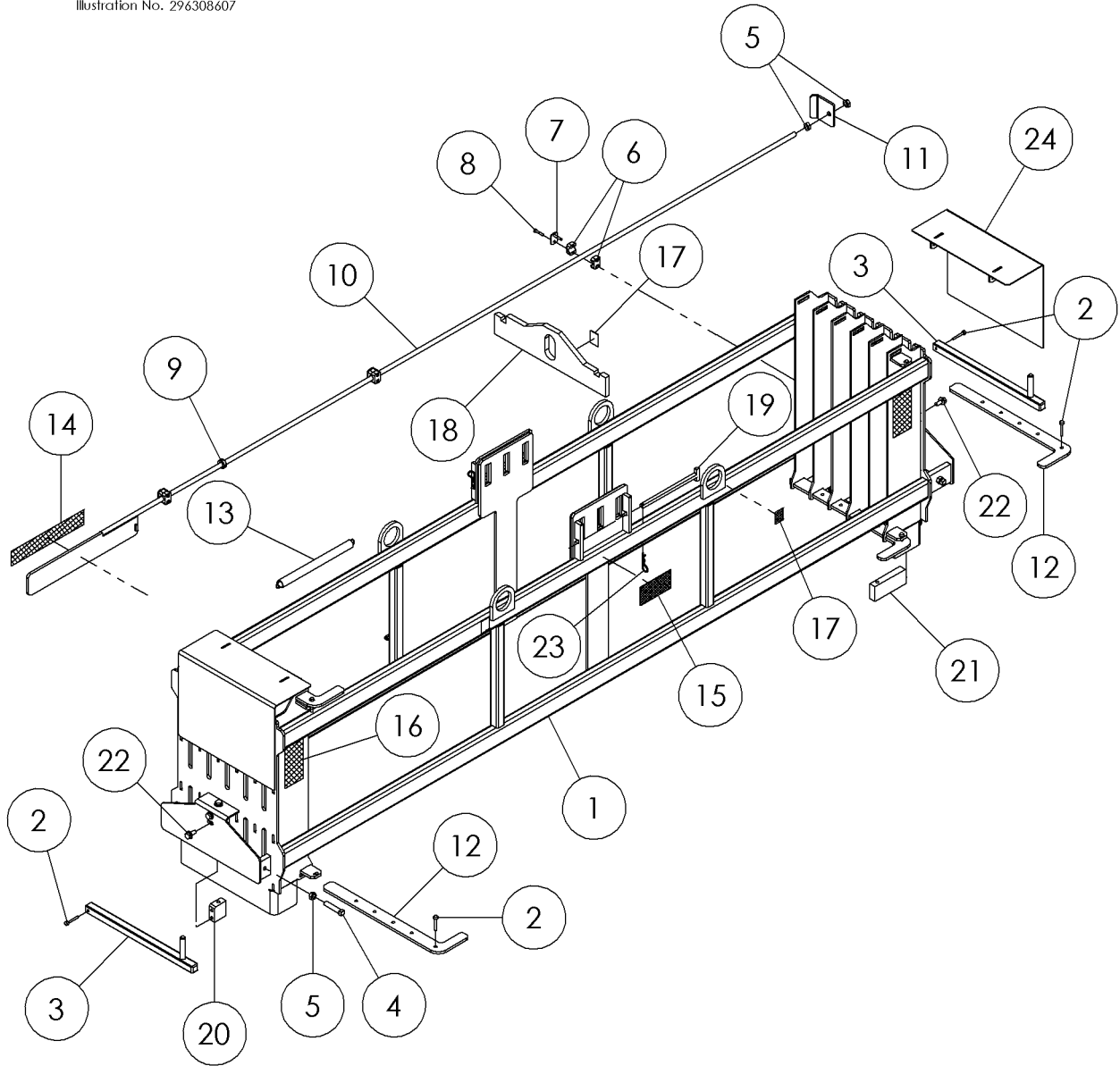

## Rod Box-10' (500 FT.) Fig 8-12

REF. NO.	*	PART NO.	DESCRIPTION	QTY.	REMARKS
1		296310785	ROD BOX WELDMENT 10FT	1	Not Sold Separately
2		2108001	LYNCH PIN - 1/4 X 2	6	
3		296280023	PIN - ROD BOX	2	
4		551030	SQ HSS-5/8-11X3	4	
5		250514001	NUT -5/8NC JAM Y/ZINC	6	
6		279817001	CLAMP - HOSE 2180PP	6	
7		903135005	PLATE-COVER COP-2	3	
8		238210001	BOLT - 1/4-20X1 1/2 GR8 HEX ZYC	6	
9		295529001	MOUNT-ROD INDICATOR SPRING	1	
10		296280100	WELDMENT - ROD POSITION MARKER	1	
11		296279747	PLATE - FLAG STOP	1	
12		296310782	PLATE - ROD RETAINER	4	
13		1789001	SPRING-1 1/8ODX15/16ID X 15 EXT REF	1	
14		700IA997	DECAL - GEARBOX POSITION	1	
15		70000563	DECAL-WARNING (UND)	2	Domestic
15		7000I563	DECAL-WARNING (UND)	2	International
16		7000A627	DECAL-DANGER	4	Domestic
16		700IA627	DECAL-DANGER	4	International
17		7000I445	DECAL-LIFT POINT	5	
18		296303202	BAR - LIFT	1	
19		296303144	BAR - KEEPER	2	
20		296303095	BLOCK - CENTERING	1	
21		296303102	BAR - CENTERING	1	
22		296300788	SCREW-HFS-.50-13X1.00GR8-YZ	6	
23		1794003	HAIR PIN COTTER - .148 WIRE	2	
24		296335013	ROD END COVER	2	
		296278246	ROD BOX/DECAL - DOMESTIC (10')		Inc. 1 Of Ref.1, 2 Of Ref. 15, 4 Of Ref. 16&17
		296278247	ROD BOX/DECAL - INTERNATIONAL (10')		Inc. 1 Of Ref.1, 2 Of Ref. 15, 4 Of Ref. 16&17

Rod Box-15' (300 FT.) Fig 8-13

Illustration No. 296310882

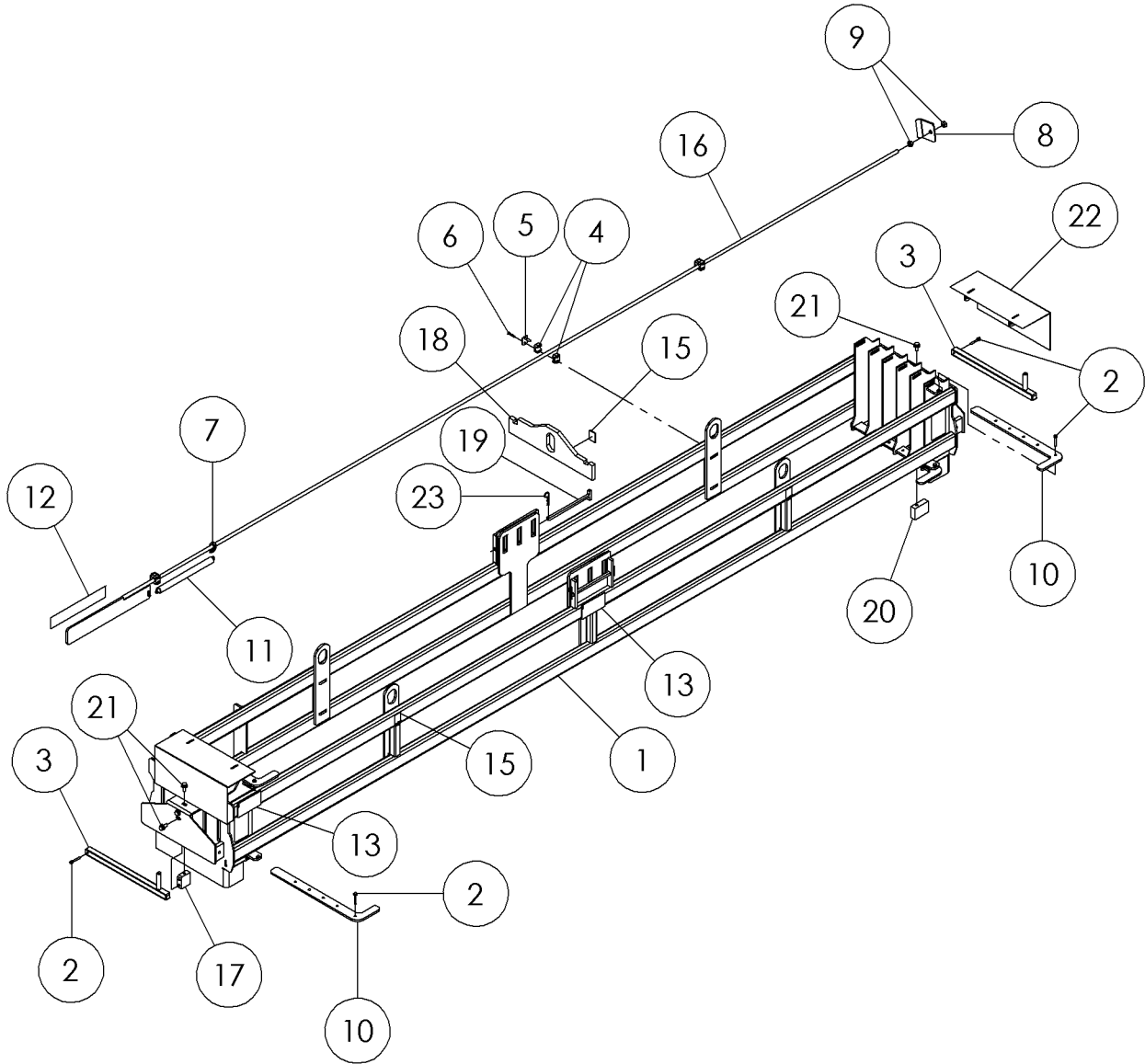

## Rod Box-15' (300 FT.) Fig 8-13

REF. NO.	*	PART NO.	DESCRIPTION	QTY.	REMARKS
1			ROD BOX WELDMENT 15FT	1	Not Sold Separately
2		2108001	LYNCH PIN - 1/4 X 2	6	
3		296280023	PIN - ROD BOX	2	
4		279817001	CLAMP - HOSE 2180PP	6	
5		903135005	PLATE-COVER COP-2	3	
6		238210001	BOLT - 1/4-20X1 1/2 GR8 HEX ZYC	6	
7		295529001	MOUNT-ROD INDICATOR SPRING	1	
8		296279747	PLATE - FLAG STOP	1	
9		250514001	NUT -5/8NC JAM Y/ZINC	2	
10		296310782	PLATE - ROD RETAINER	4	
11		1789001	SPRING-1 1/8ODX15/16ID X 15 EXT REF	1	
12		700IA997	DECAL - GEARBOX POSITION	1	
13		70000563	DECAL-WARNING (UND)	3	Domestic
13		7000I563	DECAL-WARNING (UND)	3	International
14		7000A627	DECAL-DANGER	4	Domestic
14		700IA627	DECAL-DANGER	4	International
15		7000I445	DECAL-LIFT POINT	5	
16		296280168	WELDMENT - ROD POSITION MARKER	1	
17		296303095	BLOCK - CENTERING	1	
18		296303202	BAR - LIFT	1	
19		296303144	BAR - KEEPER	2	
20		296303096	BLOCK - CENTERING	1	
21		296300788	SCREW-HFS-.50-13X1.00GR8-YZ	6	
22		296335016	ROD COVER	2	
23		1794003	HAIR PIN COTTER - .148 WIRE	2	
		296319502	ROD BOX/DECAL - 2.625" X 15' FSI (DOMESTIC)		Inc. 1 Of Ref. 1, 3 Of Ref. 13, 4 Of Ref. 14&15
		296319503	ROD BOX/DECAL - 2.625" X 15' FSI (INTERNATIONAL)		Inc. 1 Of Ref. 1, 3 Of Ref. 13, 4 Of Ref. 14&15

Rod Box-15' (600 FT.) Fig 8-14

Illustration No. 296308608

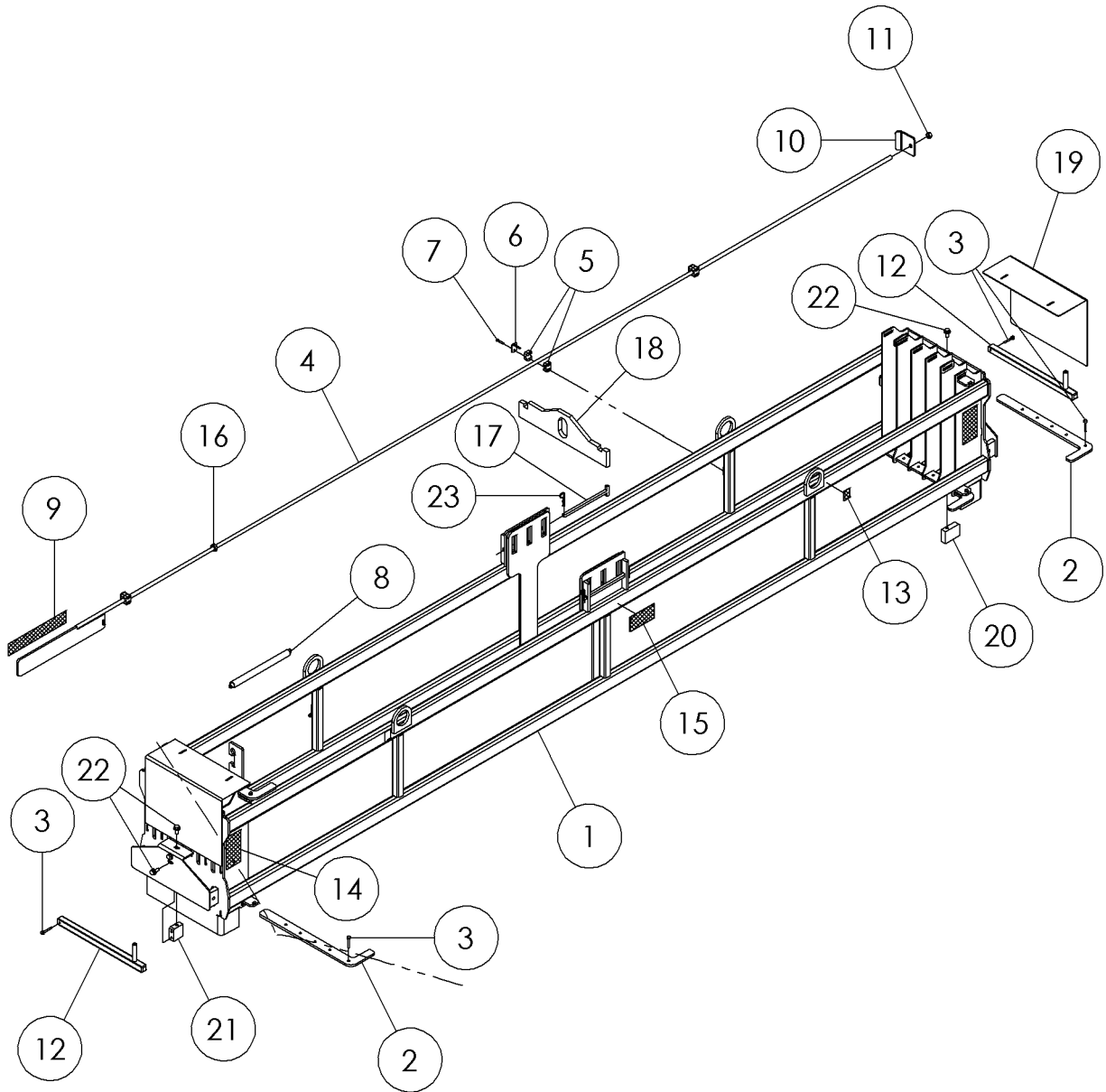



## Rod Box-15' (600 FT.) Fig 8-14

REF. NO.	*	PART NO.	DESCRIPTION	QTY.	REMARKS
1			ROD BOX WELDMENT	1	Not Sold Separately
2		296310782	PLATE - ROD RETAINER	4	
3		2108001	LYNCH PIN - 1/4 X 2	6	
4		296280168	WELDMENT - ROD POSITION MARKER	1	
5		279817001	CLAMP - HOSE 2180PP	6	
6		903135005	PLATE-COVER COP-2	3	
7		238210001	BOLT - 1/4-20X1 1/2 GR8 HEX ZYC	6	
8		1789001	SPRING-1 1/8ODX15/16ID X 15 EXT REF	1	
9		700ia997	DECAL - GEARBOX POSITION	1	
10		296279747	PLATE - FLAG STOP	1	
11		250514001	NUT -5/8NC JAM Y/ZINC	1	
12		296280023	PIN - ROD BOX	2	
13		7000I445	DECAL-LIFT POINT	5	
14		7000A627	DECAL-DANGER	4	Domestic
14		700IA627	DECAL-DANGER	4	International
15		70000563	DECAL-WARNING (UND)	2	Domestic
15		7000I563	DECAL-WARNING (UND)	2	International
16		295529001	MOUNT-ROD INDICATOR SPRING	1	
17		296303144	BAR - KEEPER	2	
18		296303202	BAR - LIFT	1	
19		296335013	ROD END COVER	2	
20		296303096	BLOCK - CENTERING	1	
21		296303095	BLOCK - CENTERING	1	
22		296300788	SCREW-HFS-.50-13X1.00GR8-YZ	6	
23		1794003	HAIR PIN COTTER - .148 WIRE	2	
		296278248	ROD BOX/DECAL - DOMESTIC (15')		Inc. 1 Of Ref. 1, 2 Of Ref. 15, 4 Of Ref. 13&14
		296278249	ROD BOX/DECAL - INTERNATIONAL (15')		Inc. 1 Of Ref. 1, 2 Of Ref. 15, 4 Of Ref. 13&14

Electrical-Operator Controls Fig 9-1

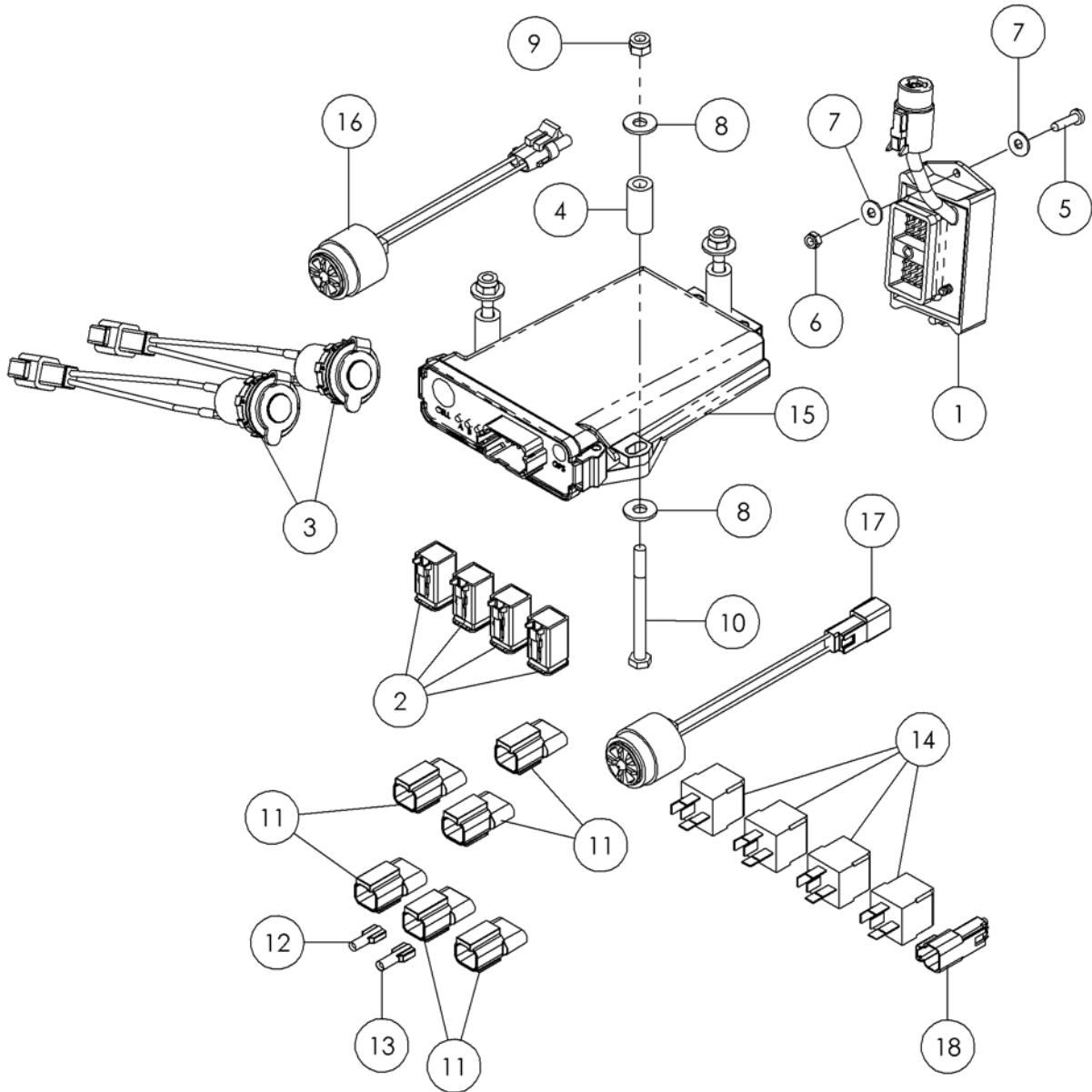

Illustration No. 296279952

## Electrical-Operator Controls Fig 9-1

REF. NO.	*	PART NO.	DESCRIPTION	QTY.	REMARKS
1		281526001	BUSS BAR MODULE	1	
2		282531001	MODULE - DEUTSCH DT06-6S 3AMP DIODE	4	
3		154677001	OUTLET - 12 VOLT	2	
4		296307438	RD/TB - .563 O.D. X .125W X 1.188	3	
5		1802006	BOLT-10-24 X 3/4 RND HD STOVE	2	
6		99042001	NUT - NYLOCK - 10 - 24 - GR2 - CZ	2	
7		485001	WASHER - FLATSTD - .19 - .22 X .56 - .05 - CZ	4	
8		510337603	WASHER-FLATSTD-.25-.31X.75-.07-YZ	6	
9		103201001	NUT-1/4-20NC NYLON INSERT LOCK	3	
10		503530001	BOLT-1/4 NC X 3 GR8 HEX	3	
11		296269610	MODULE-DEUTSCH DT04-4P 3AMP DIODE	6	
12		18988001	TERM-.250FULL INS MALE SLD16GA	1	
13		18989001	TERM-.250 FULL INS FEM SLD16GA	1	
14		296286772	CONTROL RELAY - 12V,40.30 AMP, SPDT	4	
15		296270163	ASM, STRIKEALERT BLANK	1	
16		286920001	REMOTE LOCKOUT BUZZER	1	
17		296292078	HORN - ZAP ALERT DEUTSCH 2 PIN	1	
18		296286486	RECEPTACLE W/SEAL PLUGS- DT04-2P	1	

Upper LH Panel Fig 9-2

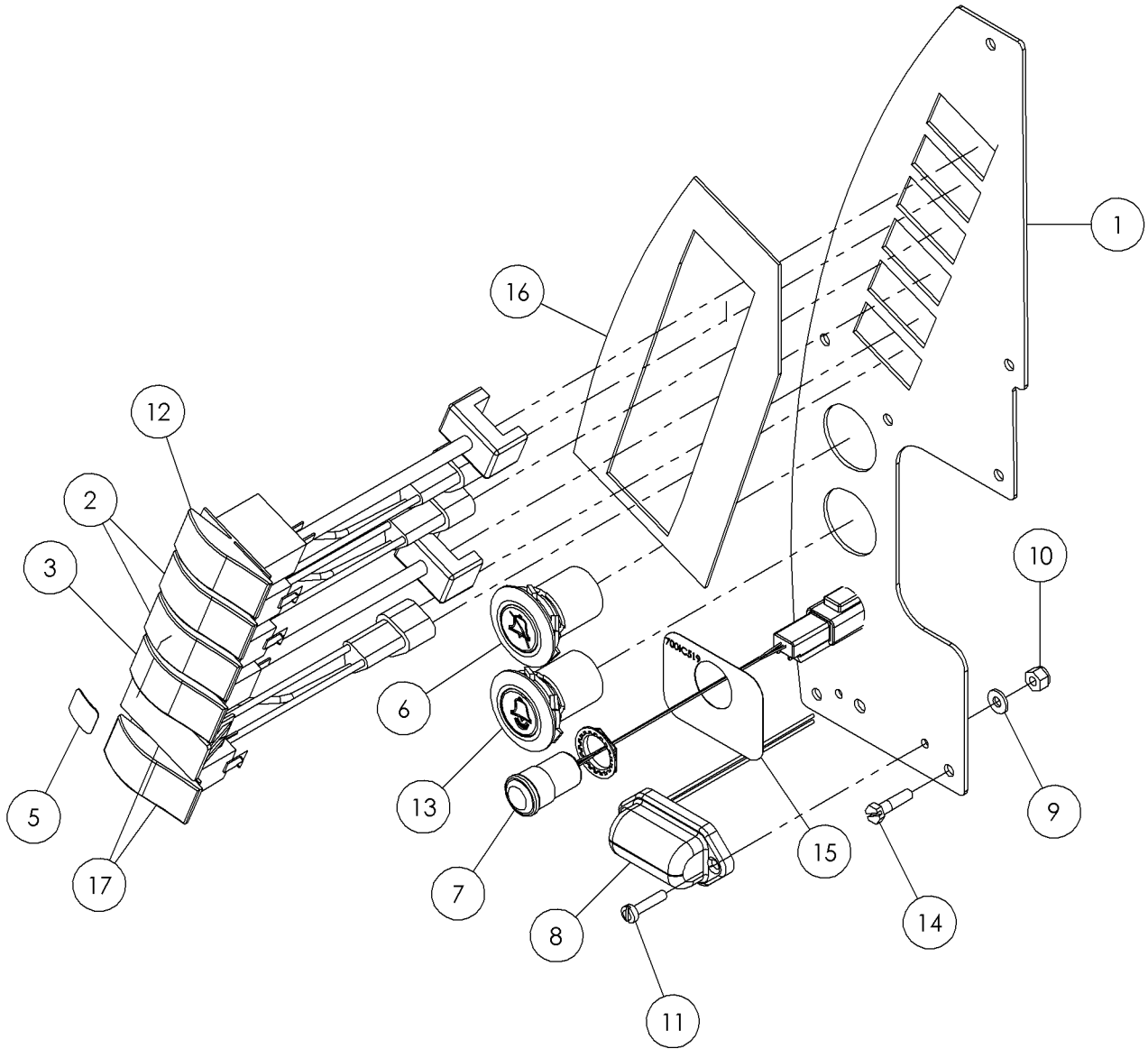

Illustration No. 296279938

## Upper LH Panel Fig 9-2

REF. NO.	*	PART NO.	DESCRIPTION	QTY.	REMARKS
1		296274139	PLATE - SWITCH LEFT	1	
2		257205001	SWITCH-SP 2 POSITION	2	(Wash Wand/Drill Fluid)(High/Low Pressure)
3		296269576	SWITCH - ON/ON/ON	1	Drill Mode Selection
4		257541001	SWITCH-SPDT 3 POSITION MOM	1	Rear Stabilizer
5		700IC454	DECAL - CONTROL	1	
6		296280268	SWITCH-PUSH BUTTON STRK ALERT ALARM OFF	1	Alarm Cancel
7		296275581	LIGHT - REMOTE LOCKOUT-GREEN	1	Green Indicator Light
8		296256067	LIGHT - CONSOLE, M434	1	
9		224769001	WASHER-#8 FLAT	2	
10		69759001	LOCK NUT-#8-32 NYLON INSERT PL	2	
11		10530006	SCREW-#8-32X3/4 SLOT RD.HD.	2	
12		296274146	SWITCH - SP 3 POSITION	1	3-Speed Gearbox
13		296280273	SWITCH - PUSH BUTTON STRIKE ALERT TEST	1	Strike Alert Test
14		510357010	SCREW-MCH-10-24X.75-GR2-YZ-HWH- SLOTTED	7	
15		700IC519	DECAL - STRIKE ALERT GREEN LIGHT	1	
16		700IC348	DECAL - CONTROL LEFT HAND	1	
17		156720001	PLUG - ROCKER SWITCH	1	

Left Joystick Panel Fig 9-3

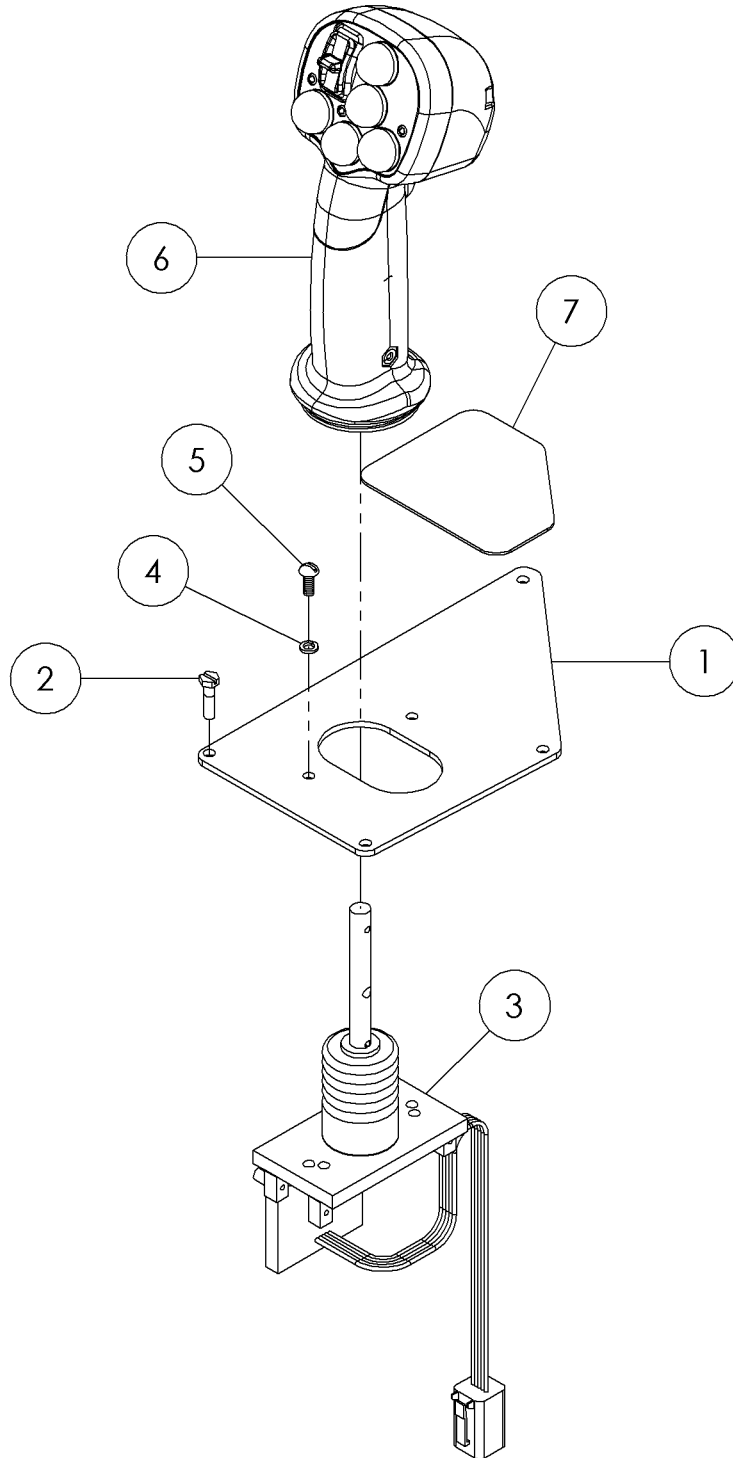

Illustration No. 296282532

## Left Joystick Panel Fig 9-3

REF. NO.	*	PART NO.	DESCRIPTION	QTY.	REMARKS
1		296282506	PLATE - JOYSTICK MOUNT	1	
2		510357010	SCREW-MCH-10-24X.75-GR2-YZ-HWH-SLOTTED	4	
3		296282533	JOYSTICK - SPRING CENTERED	1	
4		480001	WASHER-3/16 S/T LOCK	2	
5		1802004	BOLT-3/16"NF X 1/2" STOVE	2	
6		296273907	HANDLE GRIP ASSEMBLY - LEFT JOYSTICK	1	Breakdown Fig. 4-10z01
7		700IC857	DECAL-LEFT JOYSTICK CONTROL	1	

Upper RH Panel-Domestic Fig 9-4

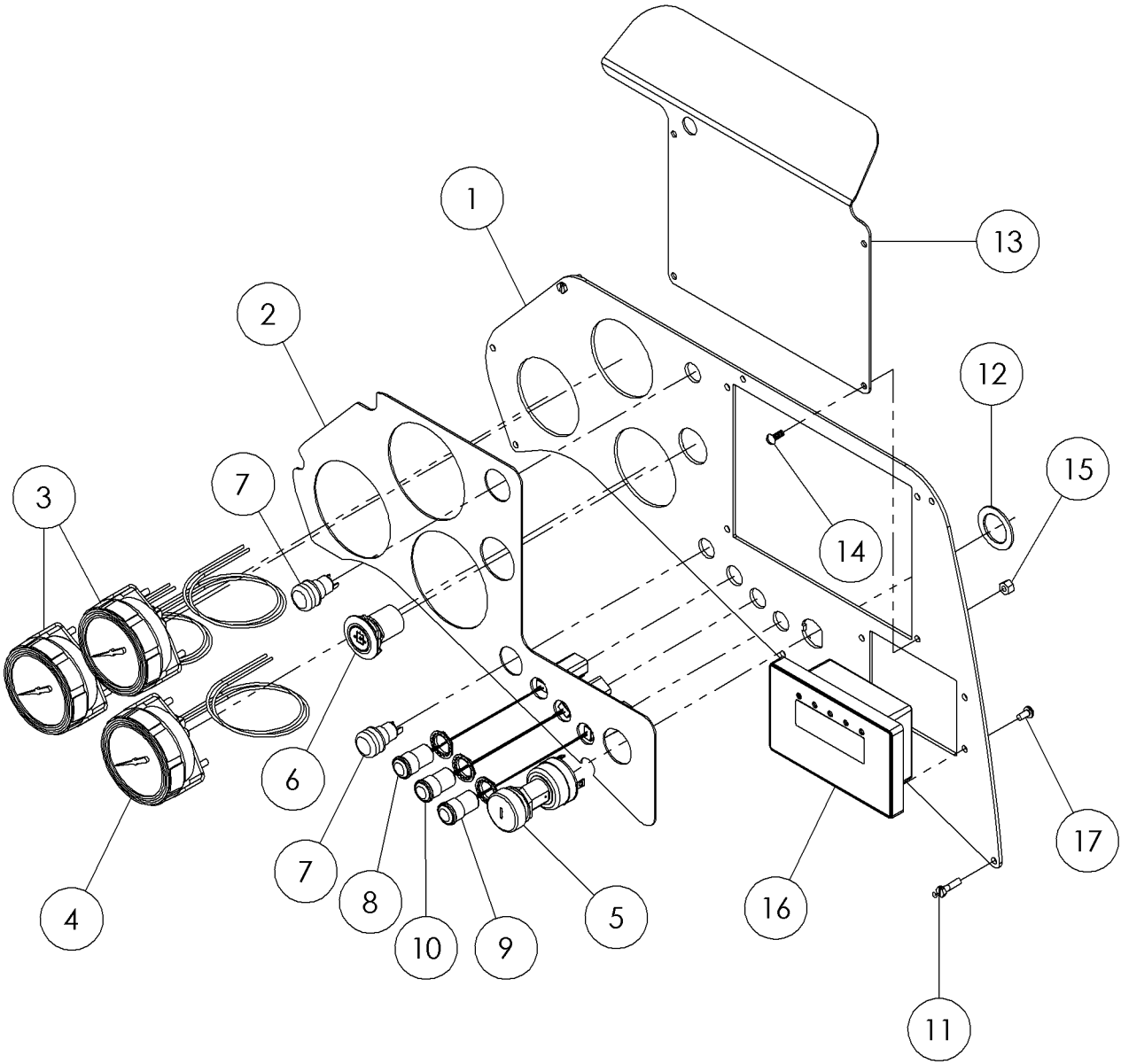

Illustration No. 296279940



## Upper RH Panel-Domestic Fig 9-4

REF. NO.	*	PART NO.	DESCRIPTION	QTY.	REMARKS
1		296286496	PANEL - DCI/ACS DISPLAY	1	
2		700IC699	DECAL - CONTROL RH UPPER D36X50II	1	
3		289651001	GAUGE - 7500 PSI - SPAN - JIC - LIGHT	2	
4		289650001	GAUGE - 2000 PSI - SPAN - JIC - LIGHT	1	
5		285597001	SWITCH - IGNITION	1	Includes With Key
		285597002	KEYS - IGNITION SWITCH (MATCHED PAIR)	A/R	
6		277699001	SWITCH - PUSH BUTTON HYDRAULIC ENABLE	1	Hydraulic Enable
7		260766001	SWITCH-MOM BUTTON NO	2	Alarm Off
8		296275581	LIGHT - REMOTE LOCKOUT-GREEN	1	Run Mode Light
9		296275582	LIGHT - RED	1	Lockout Mode Light
10		296275583	LIGHT - AMBER	1	Processing Light
11		510357010	SCREW-MCH-10-24X.75-GR2-YZ-HWH-SLOTTED	7	
12		483005	WASHER-1 1/2X1X14 GA M.B. ZINC	1	
13		296286479	PLATE - COVER/DCI MOUNT	1	
14		533004	BOLT-10-24X1/2 RND.HD.SLTMACH	4	
15		284471001	NUT - 10-24	4	
16		296287271	ASM - LED MID SIZE HDD	1	
17		229830001	SCREW-TFTAP-M5X10-YZ-D7500	4	

Upper RH Panel-International Fig 9-5

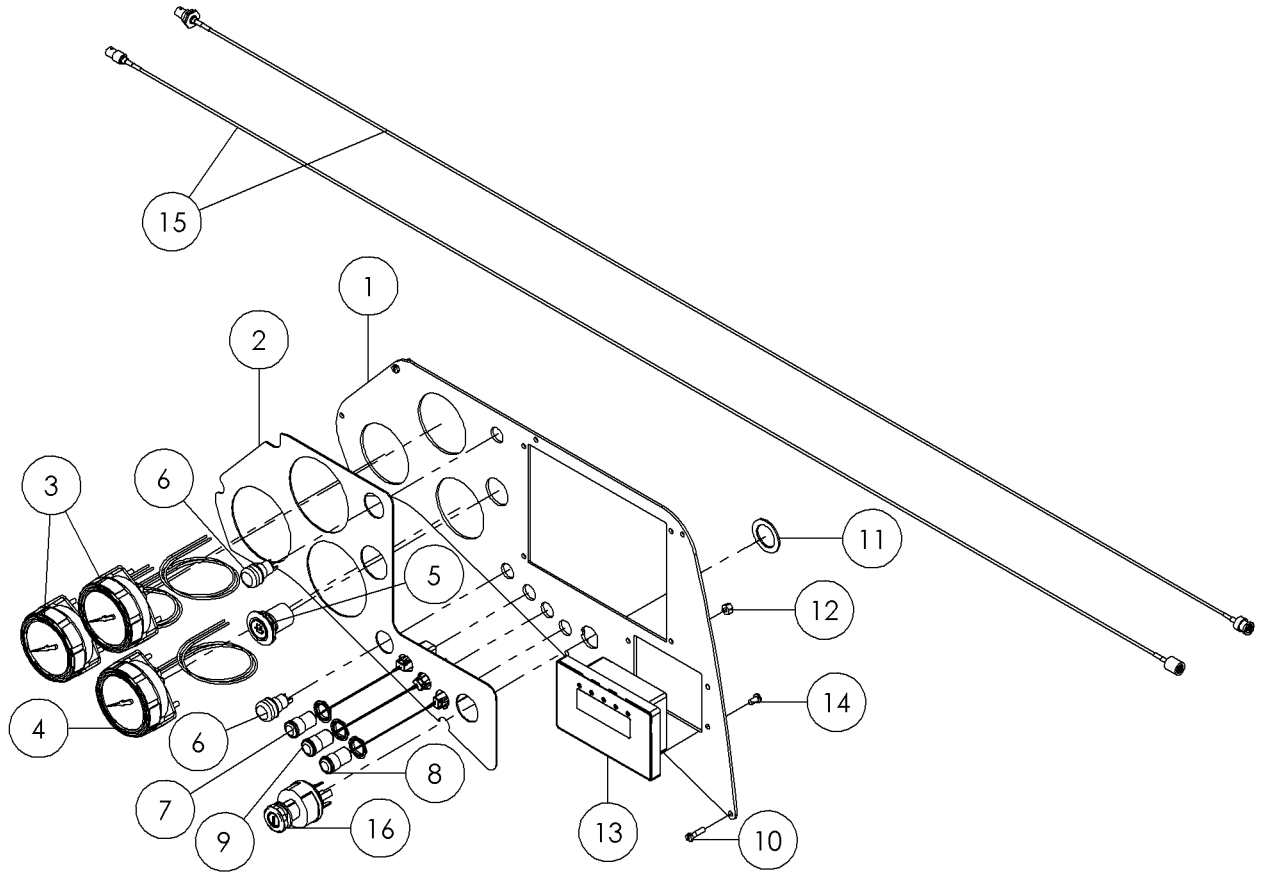

Illustration No. 296281943

## Upper RH Panel-International Fig 9-5

REF. NO.	*	PART NO.	DESCRIPTION	QTY.	REMARKS
1		296286496	PANEL - DCI/ACS DISPLAY	1	
2		700ic699	DECAL - CONTROL UPPER RH	1	
3		289651001	GAUGE - 7500 PSI - SPAN - JIC - LIGHT	2	
4		289650001	GUAGE SPAN - 200PSI	1	
5		277699001	SW - PUSH BUTTON HYD. ENABLE	1	Hydraulic Enable
6		260766001	SWITCH - MOM BUTTON NO	2	Alarm Off
7		296275581	LIGHT-REMOTE LOCKOUT - GREEN	1	Run Mode Light
8		296275582	LIGHT-REMOTE LOCKOUT- RED	1	Lockout Mode Light
9		296275583	LIGHT-REMOTE LOCKOUT-AMBER	1	Processing Light
10		510357010	SCREW-MCH-10-24X.75-GR2-YZ-HWH-SLTD	7	
11		483005	WASHER-MCHBSHG-1.00-1.03X1.50-14G-CZ	1	
12		284471001	NUT-TLHEX-#10-24-A-CZ	4	
13		296287271	ASM-LED MID SIZE HDD	1	
14		229830001	SCREW-TFTAP-M5-.80X10-10.9-YZ-D7500-PPH	4	
15		296281925	ASSY- CABLE MSD ANTENNA	1	
16		285597001	SWITCH 0 IGNITION	1	Including Key
		285597002	KEYS - IGNITION SWITCH (MATCHED PAIR)	A/R	

Lower RH Panel Fig 9-6

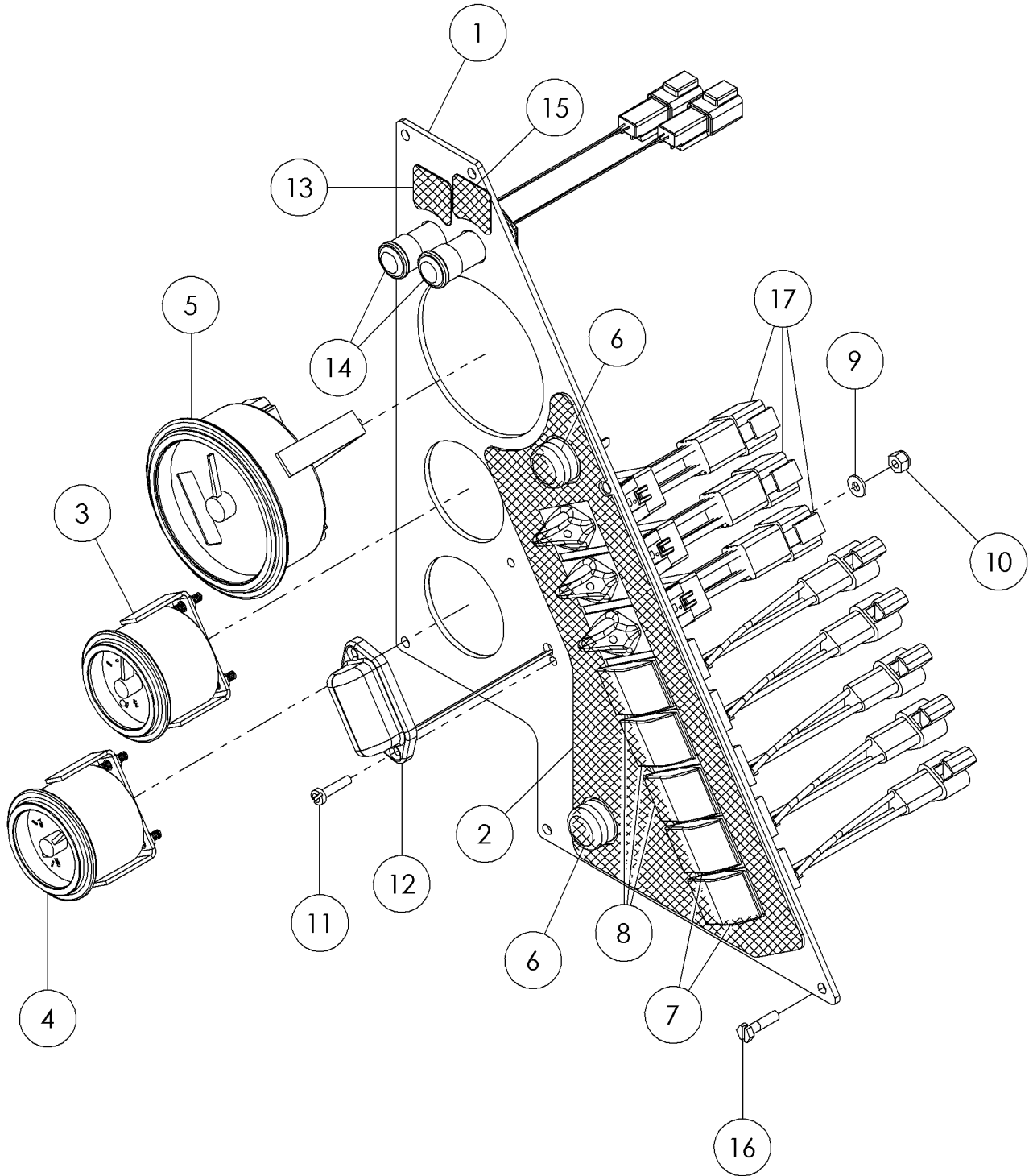

Illustration No. 296282528

## Lower RH Panel Fig 9-6

REF. NO.	*	PART NO.	DESCRIPTION	QTY.	REMARKS
1		296269646	PLATE - GAUGE PANEL - LOWER RIGHT	1	
2		700ID557	DECAL - CONTROL, RIGHT HAND LOWER	1	
3		296274330	GAUGE - FUEL	1	
4		296274329	GAUGE-TEMP DATCON 12V W/ DEUTSCH CONNECTR	1	
5		163627173	TACHOMETER CANBUS	1	
6		260766001	SWITCH-MOM BUTTON NO	2	(Engine Reset)(Display Scroll)
7		257541001	SWITCH-SPDT 3 POSITION MOM	2	(Left-Stakedown Cylinder)(Right-Stakedown Motor)
8		257205001	SWITCH-SP 2 POSITION	3	(Left-2-Speed Thrust/Pullback)(Middle Light)(Power Stakedown)
9		224769001	WASHER-#8 FLAT	2	
10		69759001	LOCK NUT-#8-32 NYLON INSERT PL	2	
11		10530006	SCREW-#8-32X3/4 SLOT RD.HD.	2	
12		296256067	LIGHT - CONSOLE, M434	1	
13		700IC414	DECAL- ENGINE WARNING	1	
14		296275582	LIGHT - RED	2	(Left-Engine Warning Light)(Right-Hydraulic Filter Warning Light)
15		700IC557	DECAL - HYD. FILTER WARNING LIGHT	1	
16		510357010	SCREW-MCH-10-24X.75-GR2-YZ-HWH-SLOTTED	6	
17		296286254	ROTARY SWITCH (ON) - OFF - (ON)	3	(Left-Rotation Trim)(Middle-Thrust/Pullback Trim)(Right-Drilling Fluid Trim)

Accessory Panel Fig 9-7

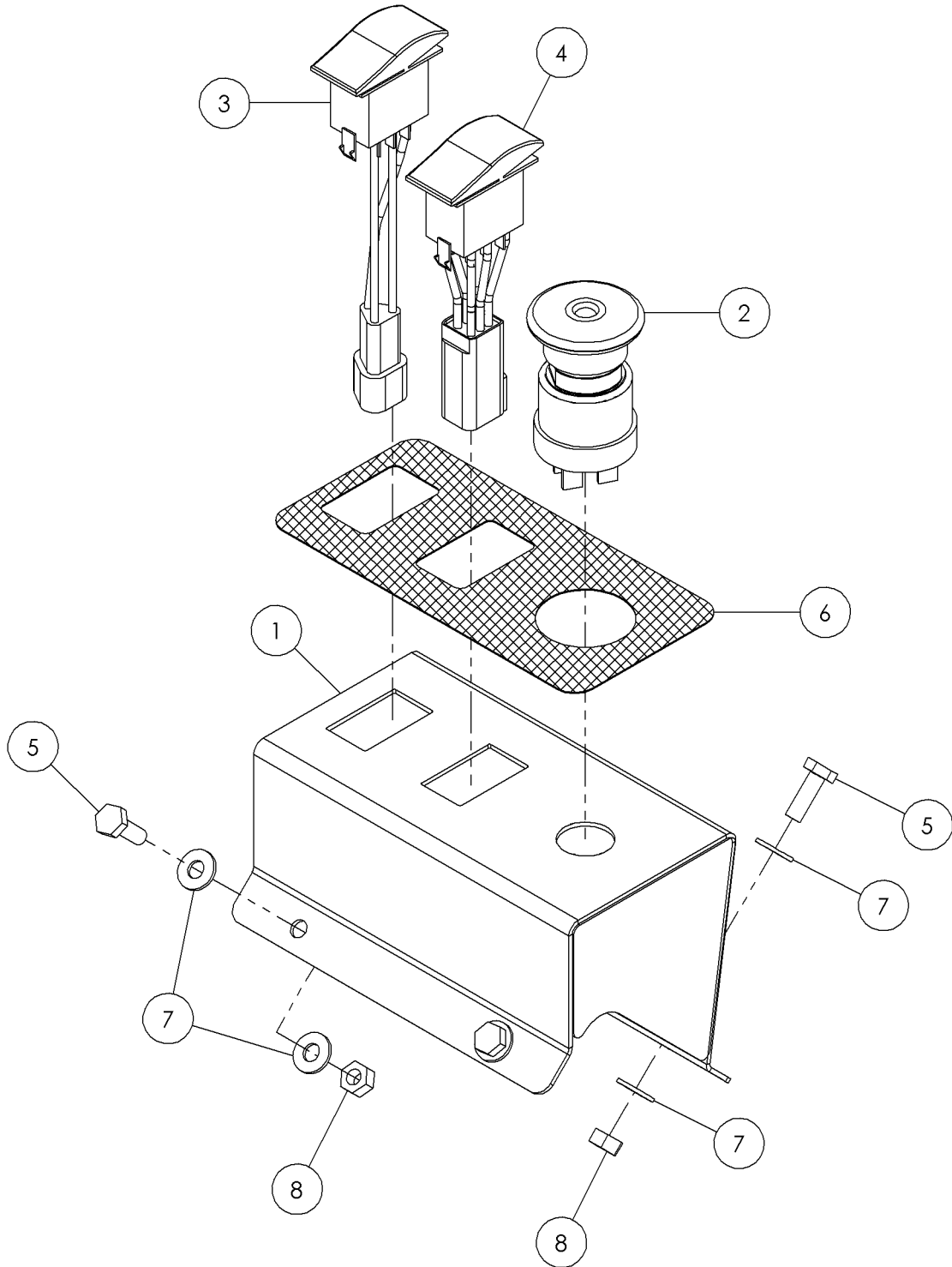

Illustration No. 296279942

## Accessory Panel Fig 9-7

REF. NO.	*	PART NO.	DESCRIPTION	QTY.	REMARKS
1		296280878	MOUNT-REAR SWITCHEST	1	
2		296259684	BUTTON - RED PUSH/PULL	1	Engine Shutoff
3		257541001	SWITCH-SPDT 3 POSITION MOM	1	Rear Stabilizer
4		296279988	SWITCH - ON# ON ON#	1	Throttle
5		235734001	BOLT-1/4-20X3/4 GR8 ZYC	4	
6		700ic665	DECAL - CONTROL REAR TRANSPORT	1	
7		235716001	WASHER-FLATSTRL-.25-.28 X .63 - .06 - CZ	8	
8		235732001	NUT - HEX - .25 - 20 - GR8 - YZ	4	

Right Joystick Panel Fig 9-8

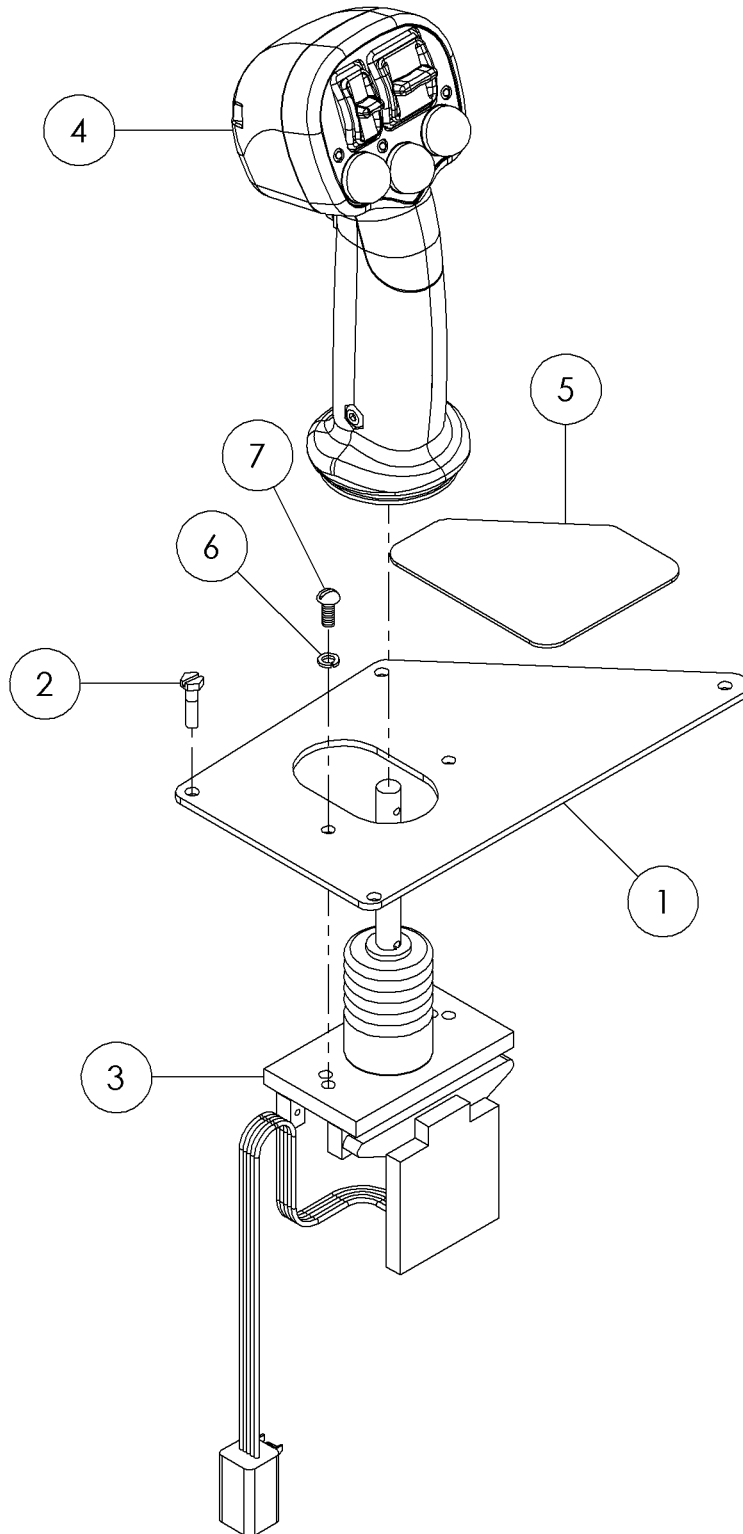

Illustration No. 296282531



## Right Joystick Panel Fig 9-8

REF. NO.	*	PART NO.	DESCRIPTION	QTY.	REMARKS
1		296282506	PLATE - JOYSTICK MOUNT	1	
2		510357010	SCREW-MCH-10-24X.75-GR2-YZ-HWH-SLOTTED	4	
3		296282533	JOYSTICK - SPRING CENTERED	1	
4		296273908	HANDLE GRIP ASSEMBLY - RIGHT JOYSTICK	1	Breakdown Fig. 4-11z01
5		700IC352	DECAL - CONTROL RIGHT HAND JOYSTICK	1	
6		480001	WASHER-3/16 S/T LOCK	2	
7		1802004	SCREW-MCH-10-32X.50-GR2-CZ-ROUND-SLTD	2	

Battery Fig 9-9

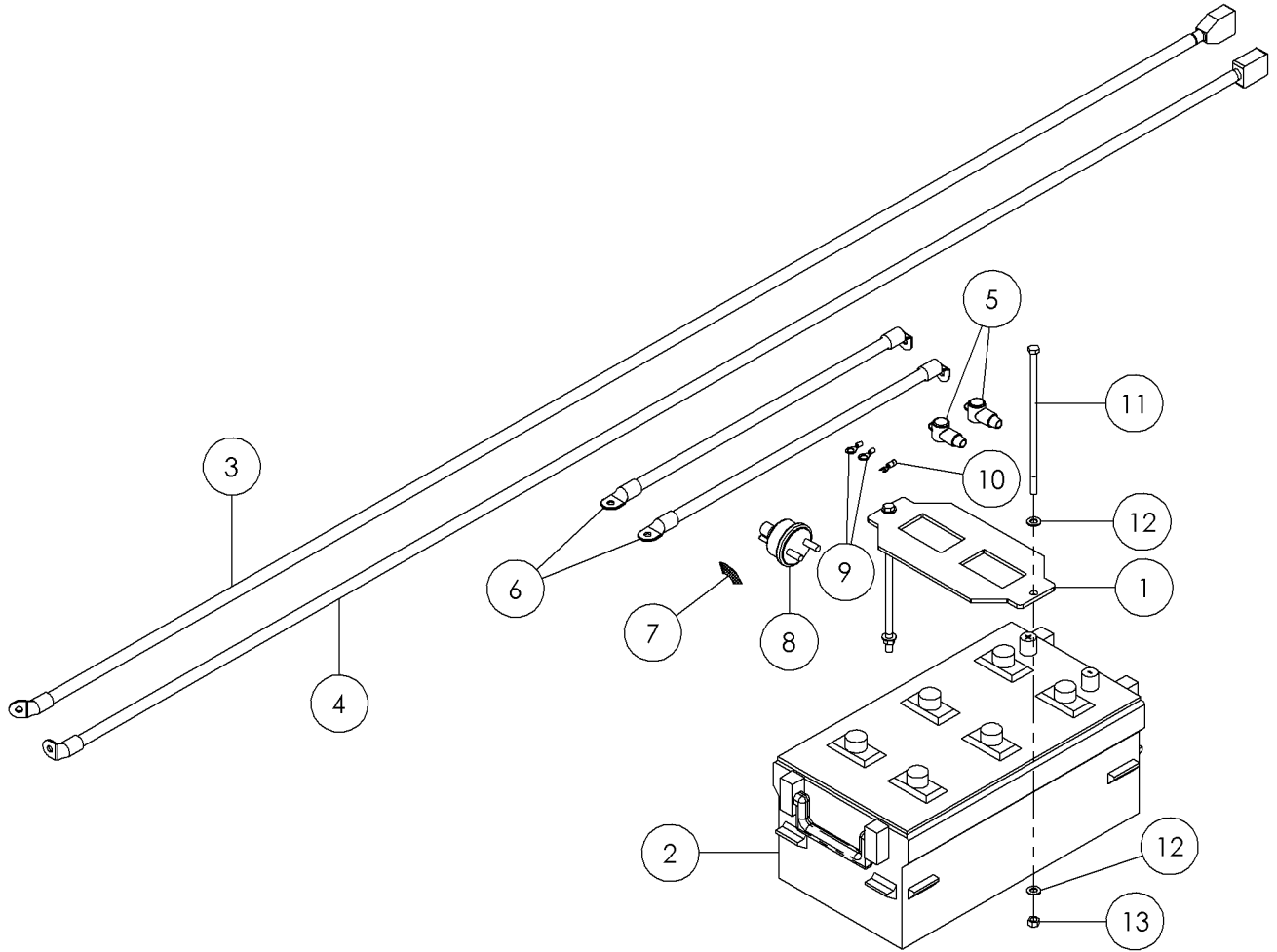

Illustration No. 296287813

## Battery Fig 9-9

REF. NO.	*	PART NO.	DESCRIPTION	QTY.	REMARKS
1		296287812	PLATE - BATTERY HOLD DOWN	1	
2			BATTERY - 12V 1400 CCA	1	Not Sold Separately
3		296286548	CABLE - BATTERY 4/0 97" RED P-E	1	
4		296286547	CABLE - BATTERY 4/0 97" BLACK P-E	1	
5		296269641	BOOT - BATTERY ALTERNATOR COVER	2	
6		296279963	CABLE - BATTERY 3/0-24" BLACK E-E-	2	
7		700IC950	DECAL - CONTROL, BATTERY DISCONNECT	1	Domestic/International
8		904365001	DISCONNECT SWITCH	1	
9		296300518	TERMINAL, 3/8" RING 8 GA	2	
10		296300519	TERMINAL, #10 SNAP SPADE 12-10 GA	1	
11		296264100	SCREW - HCS - .38 - 16 X 10 GR8 0YZ	2	
12		235713001	WASHER-FLATSTRL-.38-.41X.81-.06-YA-A325	4	
13		235725001	NUT - HEX - .38 - 16 - GR8 - YZ	2	

Engine Electrical Panel Fig 9-10

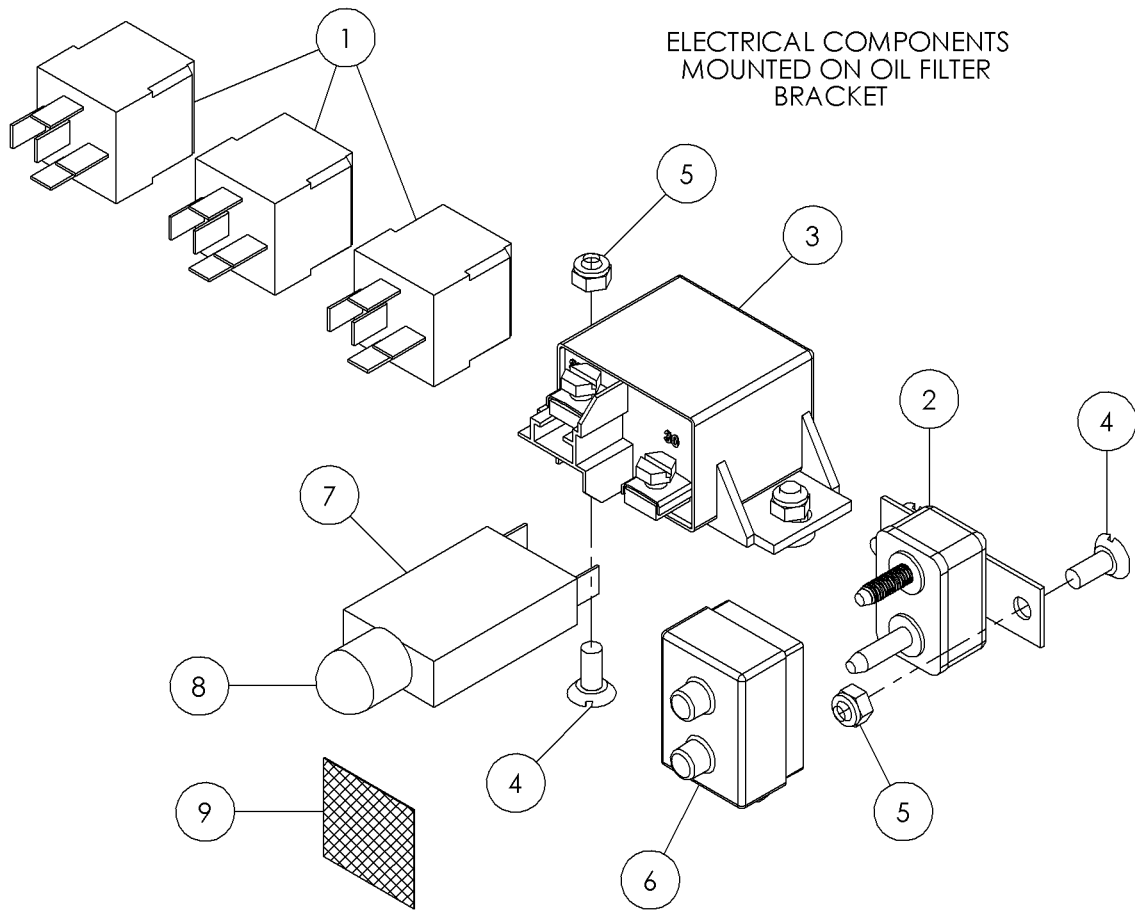

Illustration No. 296279948

## Engine Electrical Panel Fig 9-10

REF. NO.	*	PART NO.	DESCRIPTION	QTY.	REMARKS
1		296286772	CONTROL RELAY - 12V,40.30 AMP, SPDT	3	
2		86582001	BREAKER-40A TYPE 1 W/METALCASE	1	
3		86217001	RELAY-BOSCH SPST 75 AMP SEALED	1	
4		79525001	SCREW-#10-24X1/2 FLHD MACHINE	4	
5		99042001	NUT - NYLOCK - 10 - 24 - GR2 - CZ	4	
6		296269640	BOOT - RED COVER CIRCUIT BREAKER	1	
7		72081001	BREAKER 2-5700-514 DD 15 AMP	1	
8		89597001	COVER-BREAKER SWITCH	1	
9		700IC997	DECAL - BRAKER RESET ROTATION LIMITER	1	

Work Light Fig 9-11

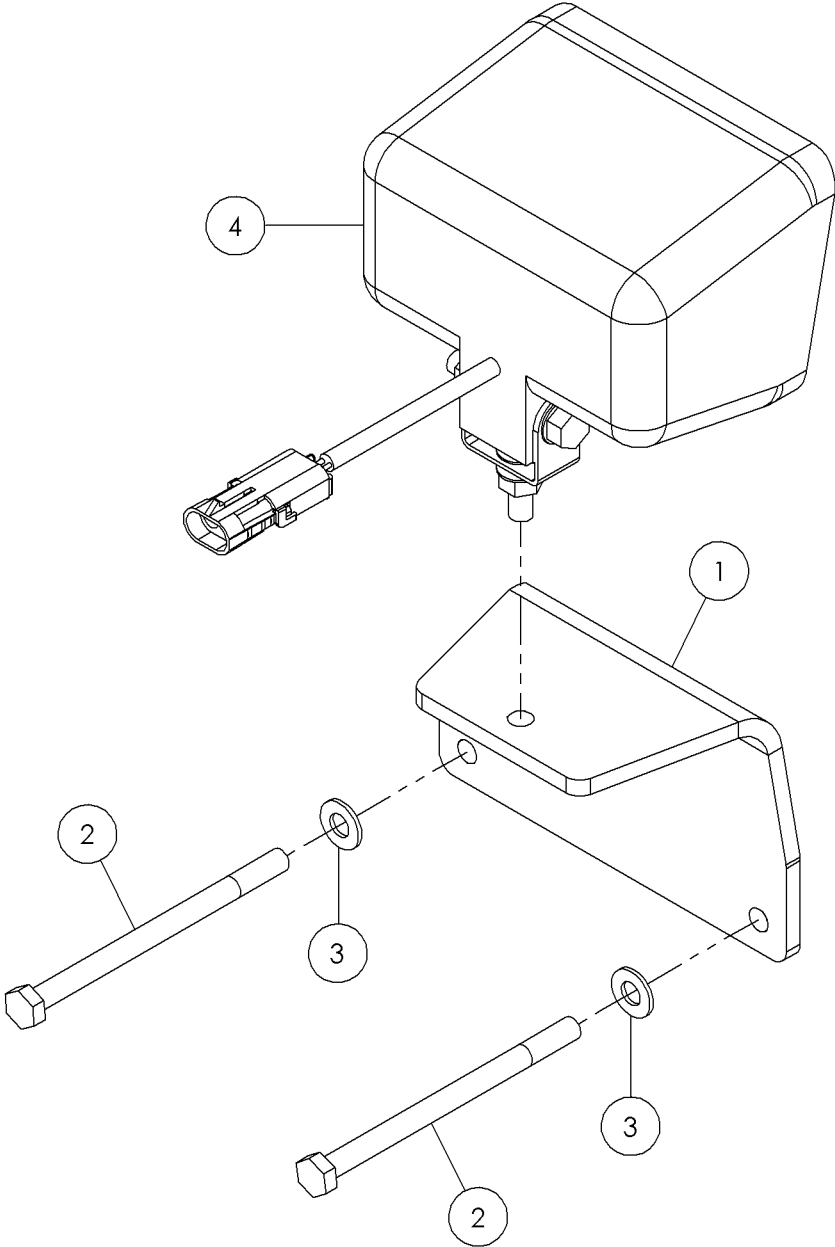

Illustration No. 296279949

## Work Light Fig 9-11

REF. NO.	*	PART NO.	DESCRIPTION	QTY.	REMARKS
1		279148001	PLATE - MOUNT	1	
2		250523001	BOLT-5/16-18 X 4 1/2 GR8 HEX Y	2	
3		235714001	WASHER-FLATSTRL-.31-.34X.69-.06-YZ-A325	2	
4		245006001	ASSEMBLY-3X5 FLOOD LIGHT	1	

Slowdown & Anticrash-10' Fig 9-12

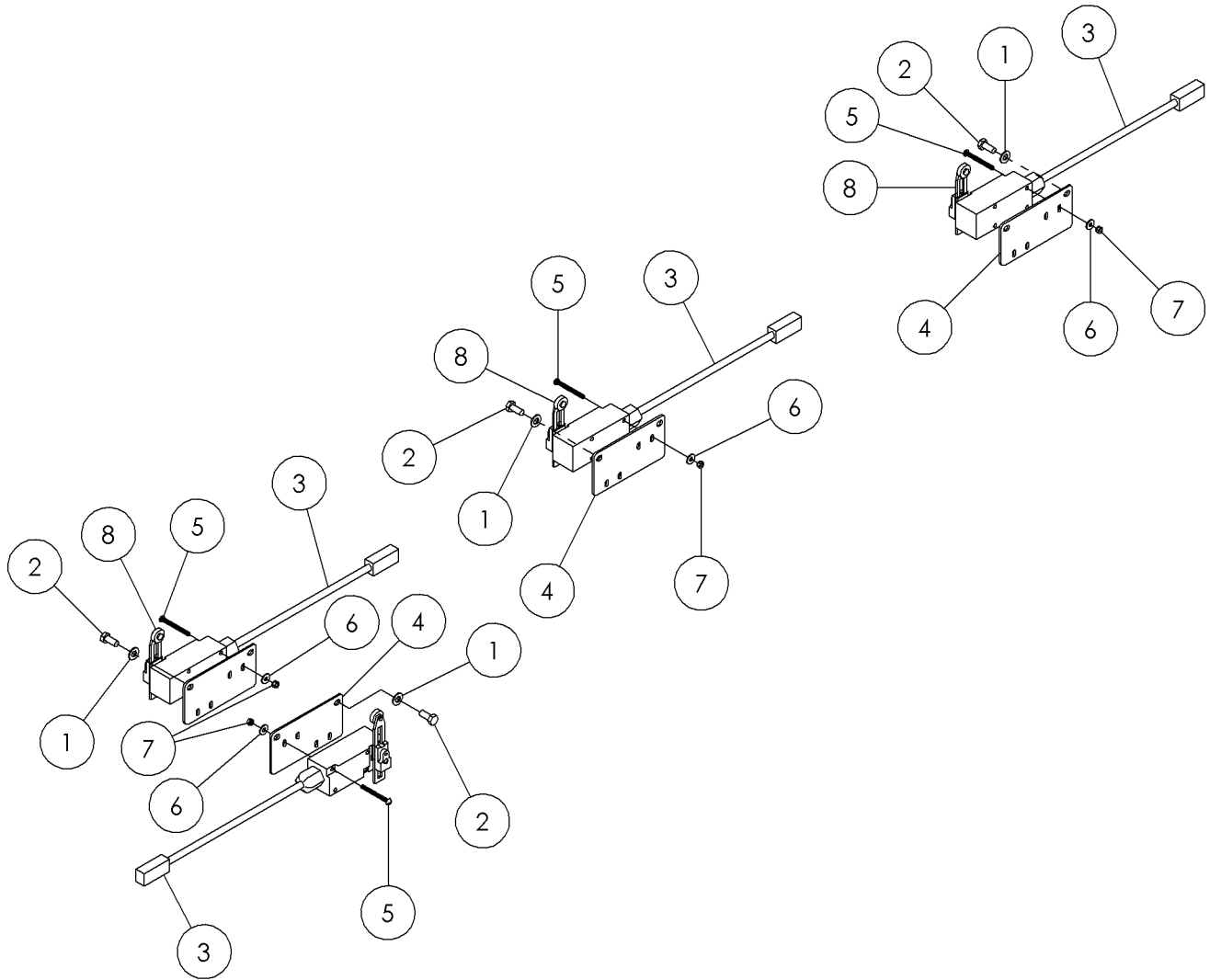

Illustration No. 296289022



## Slowdown &amp; Anticrash-10' Fig 9-12

REF. NO.	*	PART NO.	DESCRIPTION	QTY.	REMARKS
1		235714001	WASHER-FLATSTRL-.31-.34X.69-.06-YZ-A325	8	
2		235742001	BOLT-5/16-18X3/4 GR8 ZYC	8	
3		279362001	LIMIT SWITCH ASSY - MICRO	4	
4		296289026	PLATE - SWITCH MOUNT	4	
5		533020	SCREW-10-24X2 RND.HD.SLT.MACH.	8	
6		485001	WASHER-FLATSTD-.19-.22X.56-.05 - CZ	8	
7		99042001	NUT - NYLOCK - 10 - 24 - GR2 - CZ	8	
8		296289023	LEVER - LIMIT SWITCH ADJUSTABLE	4	

Slowdown & Anticrash-15' Fig 9-13

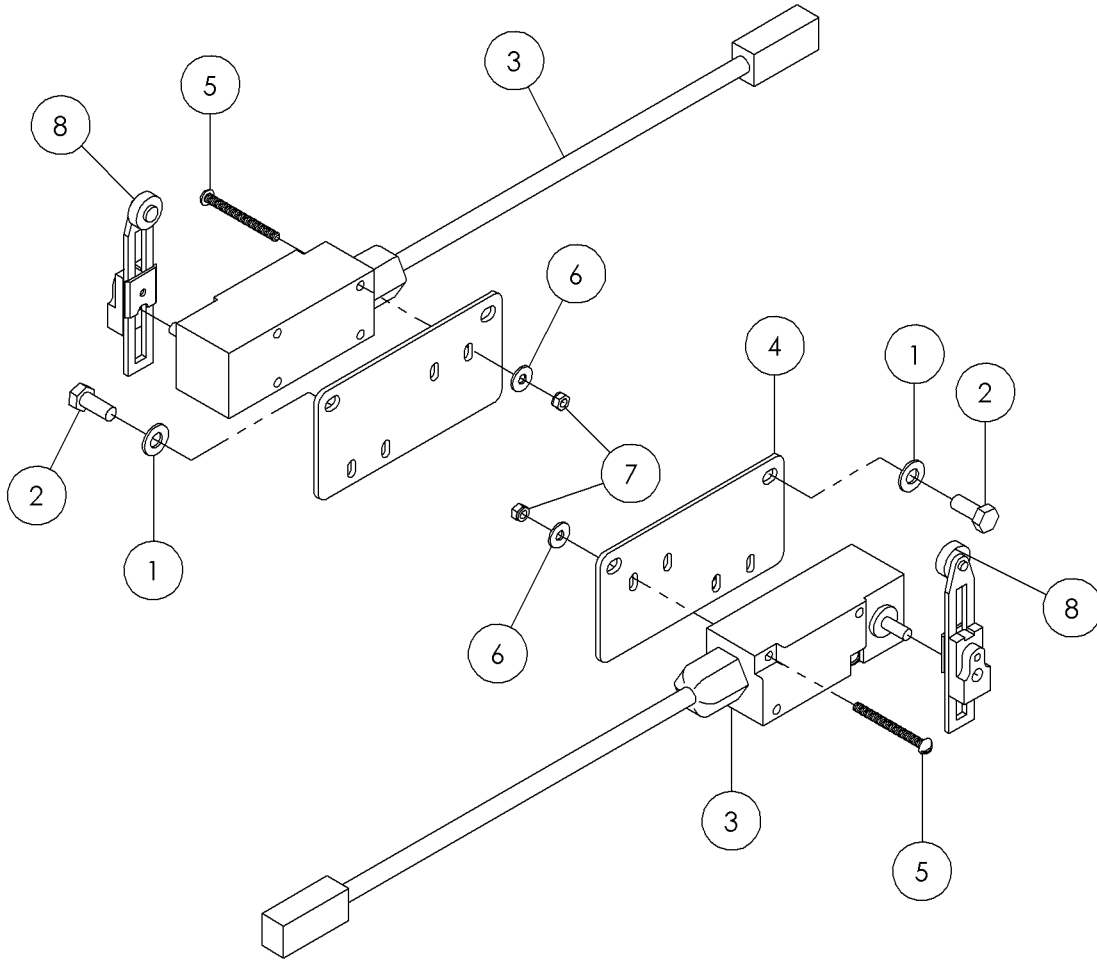

Illustration No. 296289039

## Slowdown &amp; Anticrash-15' Fig 9-13

REF. NO.	*	PART NO.	DESCRIPTION	QTY.	REMARKS
1		235714001	WASHER-FLATSTRL-.31-.34X.69-.06-YZ-A325	4	
2		235742001	BOLT-5/16-18X3/4 GR8 ZYC	4	
3		279362001	LIMIT SWITCH ASSY - MICRO	4	
4		296289026	PLATE - SWITCH MOUNT	2	
5		533020	SCREW-10-24X2 RND.HD.SLT.MACH.	8	
6		485001	WASHER-FLATSTD-.19-.22 X .56 - .05 - CZ	8	
7		99042001	NUT - NYLOCK - 10 - 24 - GR2 - CZ	8	
8		296289023	LEVER - LIMIT SWITCH ADJUSTABLE	4	

Remote Lockout-International Fig 9-14

Illustration No. 296280993

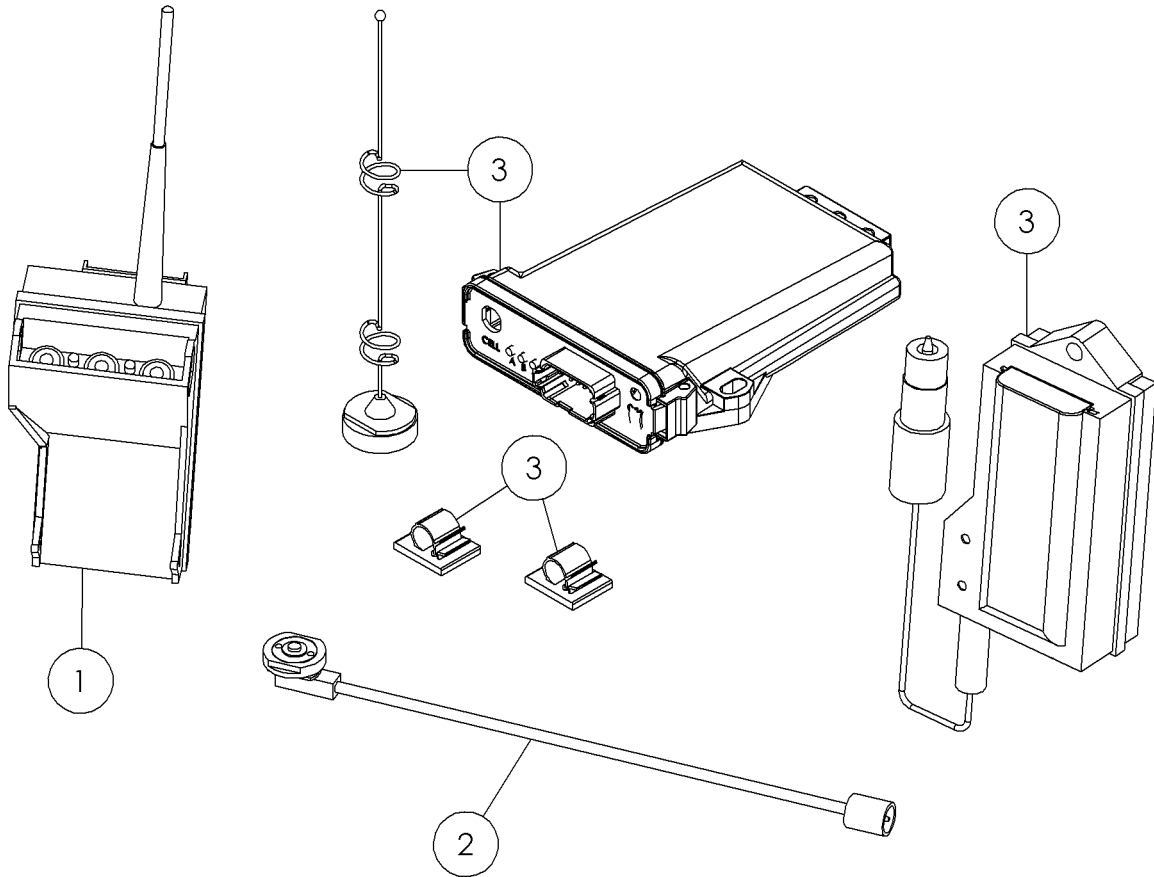

## Remote Lockout-International Fig 9-14

REF. NO.	*	PART NO.	DESCRIPTION	QTY.	REMARKS
1		296272513	R324LK, REMOTE LOCKOUT INT	1	
2		296272607	MOUNT-ANTENNA MOTOROLA TYPE RG-58-4'	1	
3		296280375	KIT-REMOTE LOCKOUT-INTERNATIONAL	1	Breakdown Fig. 9-14z01

Components-Remote Lockout-International Fig 9-14z01

Illustration No. 296280375

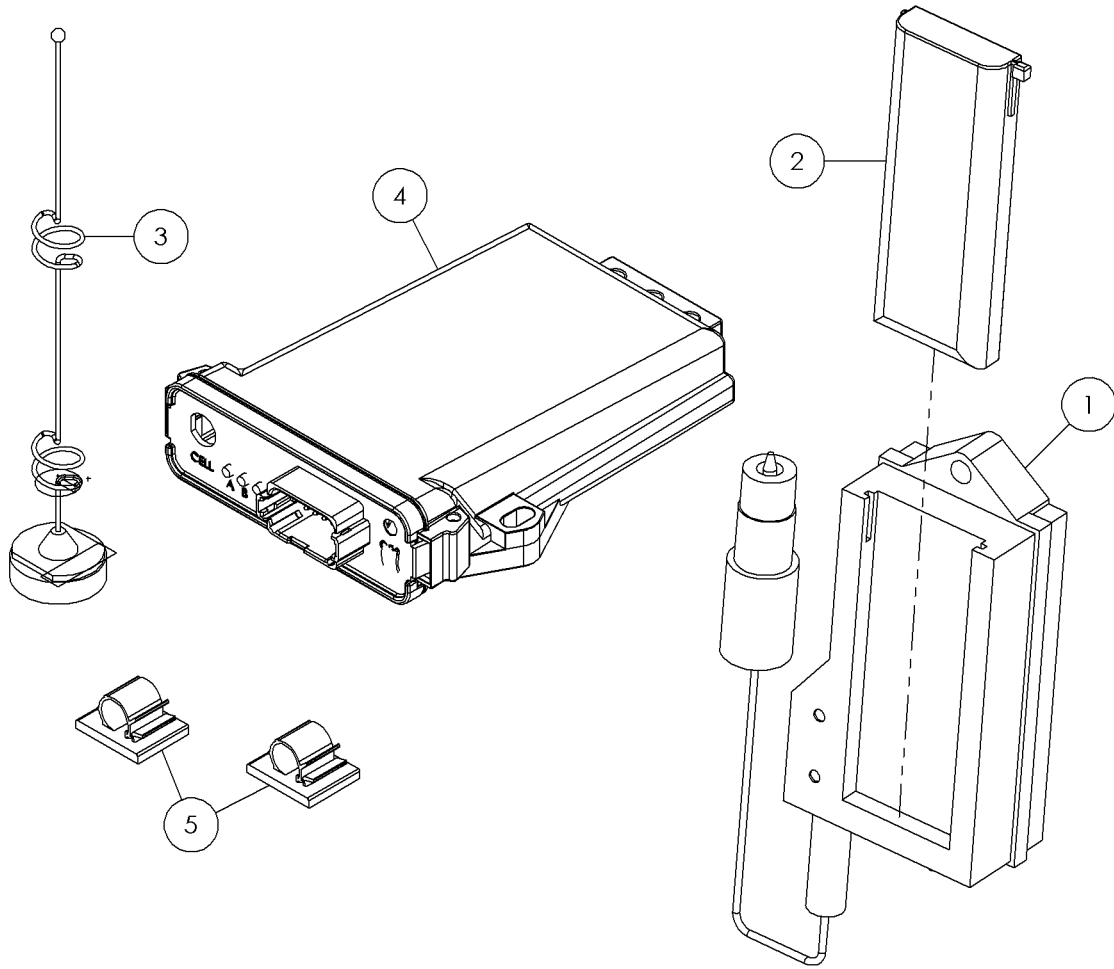

## Components-Remote Lockout-International Fig 9-14z01

REF. NO.	*	PART NO.	DESCRIPTION	QTY.	REMARKS
1		296272392	CHARGER, 12-VOLT NBB	1	
2		296272400	BATTERY - 1000MA NBB	1	
3		296272382	ANTENNA - 2400MHZ 1/4 WAVE	1	
4		296272509	B324LK1, HYDRAULIC STANDALONE INT	1	
5		279318001	CLAMP - ADHESIVE MOUNT	2	
		296280375	KIT-REMOTE LOCKOUT-INTERNATIONAL		Includes All Items In Figure

Remote Lockout-Domestic Fig 9-15

Illustration No. 296280992

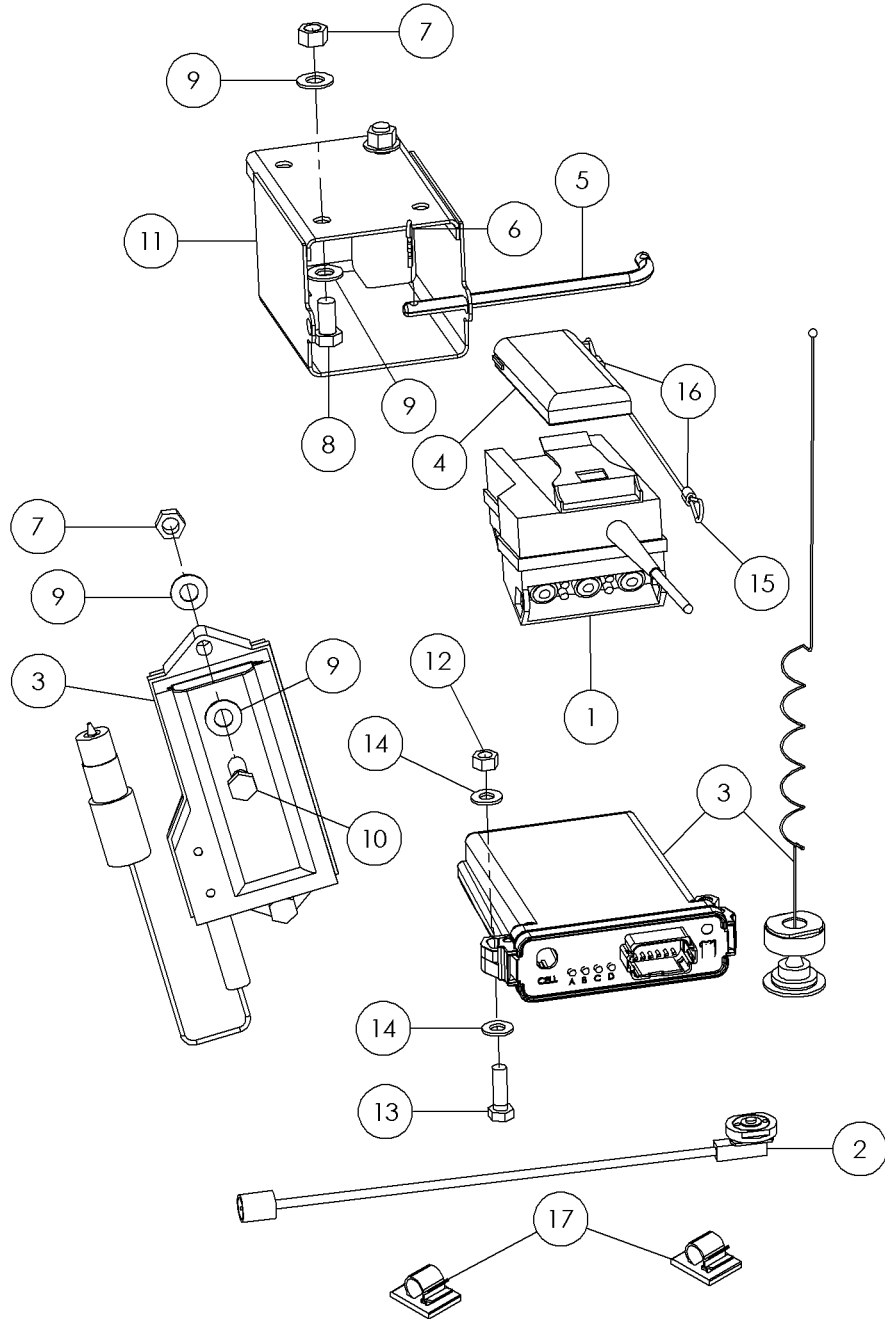



## Remote Lockout-Domestic Fig 9-15

REF. NO.	*	PART NO.	DESCRIPTION	QTY.	REMARKS
1		296272303	ASM - R309LK FOR HDD	1	
2		296272607	MOUNT-ANTENNA MOTOROLA TYPE RG-58-4'	1	
3		296280372	KIT-REMOTE LOCKOUT-DOMESTIC	1	
4		296272400	BATTERY - 1000MA NBB	1	
5		296274192	PIN - REMOTE BOX	1	
6		1794007	HAIR PIN COTTER - .080 WIRE	1	
7		235725001	NUT - HEX - .38 - 16 - GR8 - YZ	4	
8		235726001	BOLT-3/8-16X3/4 GR8 HEX ZNCPLT	2	
9		235713001	WASHER-FLATSTRL-.38-.41X.81-.06-YA- A325	8	
10		235723001	SCREW - HCS - .38 - 16 X 1.50 - GR8 - YZ	2	
11		296289028	WELD - REMOTE BOX	1	
12		235741001	NUT - HEX - .31 - 18 - GR8 - YZ	2	
13		238209001	BOLT-5/16-18X1 GR8 HEX ZINC YC	2	
14		235714001	WASHER-FLATSTRL-.31-.34X.69-.06-YZ- A325	4	
15		142954001	CABLE-.068DIA.NYLON CT.-36.00	1	
16		142423001	CRIMP-CABLE (FOR.068DIA.CABLE)	2	
17		279318001	CLAMP - ADHESIVE MOUNT	2	

Controller W/Hardware Fig 9-16

NOTE: MUST BE PROGRAMMED BEFORE  
INSTALLATION/USE. REFER TO COMPASS  
FOR PROGRAMMING INSTRUCTIONS.

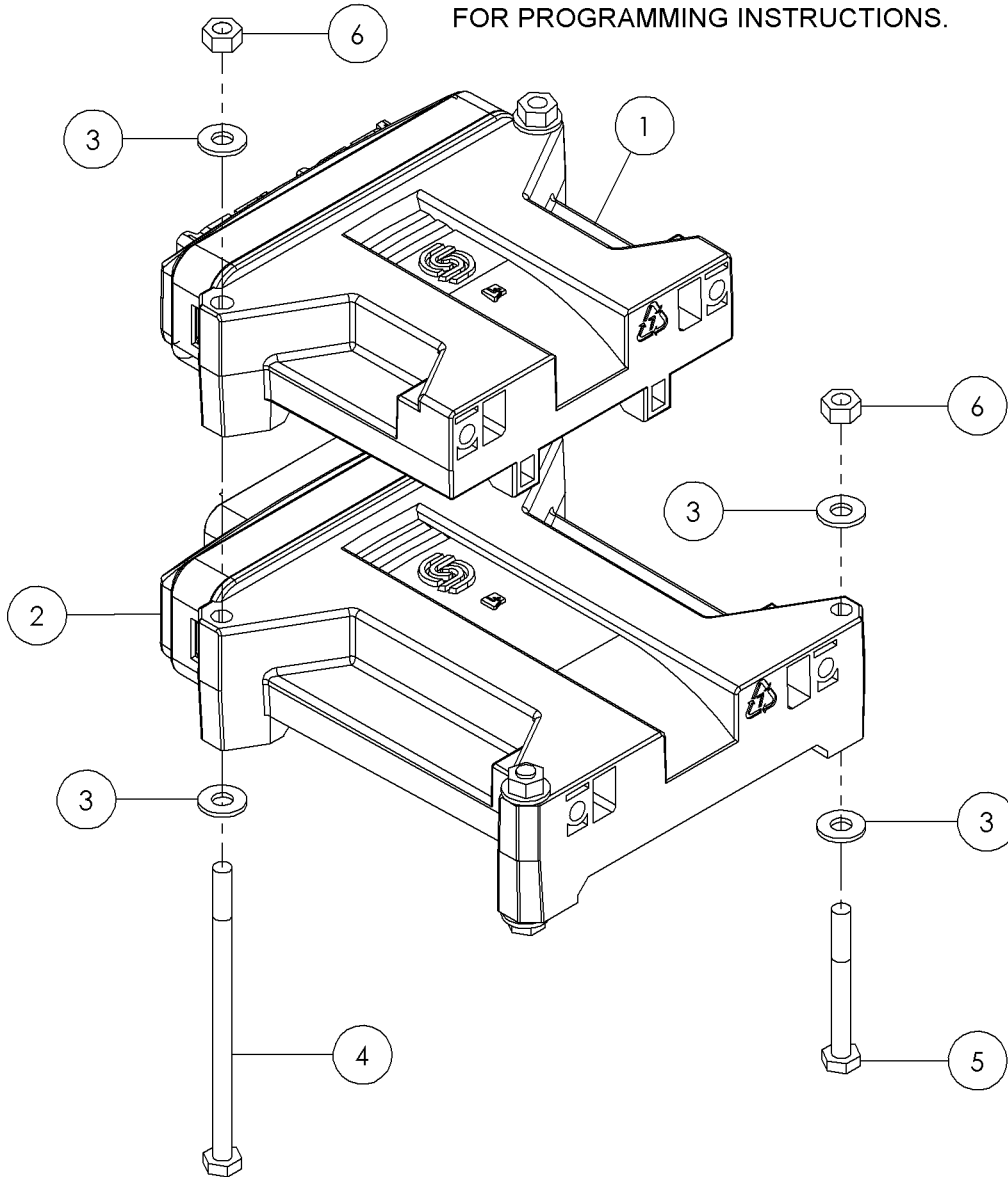

## Controller W/Hardware Fig 9-16

REF. NO.	*	PART NO.	DESCRIPTION	QTY.	REMARKS
1		296276084	CONTROLLER - PLUS 1	1	
2		296273863	CONTROLLER-M050-100 (UNPROGRAMMED)	1	
3		252251001	WASHER-1/4 SAE FLAT ZP	8	
4		296258562	SCREW - HCS - .25 - 20 X 4.50 - GR8 - YZ	2	
5		250644001	BOLT-1/4-20 X2 1/4 GR 8 Y/ZINC	2	
6		235732001	NUT - HEX - .25 - 20 - GR8 - YZ	4	

Rod Loader Switches Fig 9-17

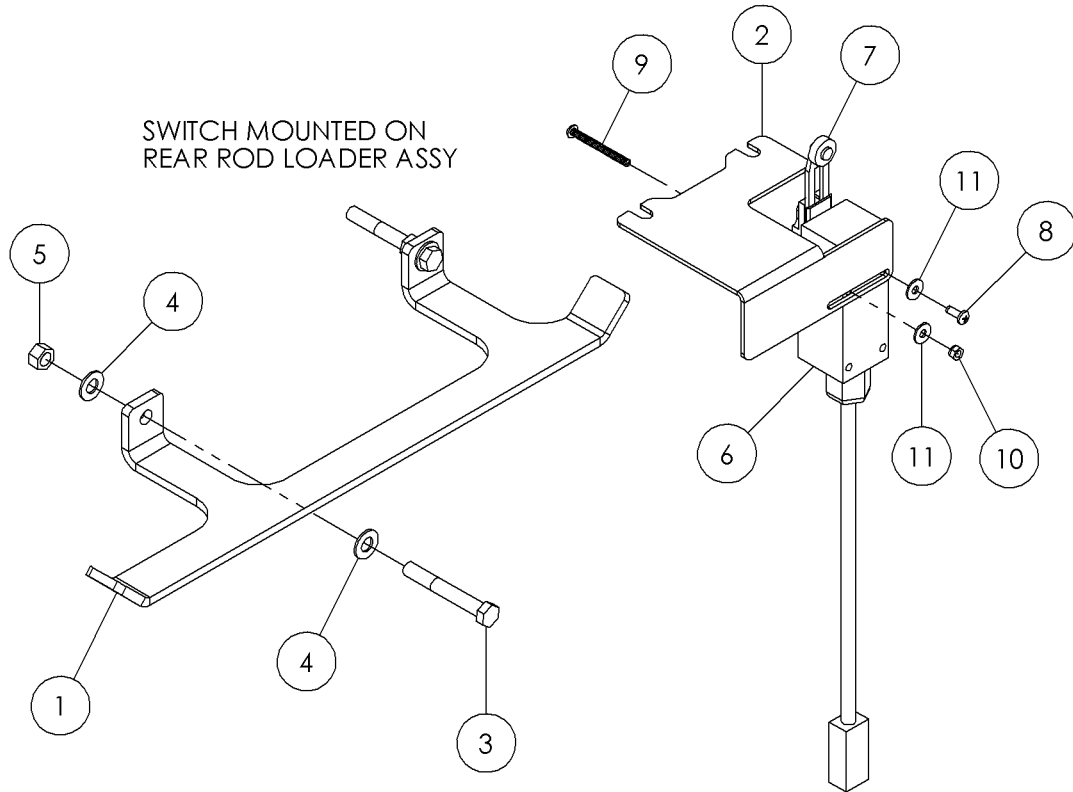

## Rod Loader Switches Fig 9-17

REF. NO.	*	PART NO.	DESCRIPTION	QTY.	REMARKS
1		296289020	PLATE - SWITCH MOUNT INDICATOR	1	
2		296289025	PLATE - SWITCH MOUNT	1	
3		250640001	BOLT-3/8-16 X2 3/4 GR 8 Y/ZINC	2	
4		235713001	WASHER-FLATSTRL-.38-.41X.81-.06-YA-A325	4	
5		250508001	NUT - 3/8-NC Gr8 TOP LOCK Y/ZINC	2	
6		279362001	LIMIT SWITCH ASSY - MICRO	1	
7		296289023	LEVER - LIMIT SWITCH ADJUSTABLE	1	
8		141364001	SCREW-10-32 X 1/2 CRPHM	1	
9		533020	SCREW-10-24X2 RND.HD.SLT.MACH.	1	
10		99042001	NUT - NYLOCK - 10 - 24 - GR2 - CZ	1	
11		485001	WASHER-FLATSTD-.19-.22X.56-.05 - CZ	2	

Mount W/PPU Fig 9-18

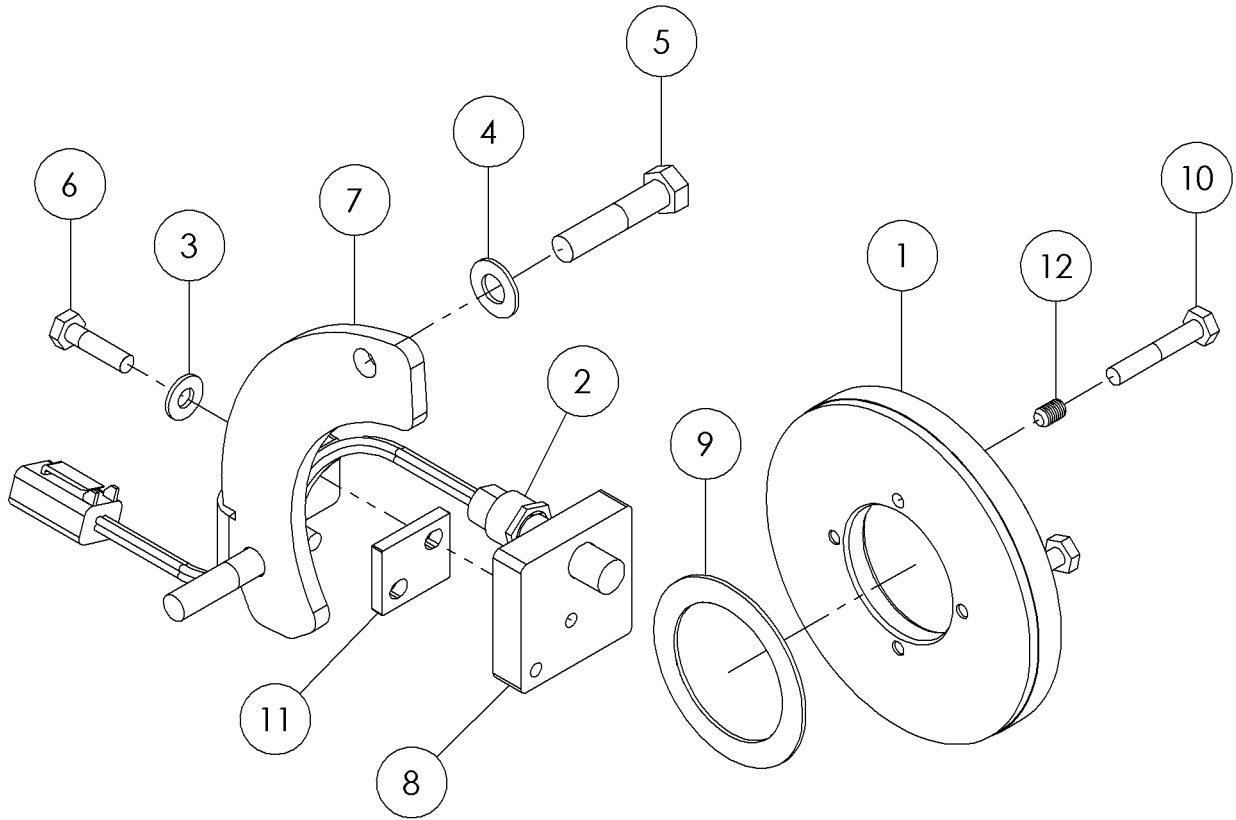
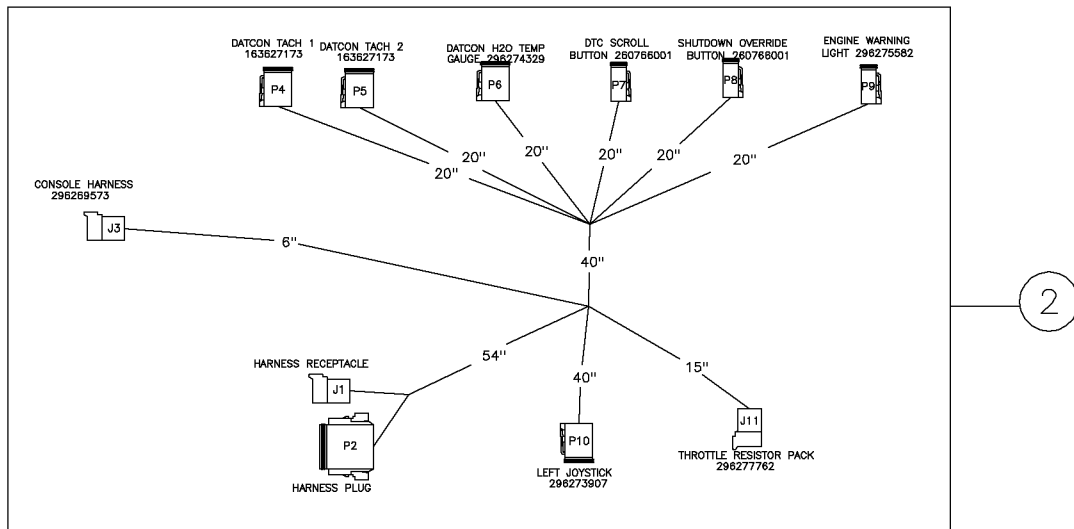
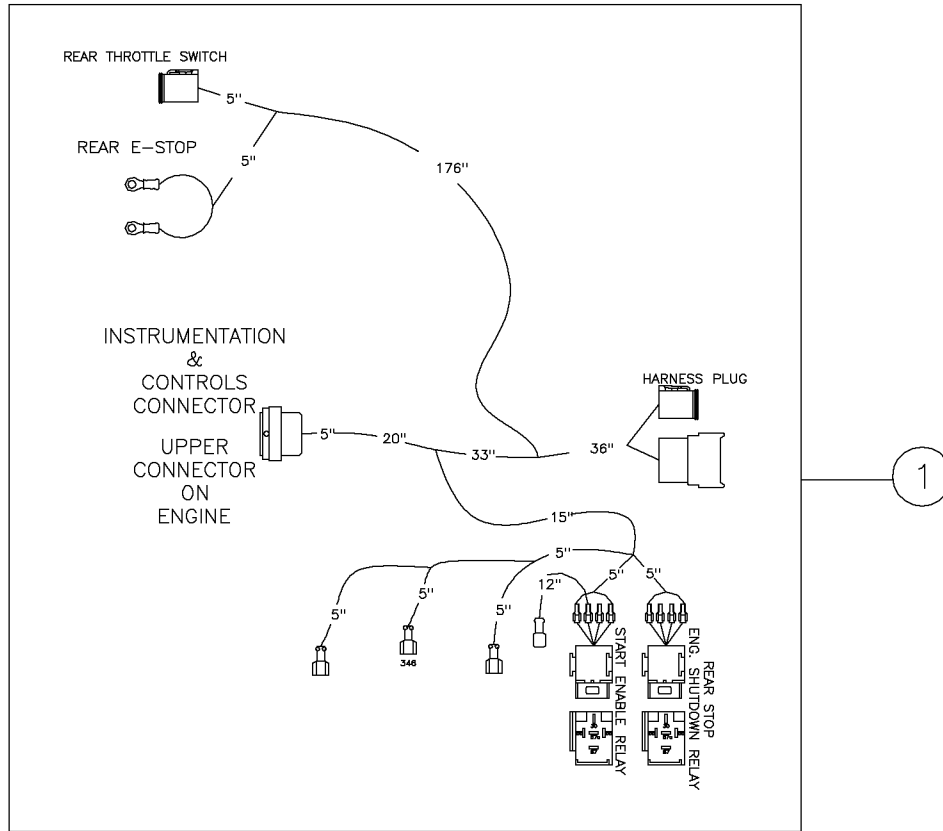

Illustration No. 296282510

## Mount W/PPU Fig 9-18

REF. NO.	*	PART NO.	DESCRIPTION	QTY.	REMARKS
1		296286252	ASSEMBLY - PULSE RING	1	
2		296281808	PULSE PICKUP SENSOR	1	
3		235716001	WASHER - FLATSTRL - .25 -.28 X .63 - .06 - CZ	2	
4		235713001	WASHER-FLATSTRL-.38-.41X.81-.06-YA-A325	2	
5		235720001	BOLT-3/8-16X1 3/4 6R8 ZINC PLT	2	
6		235735001	BOLT-1/4-20X1 GR8 HEX ZYC	2	
7		296265381	MOUNT - PULSE PICKUP 36X50II	1	
8		296265451	THD PLATE - 9/16-18	1	
9		296286253	WASHER - 1.96 X 2.68 X .093 (BUNA-N)	1	
10		238210001	BOLT - 1/4-20X1 1/2 GR8 HEX ZYC	2	
11		296282545	PLATE - SPACER PPU	1	
12		523001	SSS-1/4-20X3/8	4	

Harness-Deere 4045H HP Fig 9-19





## Harness-Deere 4045H HP Fig 9-19

REF. NO.	*	PART NO.	DESCRIPTION	QTY.	REMARKS
1		296287983	WIRE HARNESS-DEERE 4045 ENGINE 140 HP	1	Update Harness
2		296287987	WIRE HARNESS - CONSOLE ENGINE COMM.	1	

Harness-Rotation Gearbox Fig 9-20

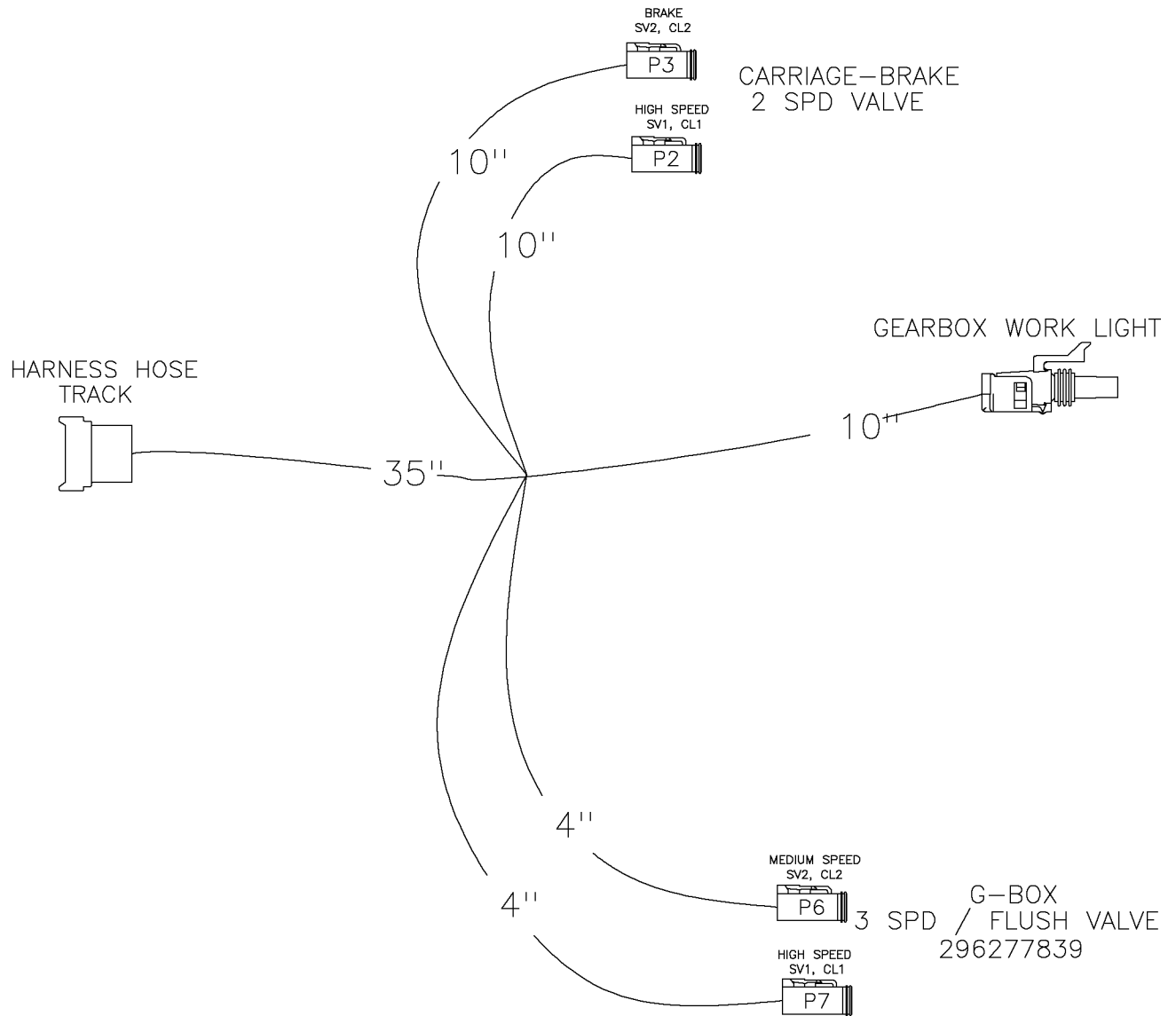

Harness-Rotation Gearbox Fig 9-20

REF. NO.	*	PART NO.	DESCRIPTION	QTY.	REMARKS
1		296269650	WIRE HARNESS - ROTATION GEAR BOX	1	

Harness-Engine Bay Fig 9-21

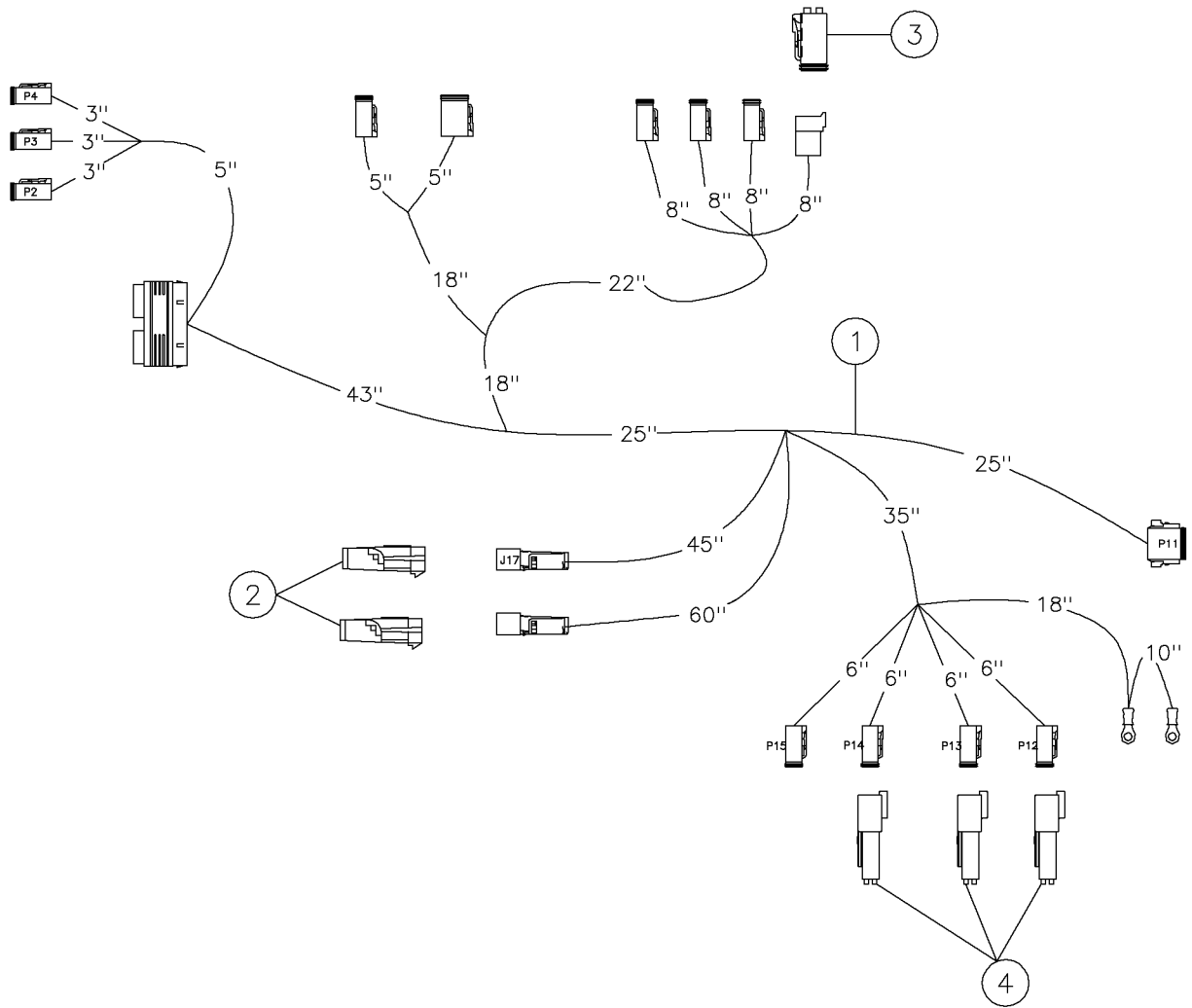

## Harness-Engine Bay Fig 9-21

REF. NO.	*	PART NO.	DESCRIPTION	QTY.	REMARKS
1		296269652	WIRE HARNESS - ENGINE BAY HYDRAULICS	1	
2		501671001	CAP-WEATHER, 4-WAY FEMALE	2	
3		296286487	SEALING PLUG- DT06-4S	1	
4		296286486	RECEPTACLE W/SEAL PLUGS- DT04-2P	4	

Harness-Thrust, Slowdown, Stop, Crash-10' Fig 9-22

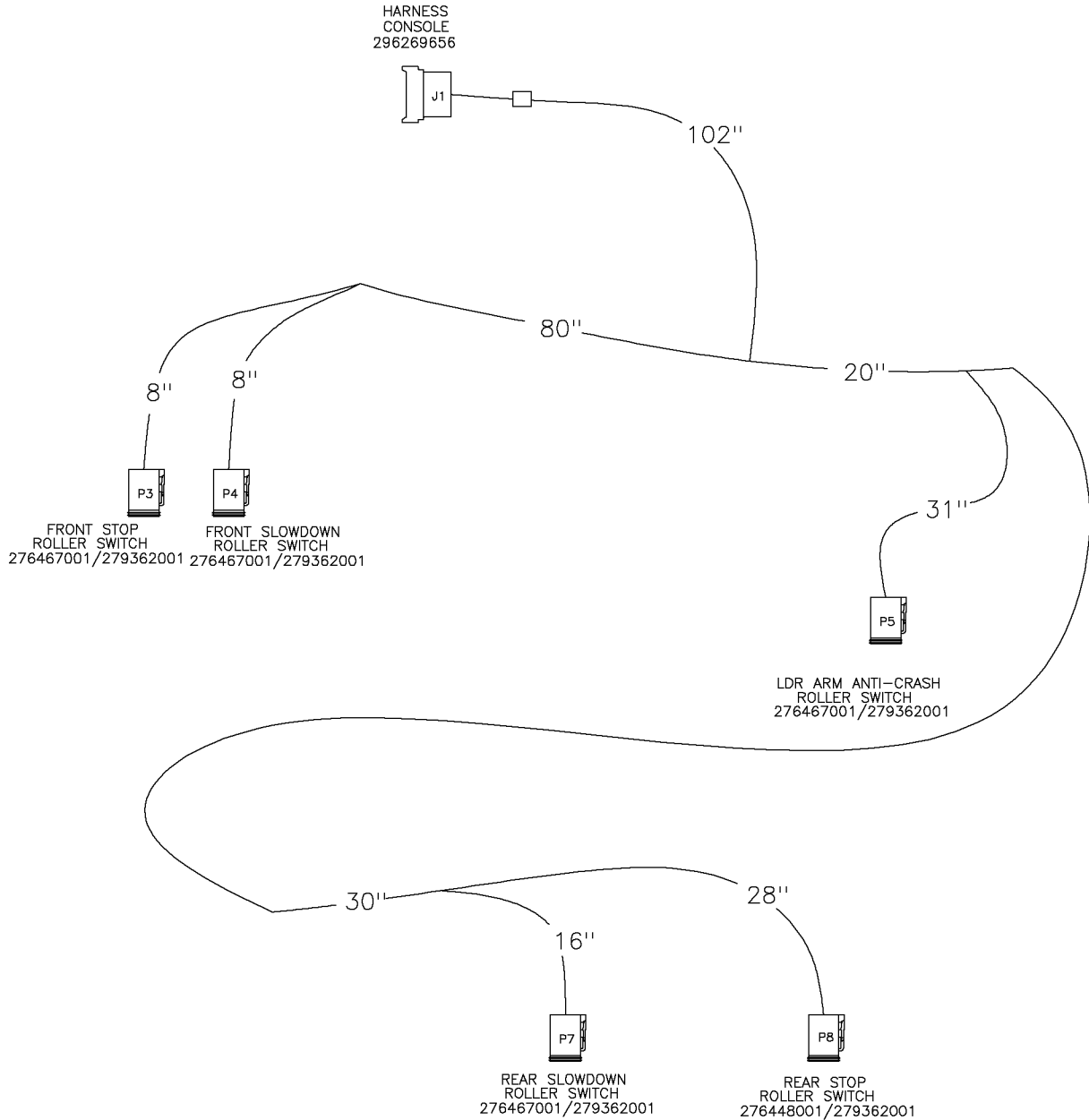

Harness-Thrust, Slowdown, Stop, Crash-10' Fig 9-22

REF. NO.	*	PART NO.	DESCRIPTION	QTY.	REMARKS
		296287988	WIRE HARNESS-THRUST CARRIAGE, ANTICRASH		

Harness-Thrust, Slowdown, Stop, Crash-15' Fig 9-23

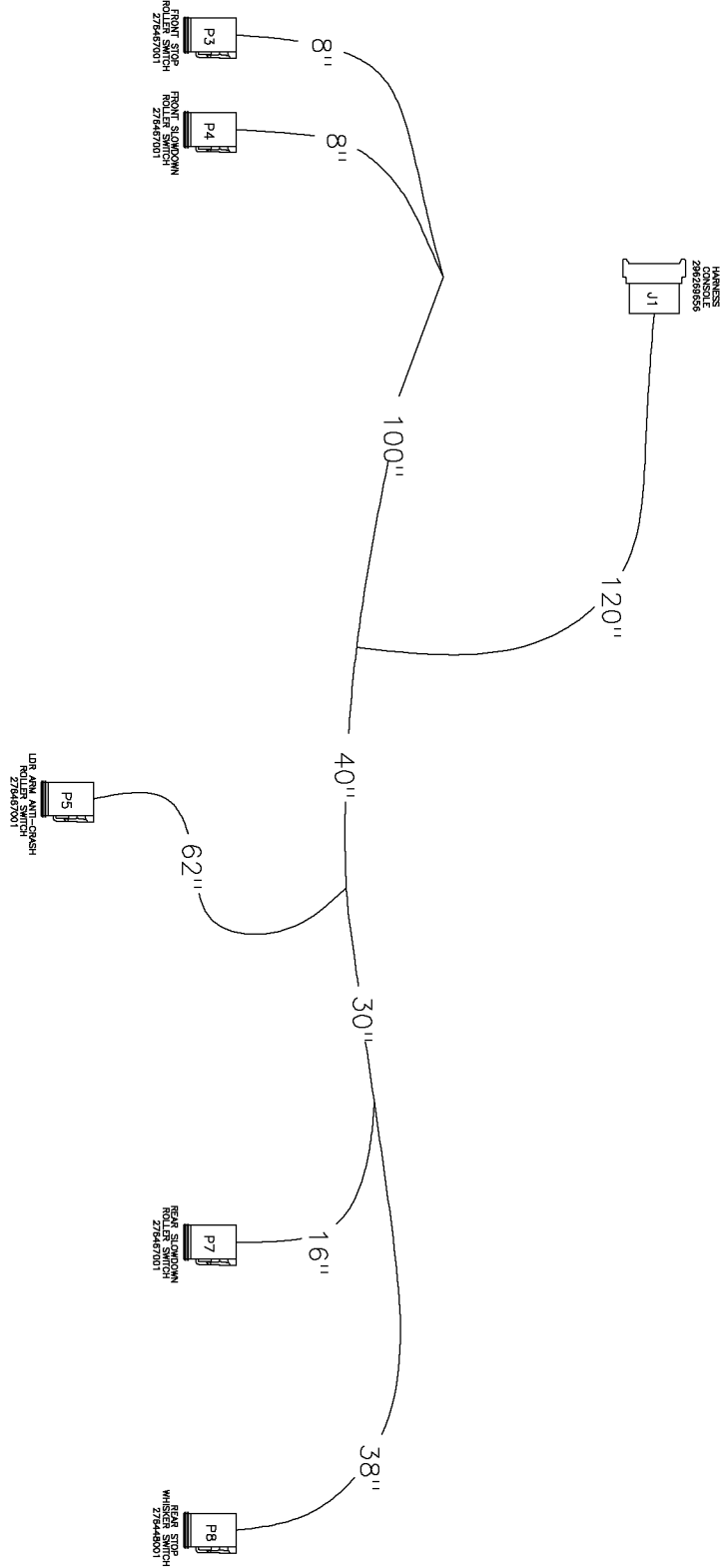



Harness-Thrust, Slowdown, Stop, Crash-15' Fig 9-23

REF. NO.	*	PART NO.	DESCRIPTION	QTY.	REMARKS
		296293086	WIRE HARNESS-THRUST CARRIAGE, ANTI-CRASH	1	

Harness-Outrigger, Fuel, H2O, Rod Loader Fig 9-24

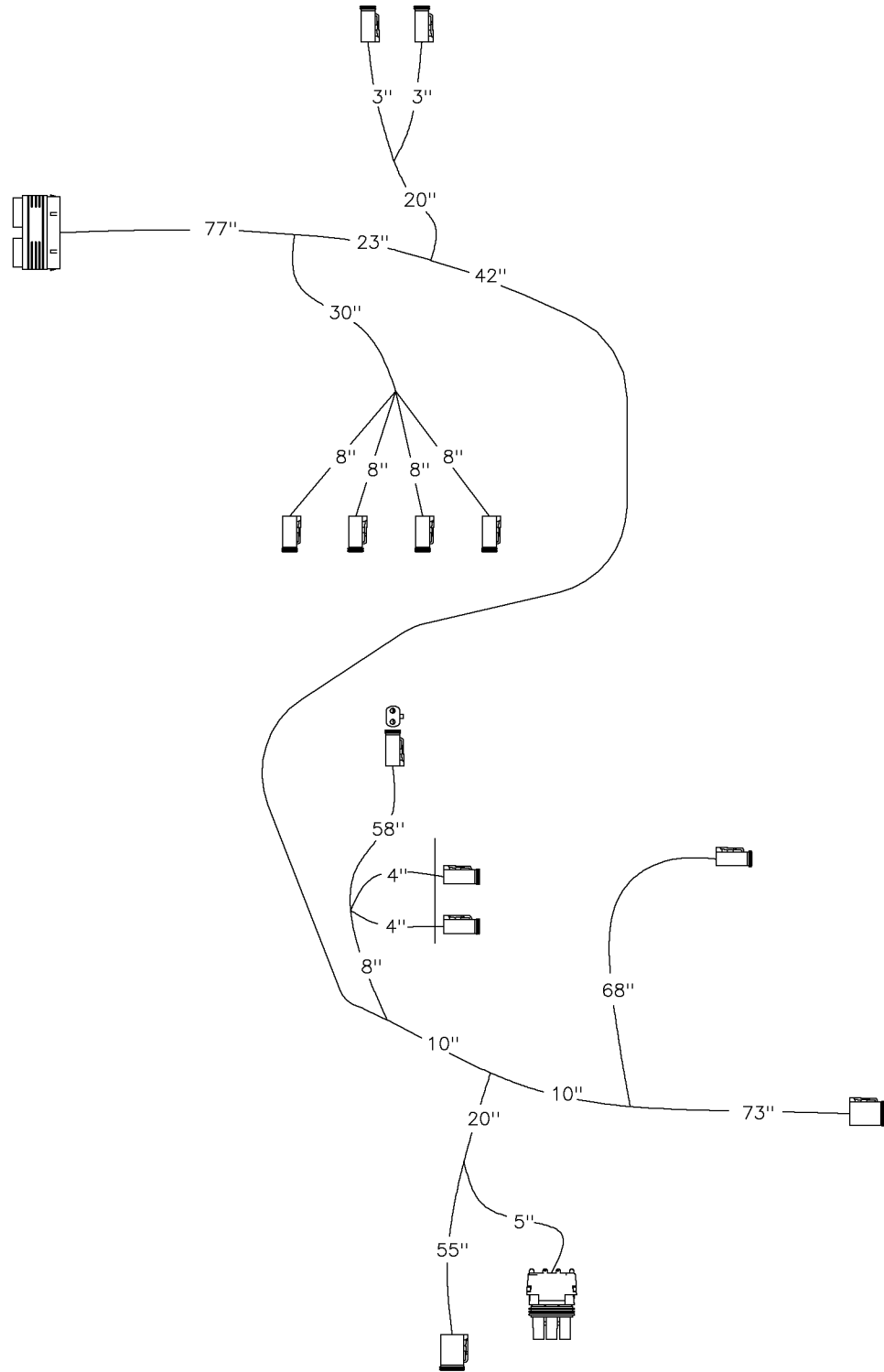

Harness-Outrigger, Fuel, H2O, Rod Loader Fig 9-24

REF. NO.	*	PART NO.	DESCRIPTION	QTY.	REMARKS
		296269654	WIRE HARNESS - OUTRIGGER,FUEL,LDR FXN	1	

Harness-stakedown, Vise, Grease, Lights Fig 9-25

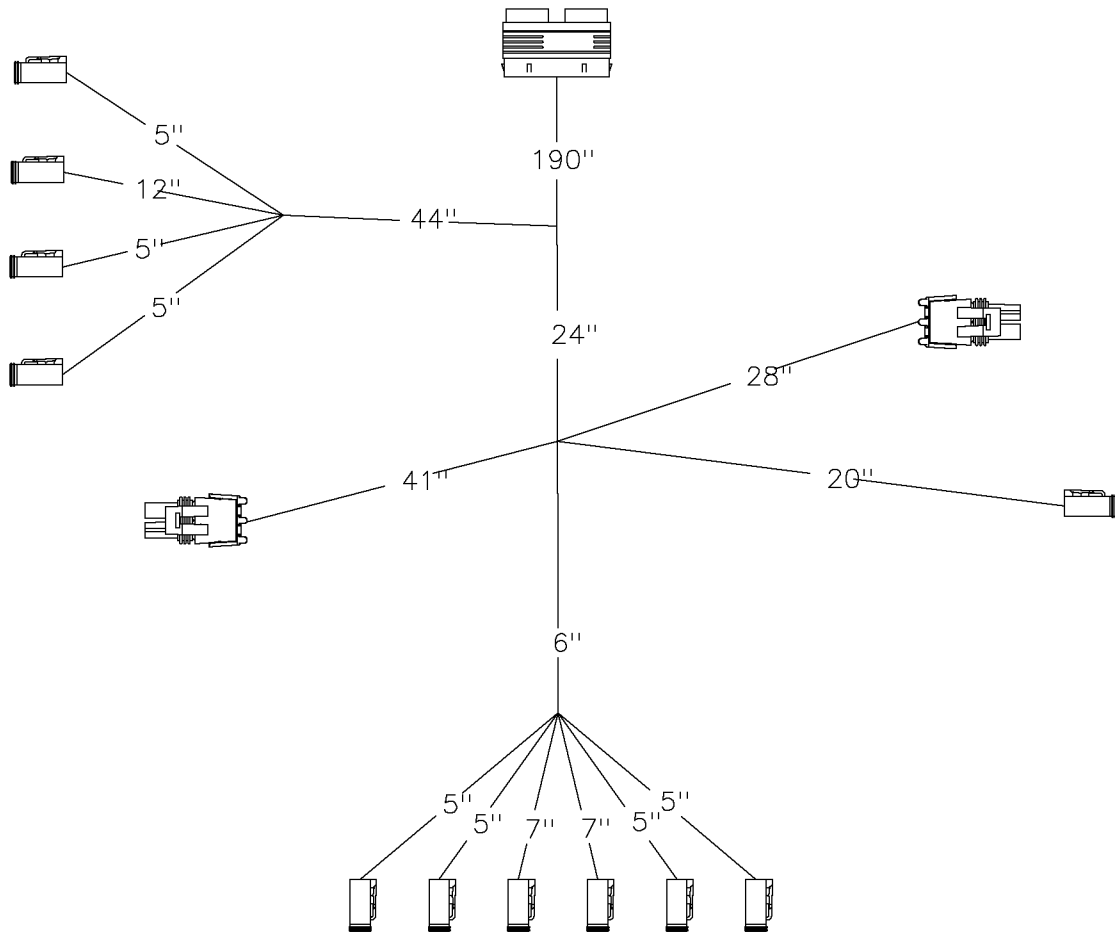

Harness-stakedown, Vise, Grease, Lights Fig 9-25

REF. NO.	*	PART NO.	DESCRIPTION	QTY.	REMARKS
		296269571	WIRE HARNESS-STKDWN,VSIE,GREASER,LIGHTS	1	

Harness-Console D24/D36 Fig 9-26

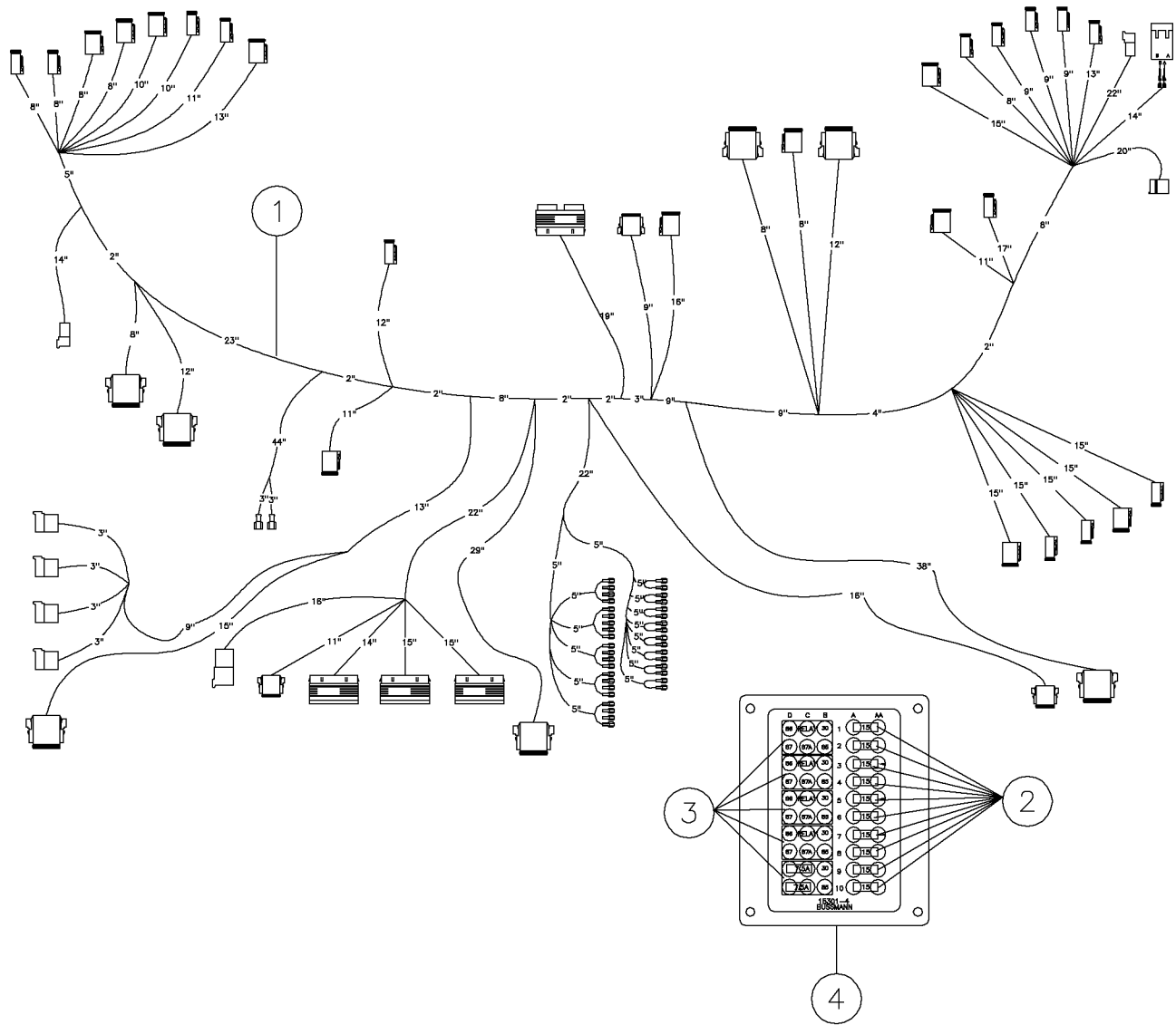

## Harness-Console D24/D36 Fig 9-26

REF. NO.	*	PART NO.	DESCRIPTION	QTY.	REMARKS
1		296286481	HARNESS - CONSOLE - D24/D36	1	
		296302409	FUSE BOX COVER	1	Not Shown
2		296285130	THERMAL BREAKER	12	
3		296277636	RELAY-MICRO 280 SERIES	5	
4		296273500	FUSE/RELAY BLOCK	1	

Harness-Strike Alert Fig 9-27

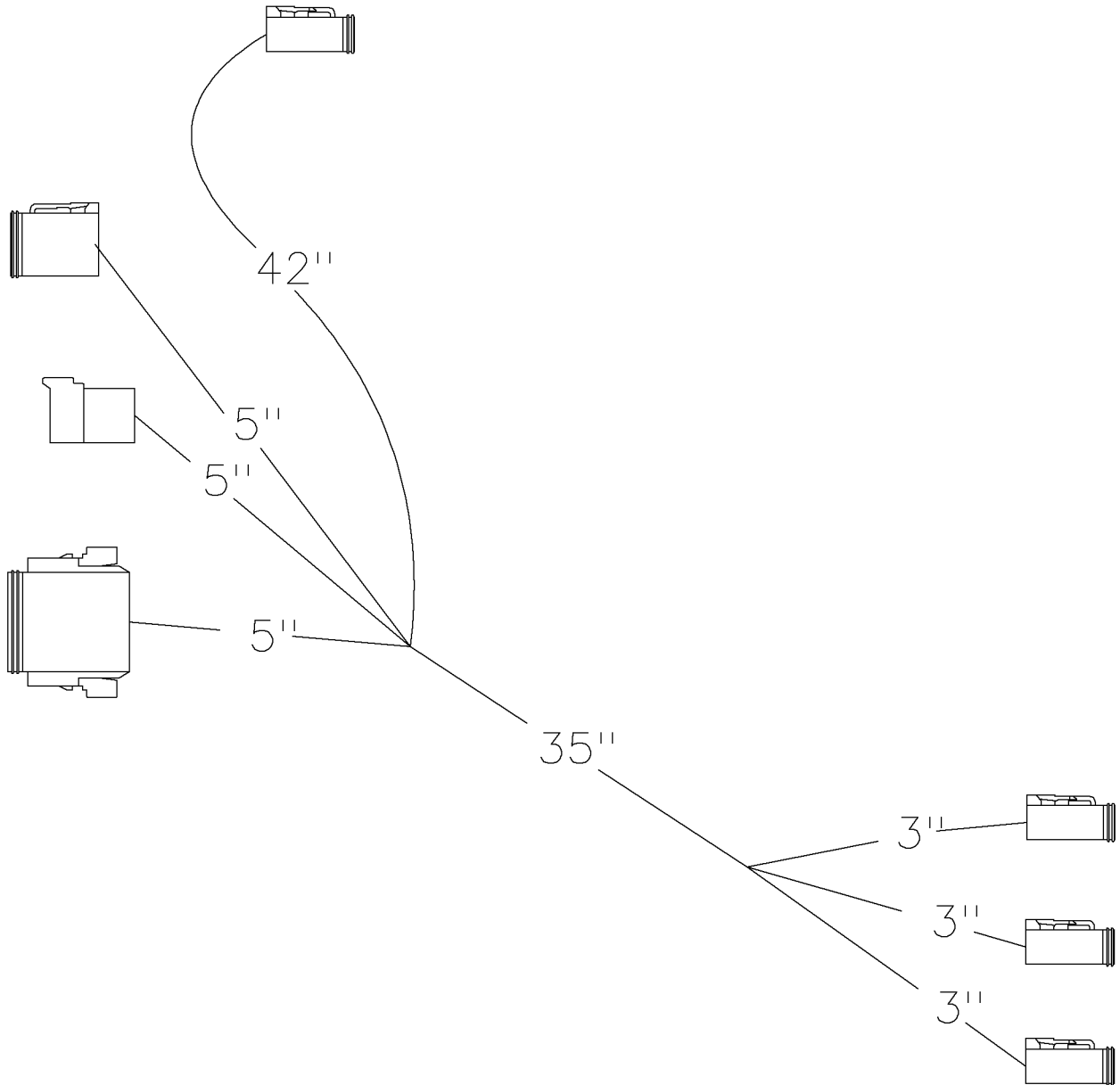



Harness-Strike Alert Fig 9-27

REF. NO.	*	PART NO.	DESCRIPTION	QTY.	REMARKS
1		296269658	WIRE HARNESS - ZAP ALERT HARNESS	1	

Harness-Hose Track/Strike Alert Fig 9-28

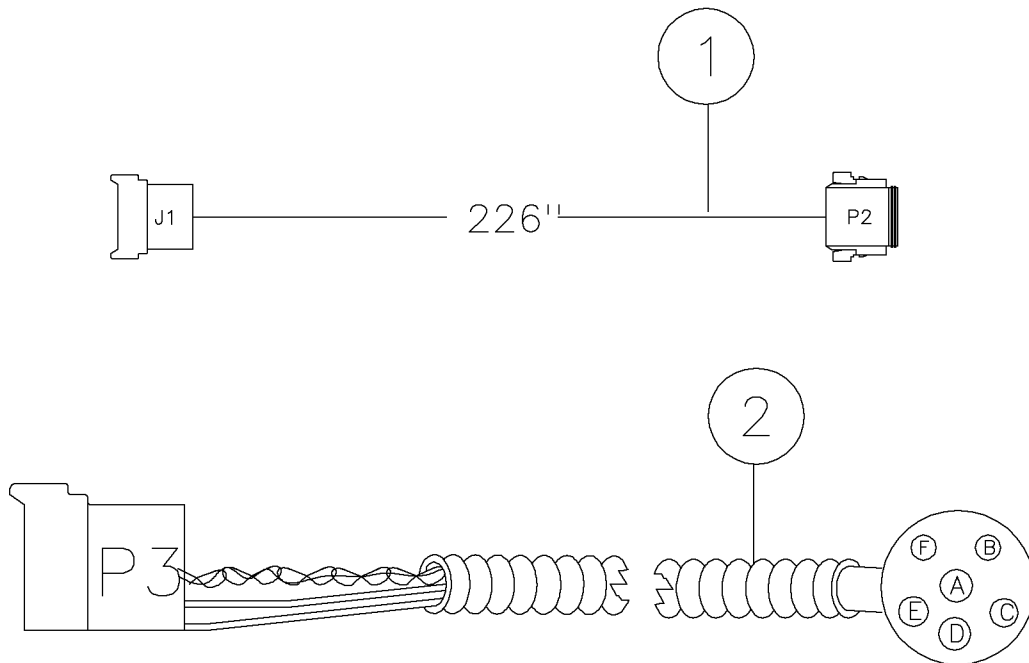

## Harness-Hose Track/Strike Alert Fig 9-28

REF. NO.	*	PART NO.	DESCRIPTION	QTY.	REMARKS
1		296269651	WIRE HARNESS - HOSE TRACK	1	
2		296280266	WIRE HARNESS-STRIKE ALERT COIL	1	

Harness-Start Relay, Power Fig 9-29

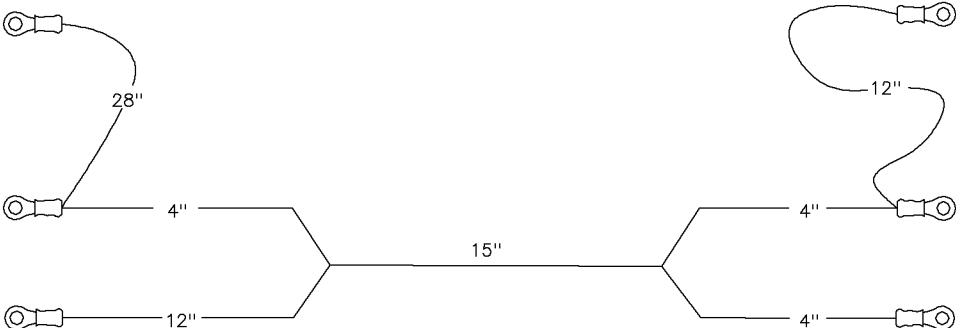

Harness-Start Relay, Power Fig 9-29

REF. NO.	*	PART NO.	DESCRIPTION	QTY.	REMARKS
		296287978	WIRE HARNESS STARTER RELAY, POWER	1	

Harness-Main Power Fig 9-30



Harness-Main Power Fig 9-30

REF. NO.	*	PART NO.	DESCRIPTION	QTY.	REMARKS
		296269637	WIRE HARNESS - MAIN POWER	1	

Harness-Ground Lead Fig 9-31

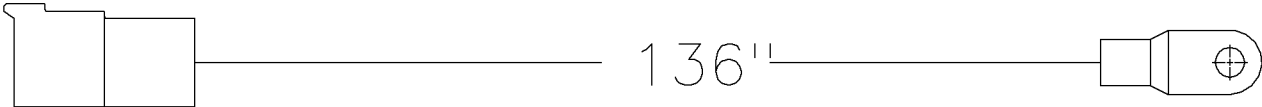



Harness-Ground Lead Fig 9-31

REF. NO.	*	PART NO.	DESCRIPTION	QTY.	REMARKS
		296269705	HARNESS - GROUND LEAD	1	

Harness-Remote Lockout Fig 9-32

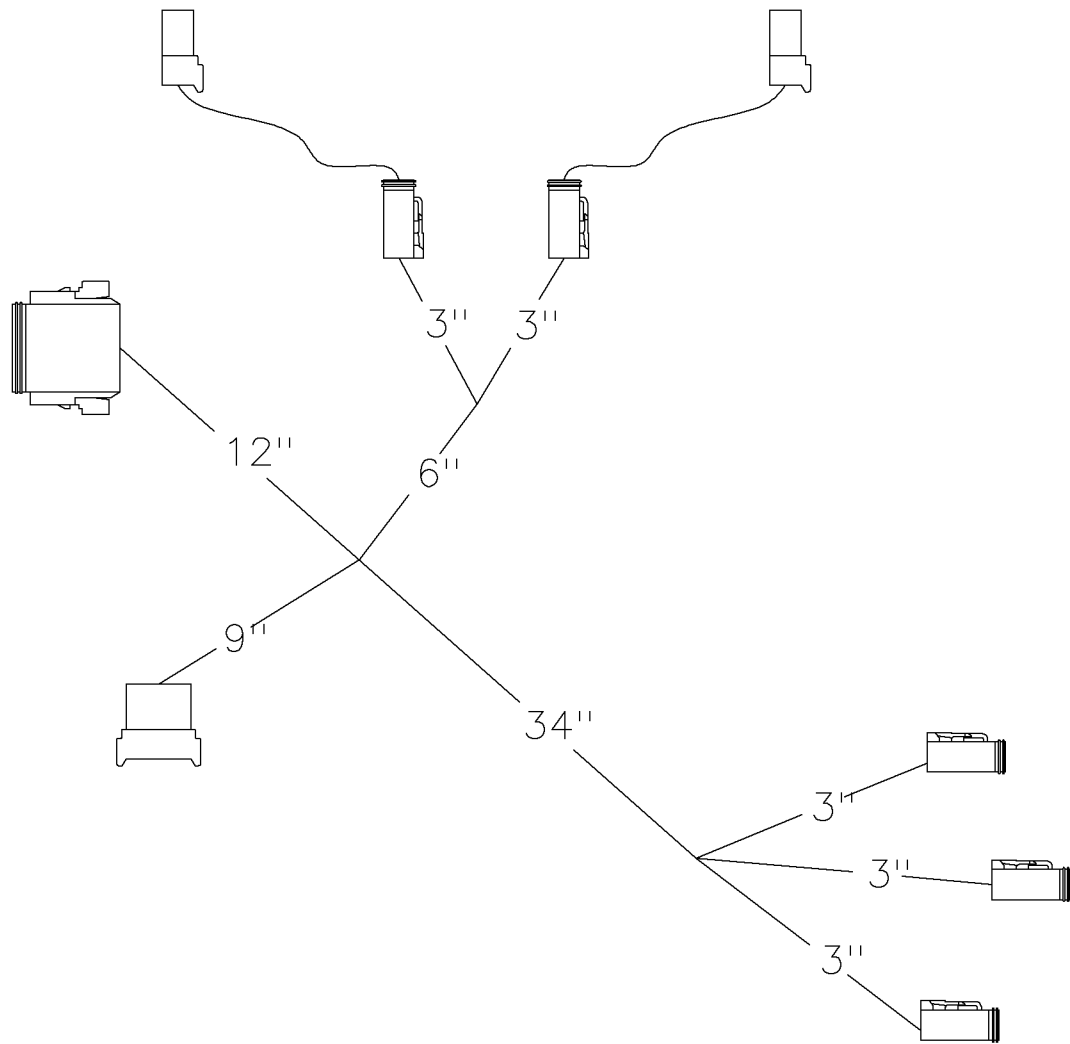

Harness-Remote Lockout Fig 9-32

REF. NO.	*	PART NO.	DESCRIPTION	QTY.	REMARKS
		296269663	WIRE HARNESS - REMOTE LOCKOUT	1	

Harness-Jumper Fig 9-33

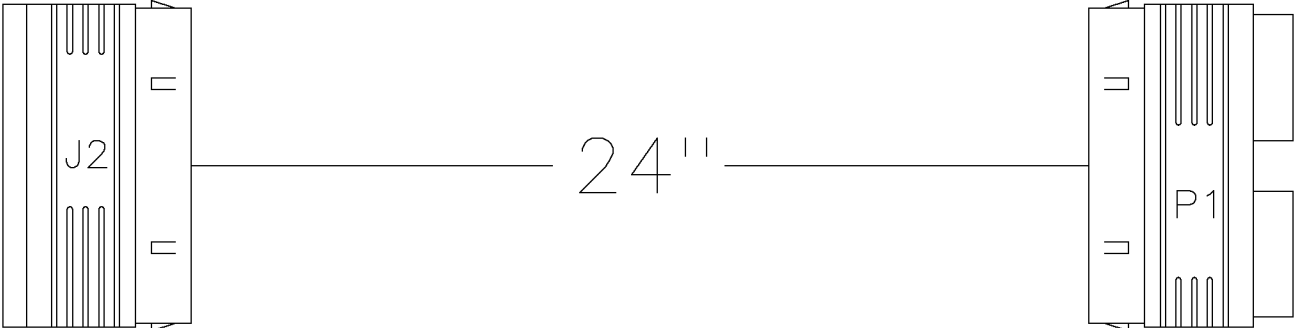

Harness-Jumper Fig 9-33

REF. NO.	*	PART NO.	DESCRIPTION	QTY.	REMARKS
		296269655	WIRE HARNESS - JUMPER	1	

Harness-Thrust/Rotation Pressure Sensor Fig 9-34

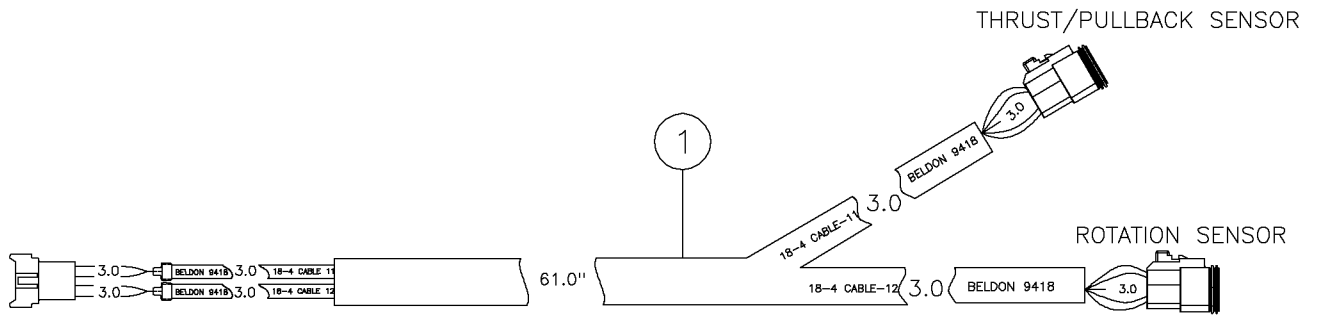

Harness-Thrust/Rotation Pressure Sensor Fig 9-34

REF. NO.	*	PART NO.	DESCRIPTION	QTY.	REMARKS
1		296286491	HARNESS - THRUST/ROT.PRESSURE SENSOR	1	

Harness-Rotation/Thrust EDC Fig 9-35

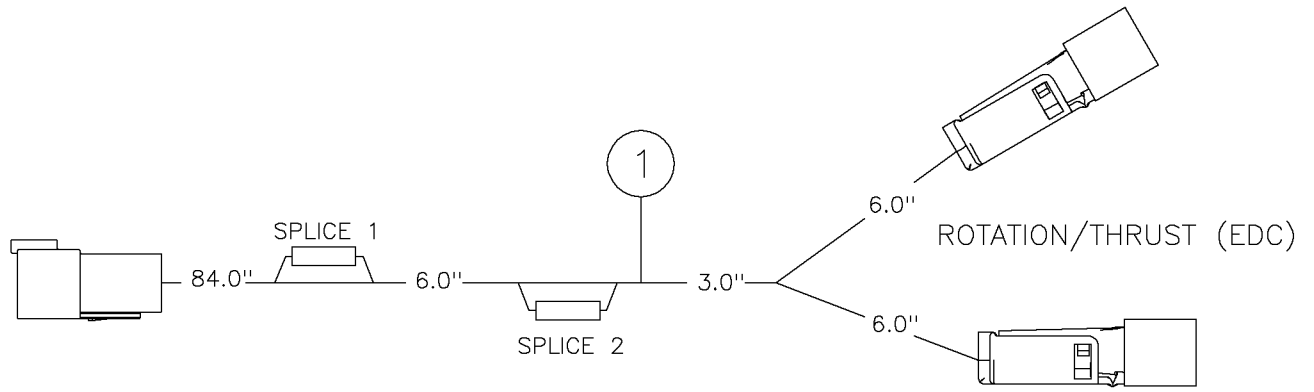



Harness-Rotation/Thrust EDC Fig 9-35

REF. NO.	*	PART NO.	DESCRIPTION	QTY.	REMARKS
1		296286492	HARNESS - ROT/THRUST EDC	1	

Harness-Mud Pump (PPU) Fig 9-36

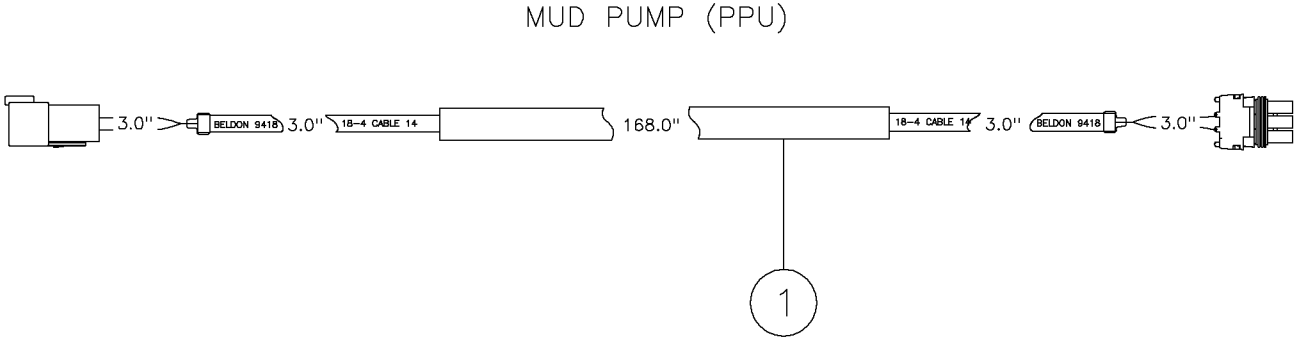

Harness-Mud Pump (PPU) Fig 9-36

REF. NO.	*	PART NO.	DESCRIPTION	QTY.	REMARKS
1		296286493	HARNESS - MUD PUMP PPU	1	

Harness-Mud Pump (PWM) Fig 9-37

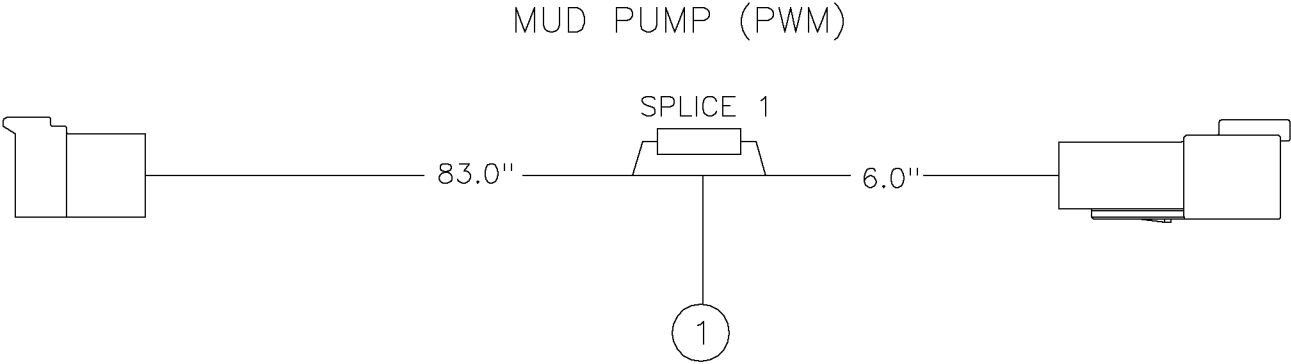

Harness-Mud Pump (PWM) Fig 9-37

REF. NO.	*	PART NO.	DESCRIPTION	QTY.	REMARKS
1		296286494	HARNESS - MUD PUMP PWM	1	

Harness-Rotation (PPU) Fig 9-38

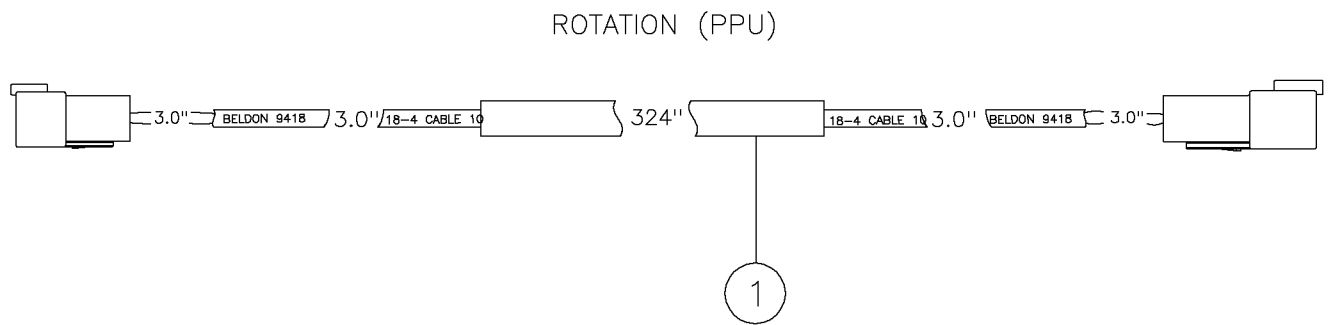

Harness-Rotation (PPU) Fig 9-38

REF. NO.	*	PART NO.	DESCRIPTION	QTY.	REMARKS
1		296286495	HARNESS - ROTATION (PPU)	1	

Harness-Controller Fig 9-39

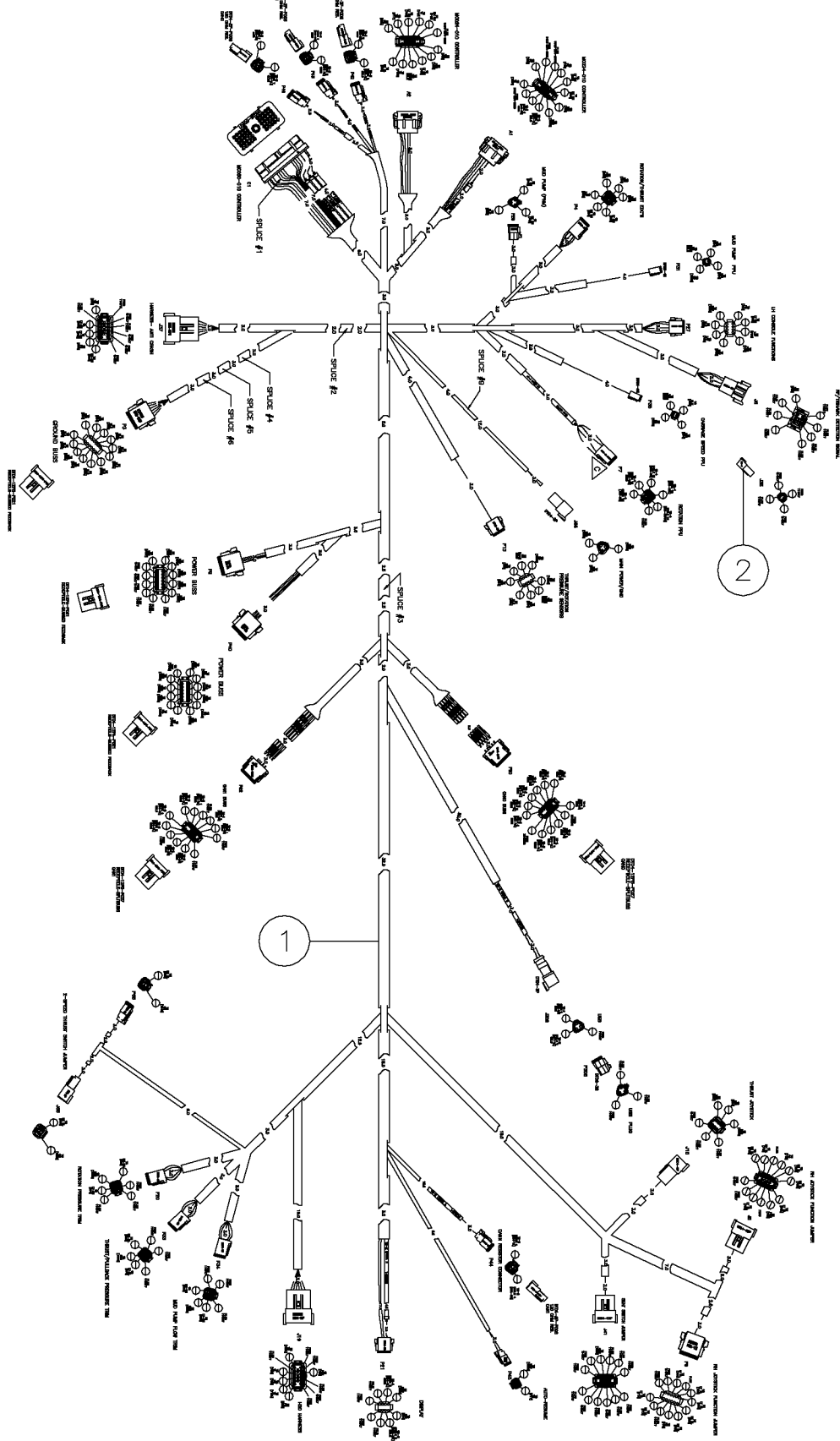



## Harness-Controller Fig 9-39

REF. NO.	*	PART NO.	DESCRIPTION	QTY.	REMARKS
1		296286455	HARNESS - CONTROLLER	1	
2		296286488	RECEPTACLE W/SEAL PLUGS-DT04-4P	1	

Harness-LH Console Fig 9-40

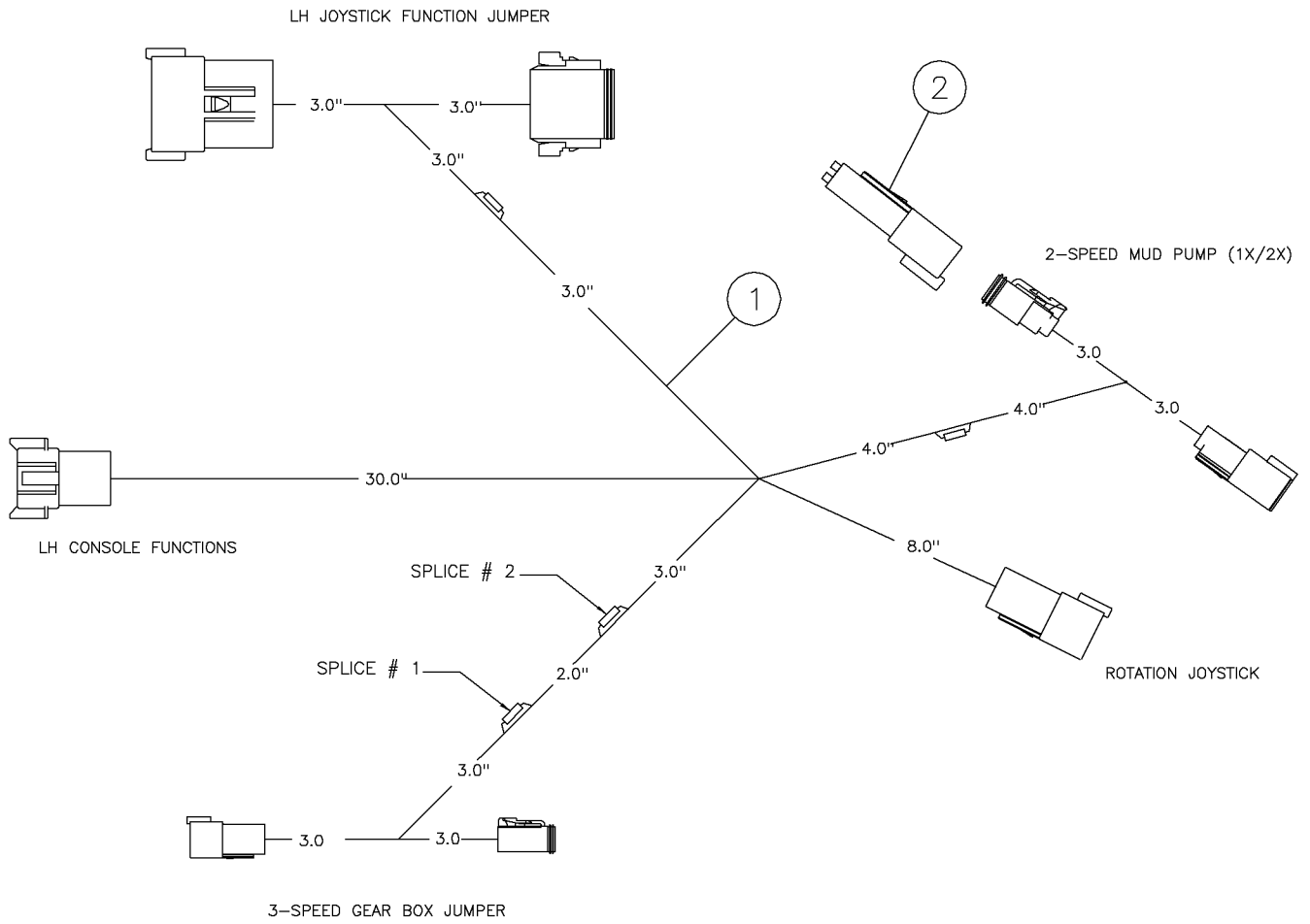

Harness-LH Console Fig 9-40

REF. NO.	*	PART NO.	DESCRIPTION	QTY.	REMARKS
1		296286500	HARNESS - LH CONSOLE	1	
2		296286486	RECEPTACLE W/SEAL PLUGS- DT04-2P	1	

Harness-Rotation Limiter Relay Fig 9-41

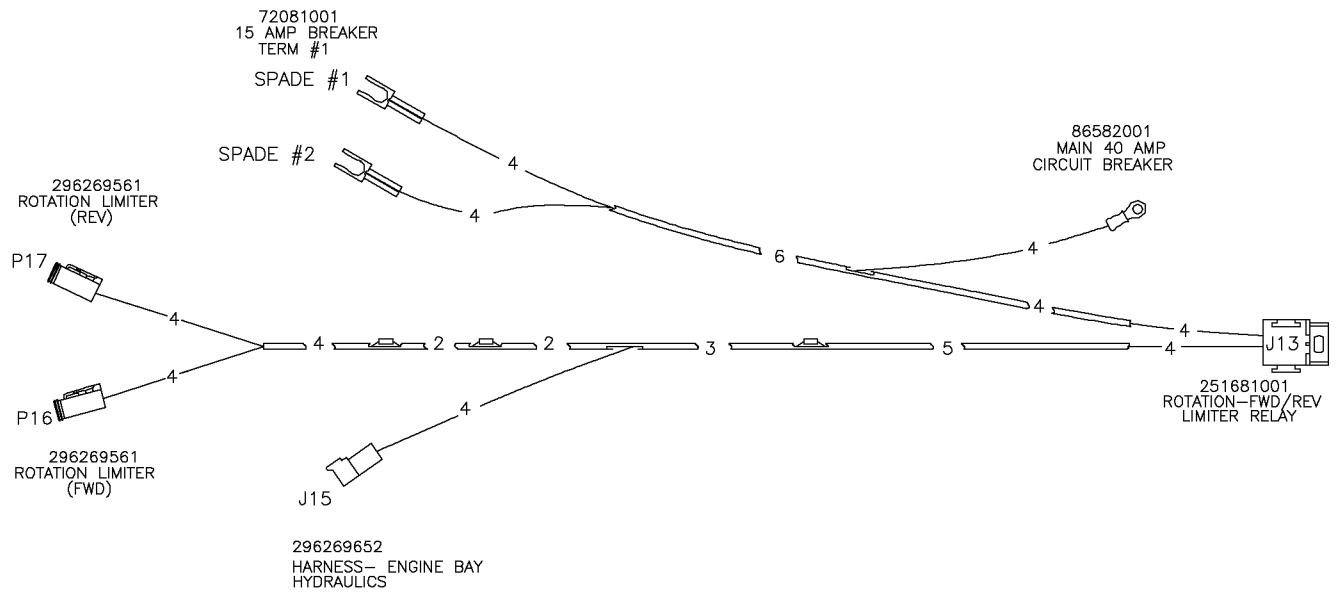

Harness-Rotation Limiter Relay Fig 9-41

REF. NO.	*	PART NO.	DESCRIPTION	QTY.	REMARKS
		296286474	HARNESS-ROTATION LIMITER RELAY	1	

Harness-Power Distribution Fig 9-42

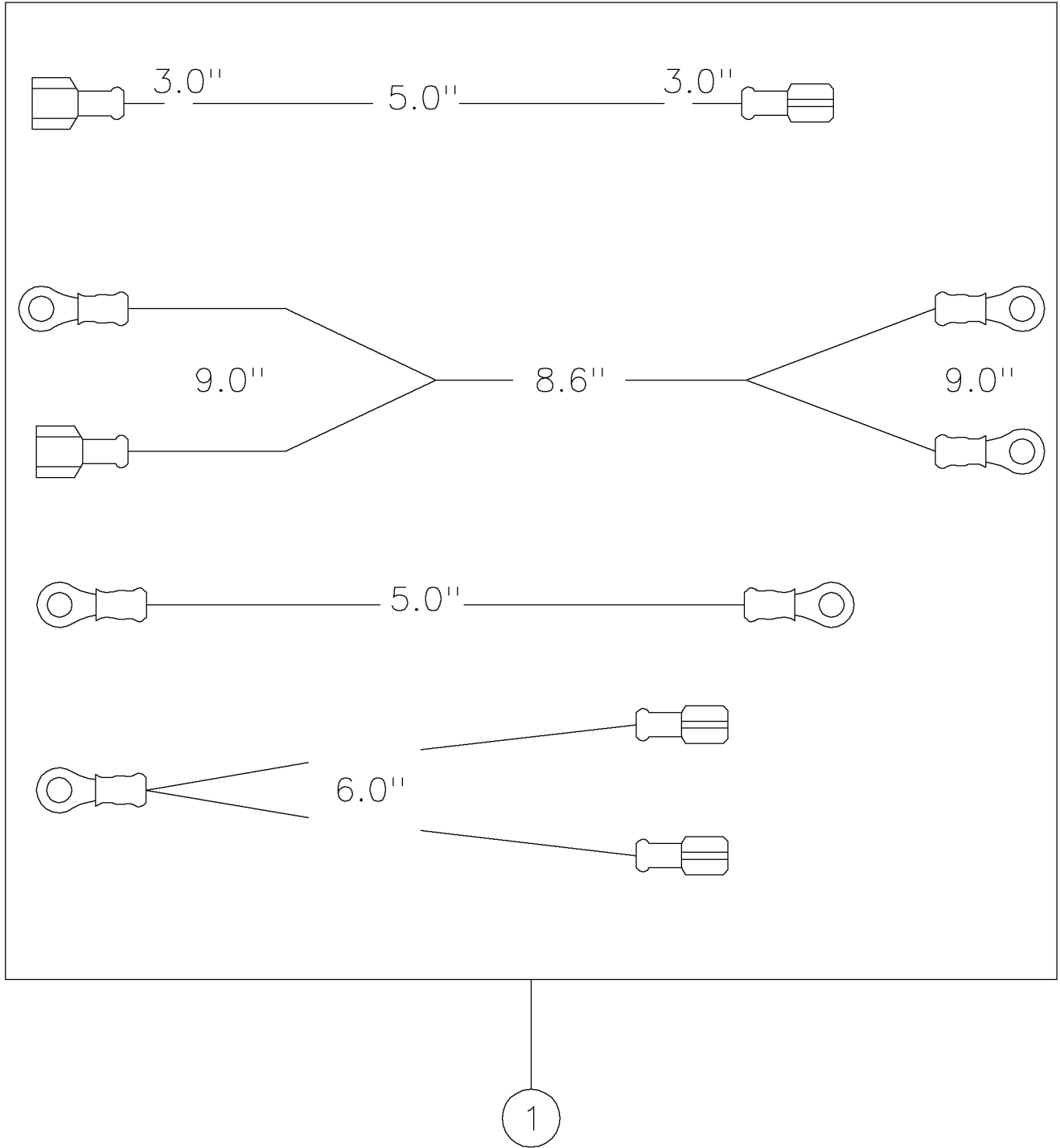

Harness-Power Distribution Fig 9-42

REF. NO.	*	PART NO.	DESCRIPTION	QTY.	REMARKS
1		296298827	POWER DISTRIBUTION	1	

Power Relay Fig 9-43

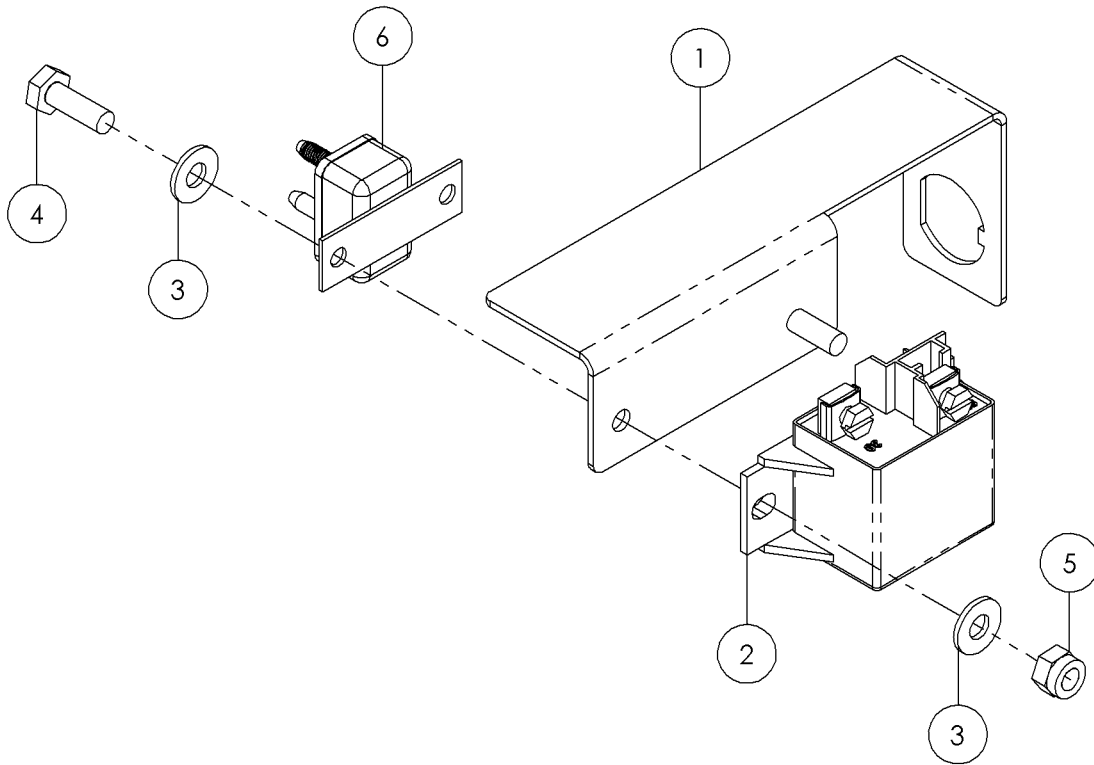

Illustration No. 296269717



## Power Relay Fig 9-43

REF. NO.	*	PART NO.	DESCRIPTION	QTY.	REMARKS
1		296298785	PLATE - POWER RELAY WITH MFD-USA/ 13" ANTENNA	1	
2		86217001	RELAY-BOSCH SPST 75 AMP SEALED	1	
3		235716001	WASHER - FLATSTRL - .25 -.28 X .63 - .06 - CZ	4	
4		235734001	BOLT-1/4-20X3/4 GR8 ZYC	2	
5		103201001	NUT-1/4-20NC NYLON INSERT LOCK	2	
6		86582001	*BREAKER-40A TYPE 1 W/METALCASE	1	

Harness-Vise Check Valve Fig 9-44

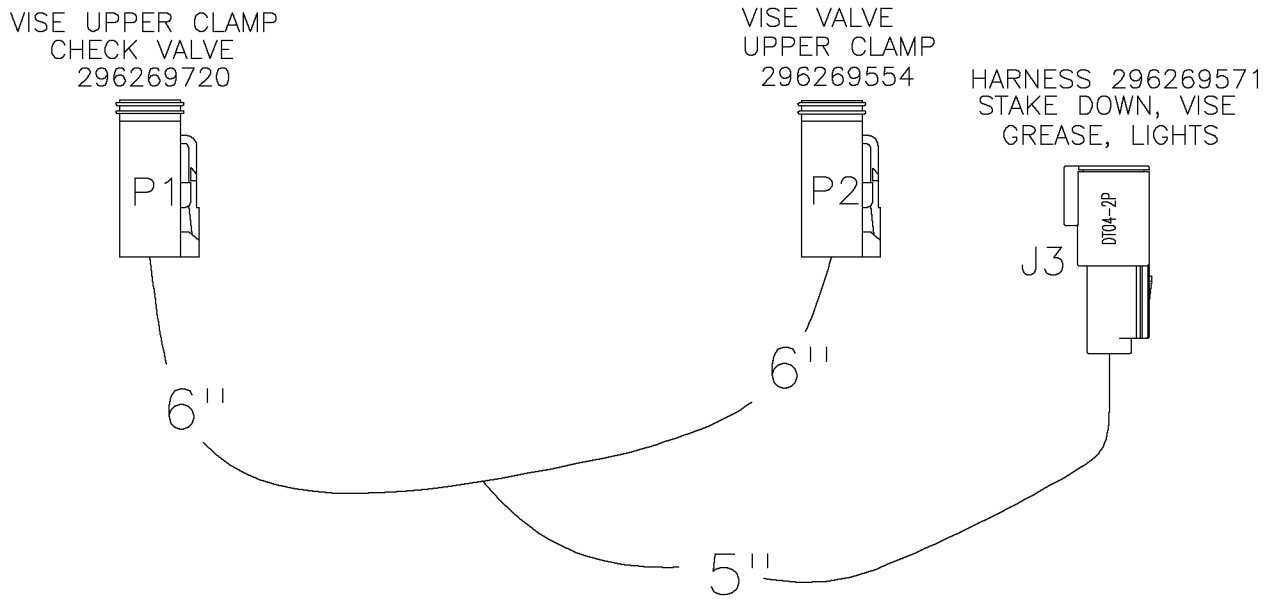

Harness-Vise Check Valve Fig 9-44

REF. NO.	*	PART NO.	DESCRIPTION	QTY.	REMARKS
		296269721	WIRE HARNESS - VICE CHECK VALVE	1	

Harness-Neutral Ground Jumper Fig 9-45

GROUND TO MACHINE FRAME



3"



47"

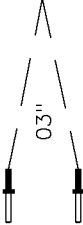

0.3"

TO GND BLOCK P4 CONN.

Harness-Neutral Ground Jumper Fig 9-45

REF. NO.	*	PART NO.	DESCRIPTION	QTY.	REMARKS
		296298792	NEUTRAL GND JUMPER D24 & D36 SERIES II	1	

Voltage Stake Fig 10-1

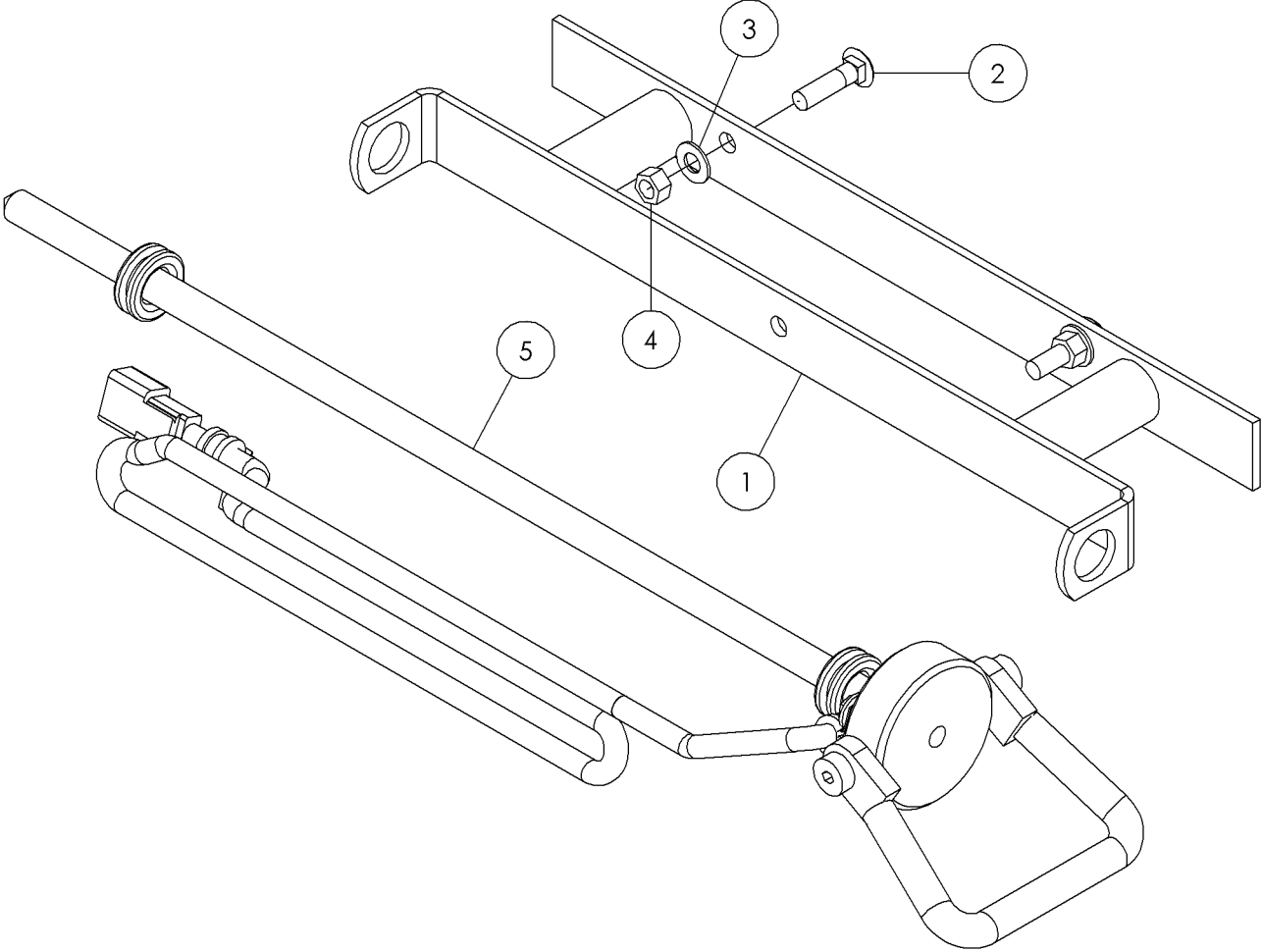

Illustration No. 296280891

## Voltage Stake Fig 10-1

REF. NO.	*	PART NO.	DESCRIPTION	QTY.	REMARKS
1		240791001	BRACKET-VOLTAGE STAKE	1	
2		510308114	BOLT-CARG-.38-16X1.50-GR5-YZ	2	
3		235713001	WASHER-FLATSTRL-.38-.41X.81-.06-YA-A325	2	
4		235725001	NUT - HEX - .38 - 16 - GR8 - YZ	2	
5		296273406	ASSEMBLY - VOLTAGE STAKE	1	Breakdown Fig. 10-2

Components-Voltage Stake Fig 10-2

Illustration No. 296273406

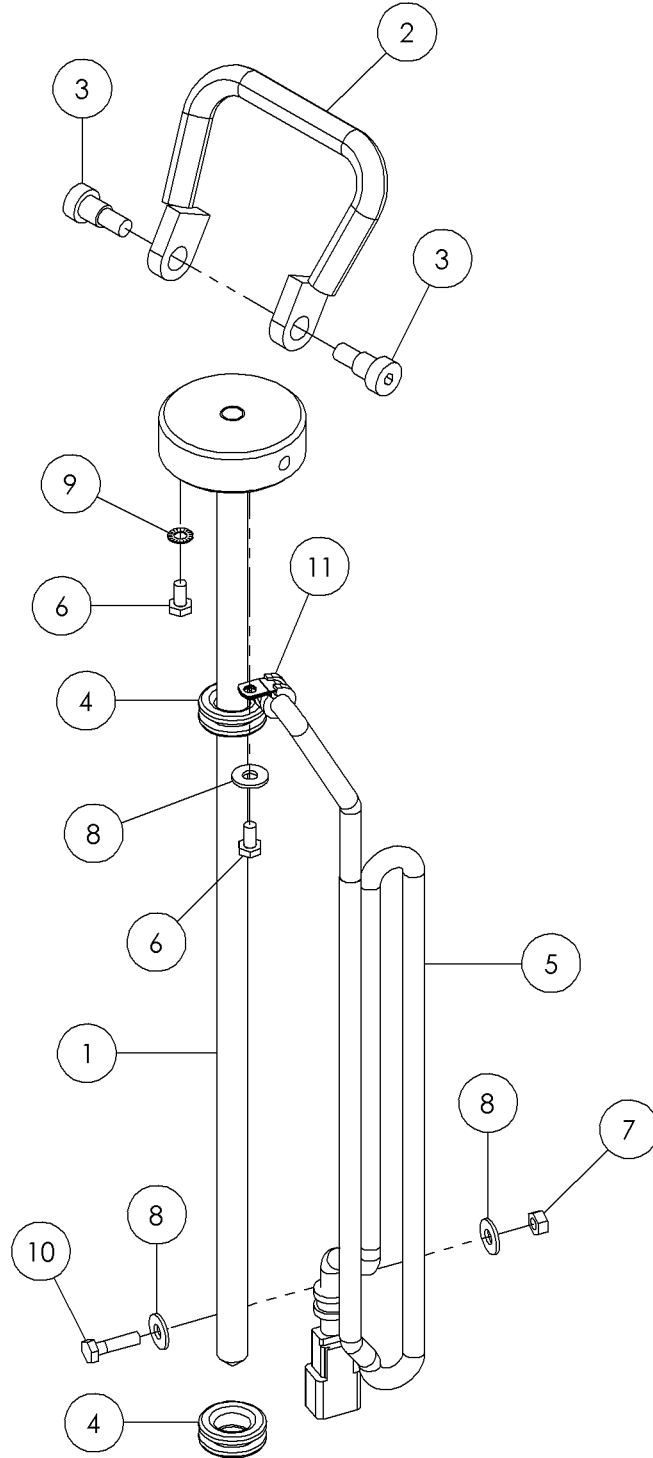



Components-Voltage Stake Fig 10-2

REF. NO.	*	PART NO.	DESCRIPTION	QTY.	REMARKS
1		296275119	STAKE-VOLTAGE	1	Breakdown Fig. 10-3
2		234164001	HANDLE-VOLTAGE STAKE	1	
3		240056001	SCREW-SHSS-.50X.50-.38-16THD-CZ	2	
4		1865043	GROMMET-.75IDX1.38OD-.19GROOVE	2	
5		296275117	HARNESS-VOLTAGE STAKE	1	
6		235733001	BOLT-1/4-20X1/2 GR8 ZYC	3	
7		235732001	NUT - HEX - .25 - 20 - GR8 - YZ	1	
8		510337603	WASHER-FLATSTD-.25-.31X.75-.07-YZ	3	
9		481013	WASHER-1/4 EST. STAR	2	
10		235735001	BOLT-1/4-20X1 GR8 HEX ZYC	1	
11		296275118	CLAMP - #8	2	

Components-Voltage Stake Fig 10-3

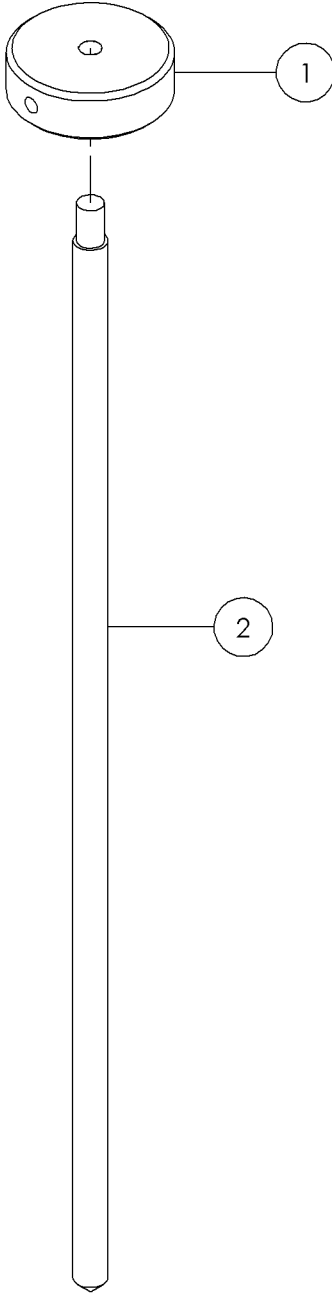
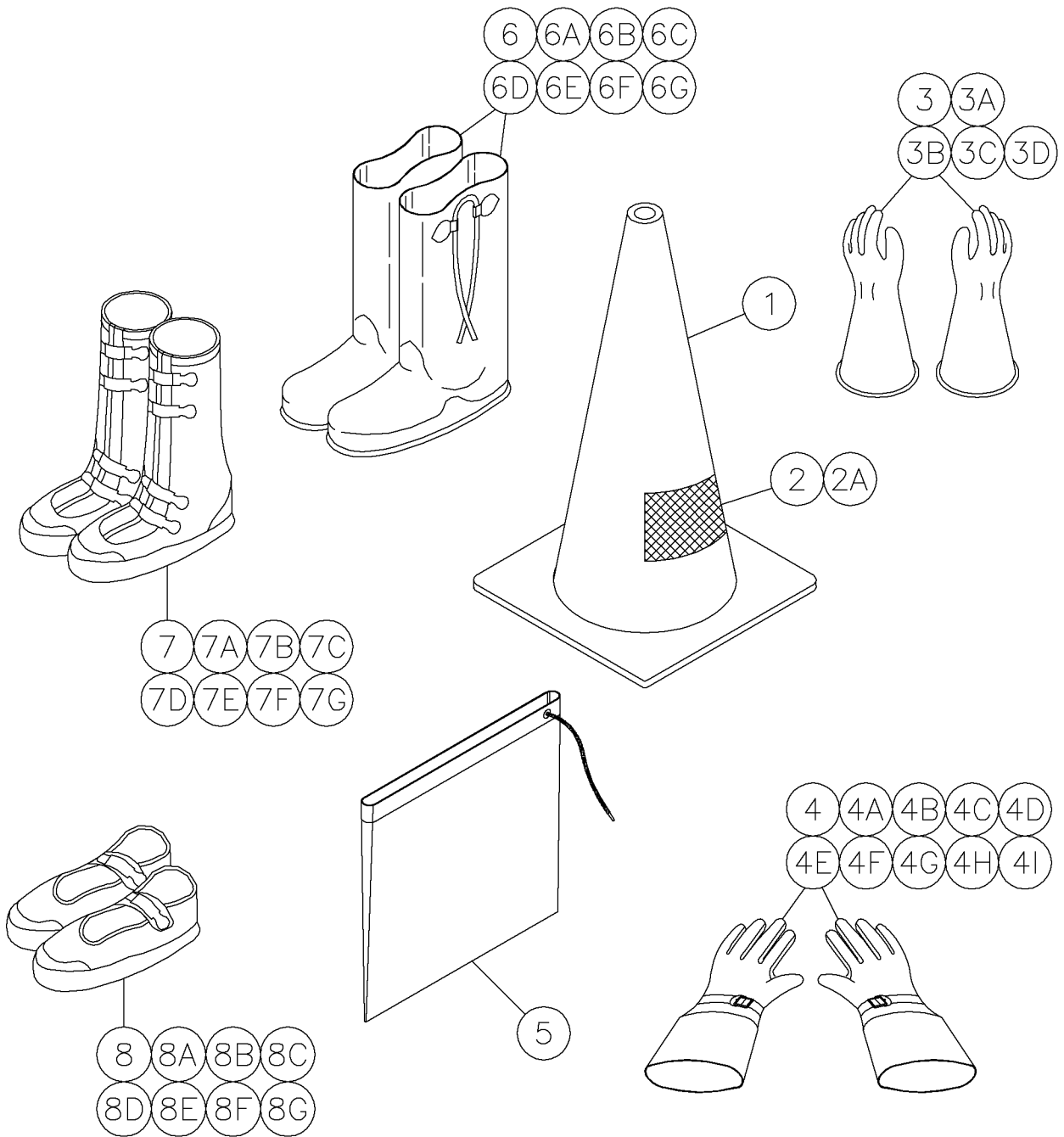

Illustration No. 296275119

Components-Voltage Stake Fig 10-3

REF. NO.	*	PART NO.	DESCRIPTION	QTY.	REMARKS
1		296275107	HEAD - VOLTAGE STAKE	1	
2		904155001	VOLTAGE STAKE	1	

Safety Features Fig 10-4



## Safety Features Fig 10-4

REF. NO.	*	PART NO.	DESCRIPTION	QTY.	REMARKS
1		277788001	*WARNING CONE ASS'Y	4	Includes Ref. #2
2		70000530	*DECAL-DANGER	4	Domestic
2A		70001530	*DECAL- DANGER	4	International
3		210782001	GLOVES-SIZE 9 RUBBER INSULATE	1	
3A		210782005	GLOVES-SIZE 9 1/2 RUBBER INSUL (PAIR)	1	
3B		210782003	GLOVES-SIZE 10 RUBBER INS (PAIR)	1	
3C		210782007	GLOVE-SIZE 11 RUBBER INSULATED	1	
3D		210782009	GLOVE-SIZE 12 RUBBER INSULATED	1	
4		210783001	GLOVES-SIZE 9 LEATHER PROTECT (PAIR)	1	
4A		210783005	GLOVES SIZE 9 1/2 LEATHER PROT (PAIR)	1	
4B		210783003	GLOVES-SIZE 10 LEATHER PROTECT (PAIR)	1	
4C		210783007	GLOVE-SIZE 11 LEATHER PROTECT	1	
4D		210783009	GLOVE-SIZE 12 LEATHER PROTECT	1	
4E		210781001	GLOVE KIT-SIZE 9	1	Inc 1 Ea: Ref No 3 & 4, (persize) & 5
4F		224979001	GLOVE KIT-SIZE 9 1/2	1	Inc 1 Ea: Ref No 3 & 4, (persize) & 5
4G		210785001	GLOVE KIT-SIZE 10 (PAIR)	1	Inc 1 Ea: Ref No 3 & 4, (persize) & 5
4H		224990001	GLOVE KIT-SIZE 11	1	Inc 1 Ea: Ref No 3 & 4, (persize) & 5
4I		224991001	GLOVE KIT-SIZE 12	1	Inc 1 Ea: Ref No 3 & 4, (persize) & 5
5		210784001	BAG-GLOVE	1	
6		210780009	BOOTS-SIZE 9 OVER-THE-SHOE	1	
6A		210780001	BOOTS-SIZE 10 OVER-THE-SHOE	1	
6B		210780003	BOOTS-SIZE 11 OVER-THE-SHOE	1	
6C		210780005	BOOTS-SIZE 12 OVER-THE-SHOE	1	
6D		210780007	BOOTS-SIZE 13 OVER-THE-SHOE	1	
6E		210780011	BOOTS-SIZE 14 OVER-THE-SHOE	1	
6F		210780013	BOOTS-SIZE 15 OVER-THE-SHOE	1	
6G		210780015	BOOTS-SIZE 16 OVER-THE-SHOE	1	
7		279118001	BOOT - 4 BUCKLE SIZE 9	1	
7A		279118002	BOOT-4 BUCKLE SIZE 10	1	
7B		279118003	BOOT 4 BUCKLE SIZE 11	1	
7C		279118004	BOOT - 4 BUCKLE SIZE 12	1	
7D		279118005	BOOT - 4 BUCKLE SIZE 13	1	
7E		279118006	BOOT - 4 BUCKLE SIZE 14	1	
7F		279118007	BOOT - 4 BUCKLE SIZE 15	1	
7G		279118008	BOOT - 4 BUCKLE SIZE 16	1	
8		279119001	BOOT - ANKLE RUBBER SIZE9	1	
8A		279119002	BOOT - ANKLE RUBBER SIZE 10	1	
8B		279119003	BOOT - ANKLE RUBBER SIZE 11	1	
8C		279119004	BOOT - ANKLE RUBBER SIZE 12	1	
8D		279119005	BOOT - ANKLE RUBBER SIZE 13	1	
8E		279119006	BOOT - ANKLE RUBBER SIZE 14	1	
8F		279119007	BOOT - ANKLE RUBBER SIZE 15	1	
8G		279119008	BOOT - ANKLE RUBBER SIZE 16	1	
note			All Gloves & boots Are Ordered As Pair		

Water Pump-50 GPM FMC Fig 11-1

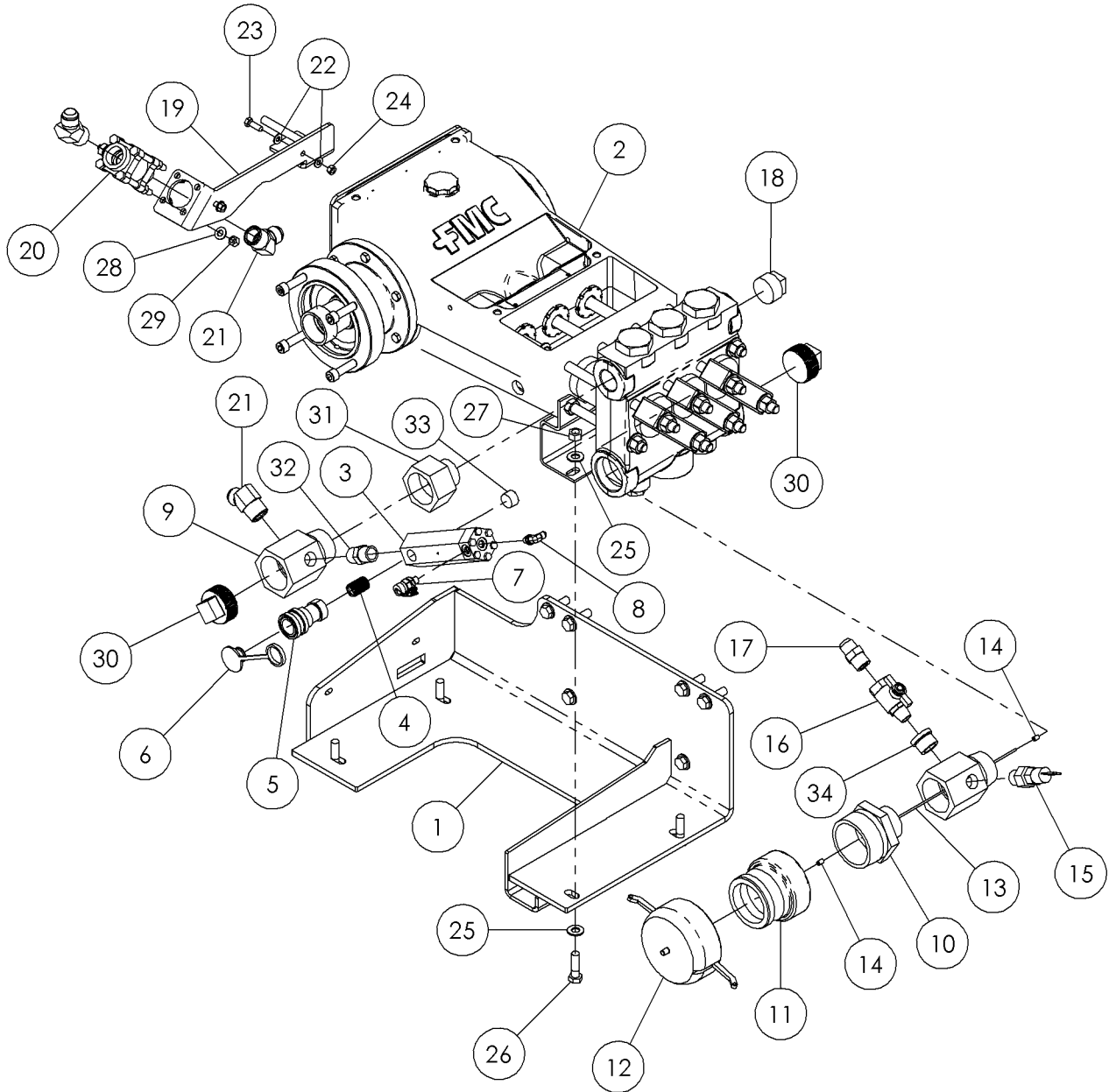
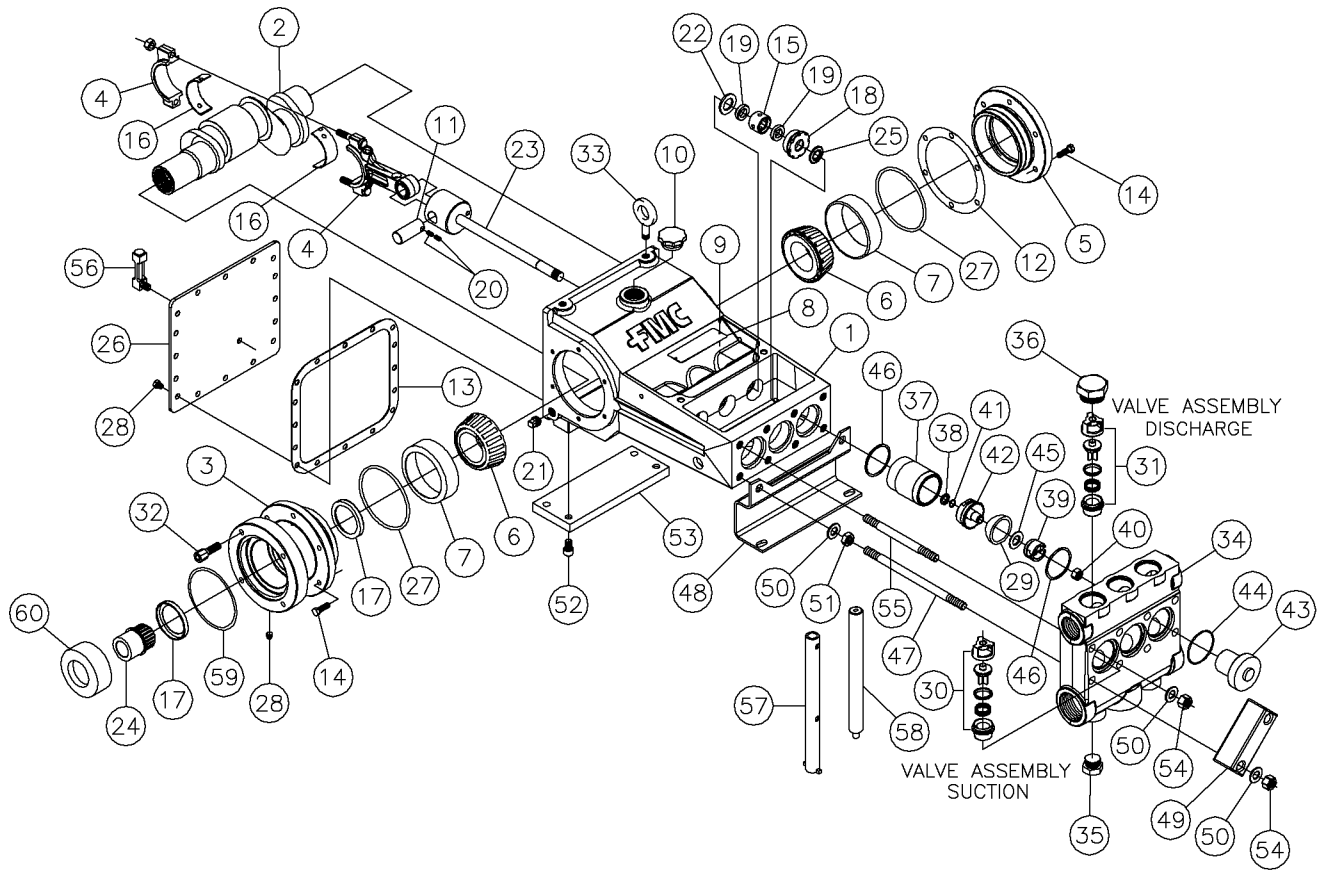

Illustration No. 296279881

## Water Pump-50 GPM FMC Fig 11-1

REF. NO.	*	PART NO.	DESCRIPTION	QTY.	REMARKS
1		296280862	PUMP SUPPORT ASY	1	
2		296269558	PUMP-FMC MUD PUMP 26.8 CID	1	Breakdown Fig. 11-1z01
3		296265854	WATER PRESSURE DUMBELL PISTON MAN.ASSY	1	Breakdown Fig. 11-1z02
4		707003	1/2" NPT HEX NIPPLE	1	
5		227235001	COUPLER-1/2"NPT QUICK(FEMALE)	1	
6		234679001	CAP-DUST	1	
7		75493001	FITTING - TEST - 4MORB - 16MTP	1	
8		59423001	90-4MORBA-4MJ	1	
9		236472001	FITTING-2"MX3/4"FX2 XCX FNPT TEE	2	
10		221506001	NIPPLE-REDUCING 3X2 MPT (POLY)	1	
11		275759001	COUPLINE-3"MTPT X3" FPT (POLY)	1	
12		215429001	CAP-3" CAM LOCK	1	
13		244069001	CABLE-3/32"X12 XCX NYLON COATED	1	
14		1838001	CONNECTOR-WIRE (ETC)	2	
15		287554001	SWITCH - 10 PSI NO/NC	1	
16		275770001	VALVE - 3/4 MXF BALL W/T-HNDL	1	
17		53836001	3/4M PIPE-#12M JIC ST.	1	
18		732015	1 1/2" PIPE PLUG BLACK STEEL	1	
19		296303781	WATER VALVE SUPPORT	1	
20		278003001	VALVE - 1" 1500 PSI BRASS BALL	1	Breakdown Fig. 11-1z03
21		60904001	1"M NPT X 16M JIC 45 DEG ELBOW	3	
22		235714001	WASHER-FLATSTRL-.31-.34X.69-.06-YZ-A325	4	
23		238209001	BOLT-5/16-18X1 GR8 HEX ZINC YC	2	
24		240333001	NUT-5/16-18 GR8 TL ZINC PLTD	2	
25		485025	WASHER-1/2 FLAT-HARDENED-YZ	14	
26		240334001	SCREW-HCS-.50-13X1.75-GR8-YZ	10	
27		250512001	NUT- 1/2 NC Gr8 TOP LOCK Y/ ZINC	4	
28		235713001	WASHER-FLATSTRL-.38-.41X.81-.06-YA-A325	4	
29		235725001	NUT - HEX - .38 - 16 - GR8 - YZ	4	
30		296258568	FITTING - PLUG - 32MNPT - SQ - GALV	2	
31		296289008	FITTING - STR - 24MNPT - 32FNPT	1	
32		707007	*NIPPLE-3/4 HEX	1	
33		735001	3/4" COUNTERSUNK PIPE PLUG	1	
34		730017	1" X 3/4" HEX BUSHING STEEL	1	

Components-50 GPM FMC Fig 11-1z01





## Components-50 GPM FMC Fig 11-1z01

REF. NO.	*	PART NO.	DESCRIPTION	QTY.	REMARKS
1		278882002	PUMP CASE	1	
2		278882003	CRANK SHAFT	1	
3		278882004	BEARING HOUSING	1	
4		278882005	CONNECTING ROD	3	
5		278882006	BEARING HOUSING	1	
6		278882008	BEARING CONE	2	
7		278882009	BEARING CUP	2	
8			NAME PLATE	1	
9		248507009	SCREW - #4 X 3/16" LG SELF - TAPPING	2	
10		276521025	OIL CAP	1	
11		278882010	WRIST PIN	3	
12		278882012	SHIM	A/R	
13		278882013	GASKET COVER	1	
14		228460003	CAPSCREW-3/8-16X1 1/4 HEX HD	12	
15		278882015	SLEEVE	3	
16		278882016	SHELL BEARING (PAIR)	6	
17		278882017	SEAL	2	
18		278882018	ROD SEAL RETAINER	3	
19		904540035	OIL SEAL	6	
20		278882019	SET SCREW	6	
21		276521047	PLUG -1/2" PIPE, MAG	2	
22		278882020	WASHER PACKING	3	
23		278882021	CROSS HEAD ASSEMBLY	3	
24		278882022	CROSS OVER SUB	1	
25		904540049	WASHER-BARRIER	3	
26		278882037	BACK COVER	1	
27		278882007	O-RING - UNIFORM #160	2	
28		278882039	CAPSCREW - 3/8-16 X 3/4 LG HEX HEAD	16	
29		278882024	PISTON CUP	3	
30		225946033	VALVE ASSEMBLY-SUCTION	3	
31		225946025	VALVE ASSEMBLY-DISCHARGE	3	
32		278882027	SOCKET HEAD CAP SCREW	4	
33		278882036	EYE BOLT - 1/2 X 1-1/2	4	
34		240141005	FLUID CYLINDER	1	
35		225946017	PLUG-1 3/16-12 UN-2A	3	
36		225946011	PLUG-1 7/8-12 UN-2A	3	
37		278882028	PISTON CYLINDER	3	
38		240141009	SEAL HOLDER	3	
39		240141011	PISTON NUT	3	
40		228460023	HEX NUT-SPECIAL BRASS	2	
41		228460029	O-RING	3	
42		278882029	PISTON HOLDER	3	
43		228460027	CYLINDER COVER	3	
44		225946021	O-RING	3	
45		240141015	PISTON WASHER	3	
46		904540105	GASKET	6	
47		278882030	STUD	6	
48		278882031	FRONT FOOT	1	
49		904540059	CLAMP-COVER	3	
50		904540061	WASHER-5/8	10	
51		278882033	JAM NUT	2	
52		278882034	SOCKET HEAD CAP SCREW	2	
53		278882035	REAR FOOT	1	
54		904540063	NUT- 5/8-11	8	
55		904540057	STUD-SHORT	2	
56		278882032	LIQUID LEVEL GAUGE	1	
57		240141019	TOOL - PISTON CUP REMOVAL	1	
58		240141017	TOOL - VALVE INSTALLATION	1	
59		278882025	O-RING	1	
60		278882026	BEARING SLEEVE	1	
		278951001	PUMP - WATER		Includes All Items In Figure

Components-Pressure Dumbbell Piston Fig 11-1z02

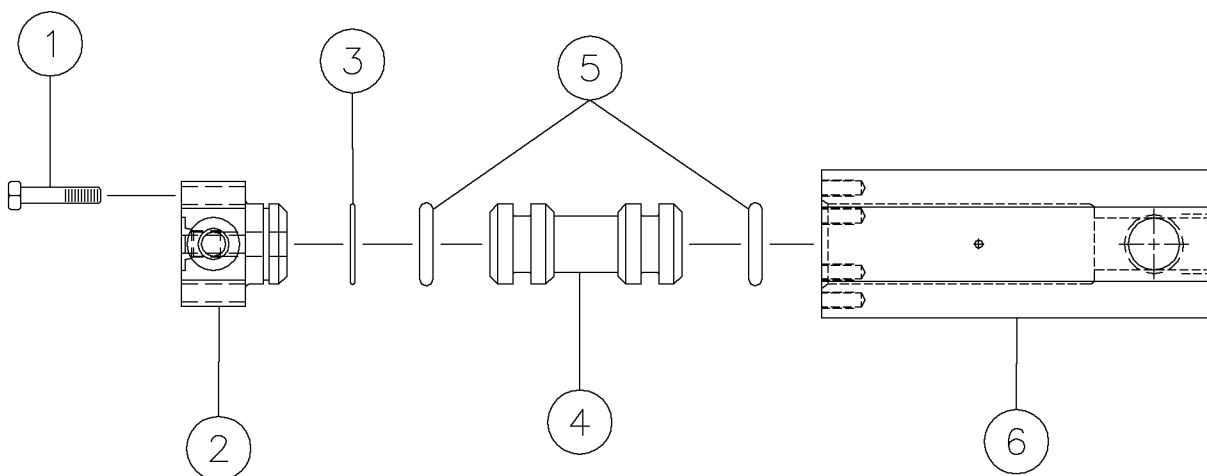

## Components-Pressure Dumbell Piston Fig 11-1z02

REF. NO.	*	PART NO.	DESCRIPTION	QTY.	REMARKS
1		250008001	BOLT 1/4-20 X 1 1/4 ZINC PL	6	
2		238138001	ENDCAP-MANIFOLD OUTLET FITTING	1	
3		234818001	O-RING 1.254OD X1.114ID-.070	1	
4		296265885	PISTON - INSERT MANIFOLD	1	
5		250612001	O-RING - 316	2	
6		296265884	FITTING - WATER MANIFOLD PRESSURE	1	
		296265854	WATER PRESSURE DUMBELL PISTON MAN.ASSY		Inc. All Items In Figure

Components-Ball Valve Fig 11-1z03

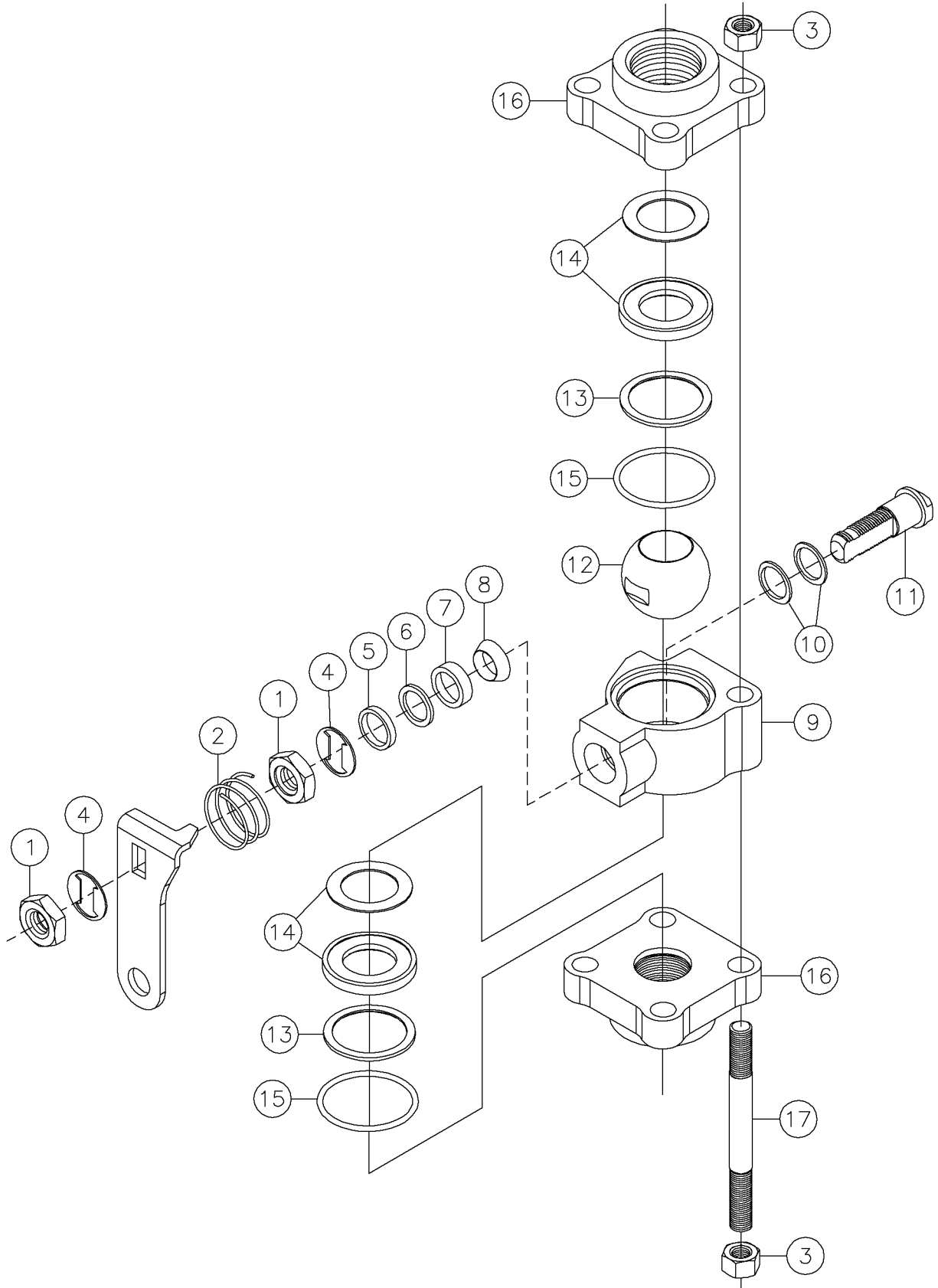

Components-Ball Valve Fig 11-1z03

REF. NO.	*	PART NO.	DESCRIPTION	QTY.	REMARKS
1		245079003	STEM NUT	2	
2		245079005	GROUNDING SPRING	1	
3		245079037	BODY NUT	8	
4		245079009	STEM SPRING	2	
5		278003003	GLAND	1	
6		245079013	PACKING SUPPORT	1	
7		245079015	TOP PACKING	1	
8		245079017	BOTTOM PACKING	1	
9		278003004	BODY CENTER	1	
10		278003005	BEARING - STEM	2	
11		245079023	STEM	1	
12		245079025	BALL	1	
13		245079027	SUPPORT RING	2	
14		245079029	SEAT/SEAT SPRING	2	
15		245079031	O-RING	2	
16		278003006	FLANGE	2	
17		245079035	BODY STUD	4	
		245079039	KIT-MAINTENANCE		Includes Ref. 4-6, 10 & 15
		278003001	VALVE - 1" 1500 PSI BRASS BALL		Includes All Items In Figure

Drive Motor-50 GPM FMC Fig 11-2

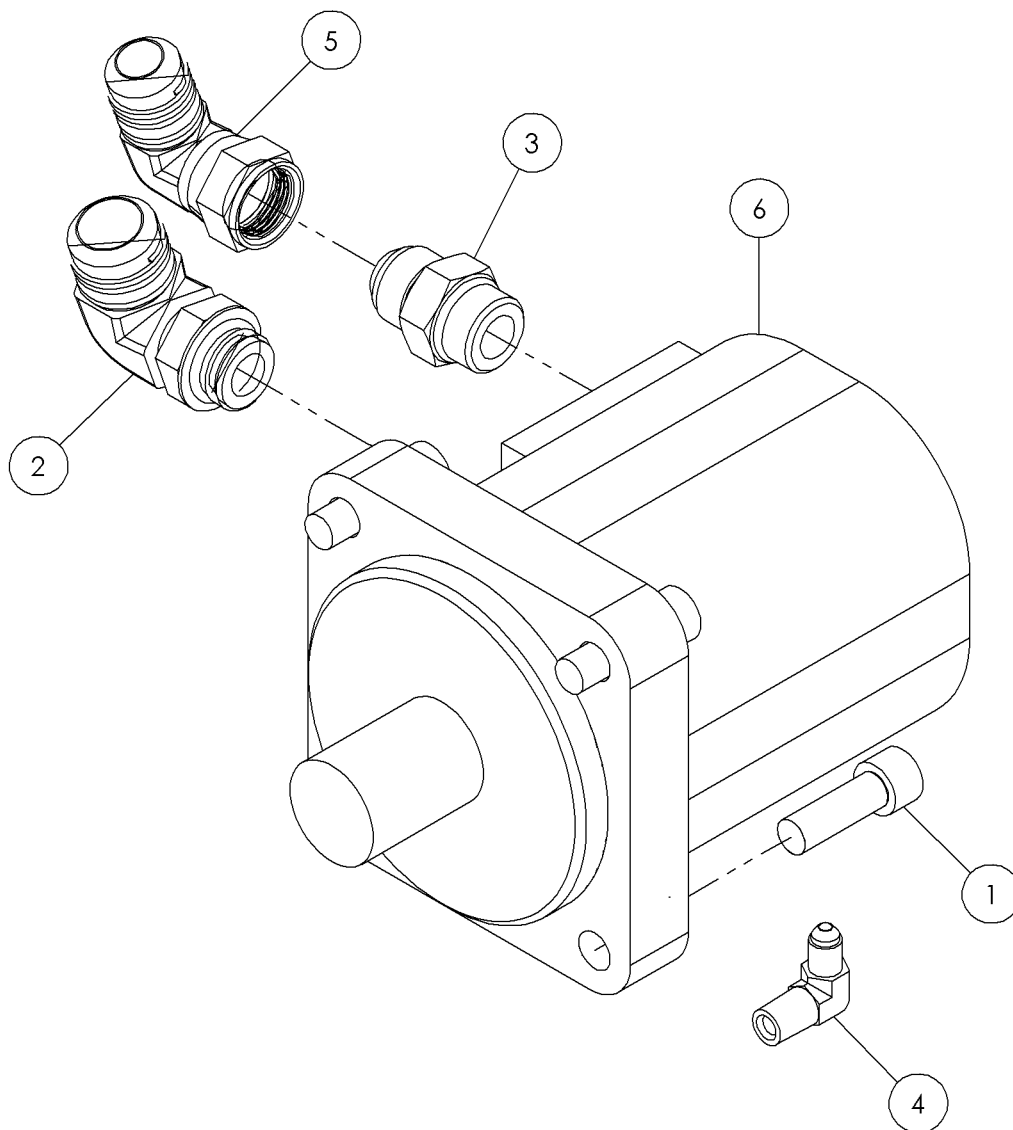
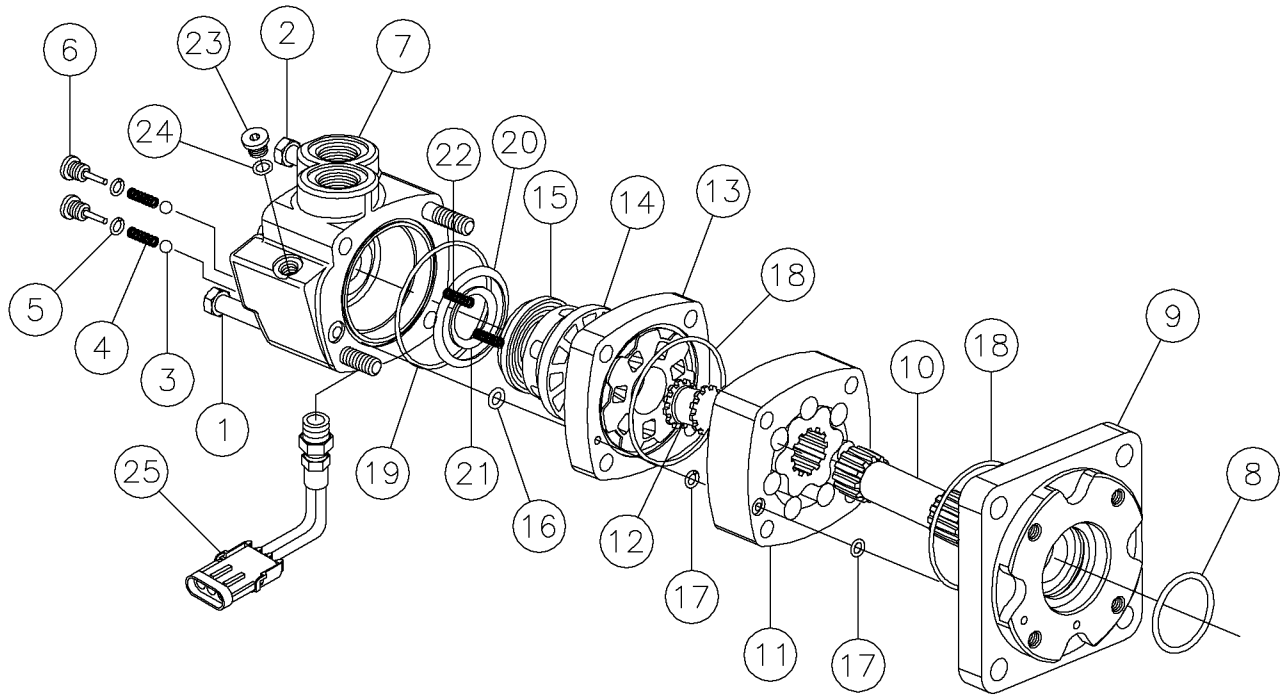

Illustration No. 296280900

## Drive Motor-50 GPM FMC Fig 11-2

REF. NO.	*	PART NO.	DESCRIPTION	QTY.	REMARKS
1		276402001	SCREW-1/2-13X1 1/2 SHC Y ZINC	4	
2		65571001	12M X 16M JIC 90 DEGREE	1	
3		53828001	#12M O-RING-#12M JIC ST.	1	
4		56647001	FITTING-1/4MX4M JIC 90 DEG.	1	
5		59422001	FITTING-90-12MJ-12FSJ	1	
6		251106001	MOTOR -12.5 CID 4000 SERIES HY	1	Breakdown Fig. 11-2z01

Components-Motor 50 GPM FMC Fig 11-2z01





## Components-Motor 50 GPM FMC Fig 11-2z01

REF. NO.	*	PART NO.	DESCRIPTION	QTY.	REMARKS
1		13514027	BOLT-14386-007	3	
2		13514025	BOLT-14386-009	1	
3		224408035	BALL	2	
4		224408037	SPRING	2	
5		4485011	O-RING-250003-903 (90D)	2	
6		224408039	PLUG/O-RING S/A	2	
7		251106007	HOUSING - VALVE	1	
8		215338003	SEAL	1	
9		251106003	FLANGE - MOUNTING	1	
10		217192005	DRIVE	1	
11			GEROLER	1	Not Sold Separately
12		600076019	VALVE	1	
13		600076017	PLATE - VALVE	1	
14		600076021	VALVE	1	
15		53853017	BALANCE RING&PINS 21316CHARLYN	1	
16		4485011	O-RING-250003-903 (90D)	2	
17		215338009	SEAL	2	
18		13514033	SEAL-3 1/2 ID	2	
19		775049	SEAL-9022-7	1	
20		775041	SEAL-OUTER FACE 6962	1	
21		775043	SEAL-FACE INNER 6961	1	
22		224408017	SPRING	2	
23		120872025	HEX PLUG	1	
24		1749025	SEAL-O RING 15007 (90D)	1	
25		251106009	SPEED PICKUP - ELECTRONIC	1	
		251106005	SEAL KIT		Includes Ref. 5, 16, 17, 19-21&24
		251106001	MOTOR -12.5 CID 4000 SERIES HY		Includes All Item In Figure

Water Pump-50 GPM APLEX Fig 11-3

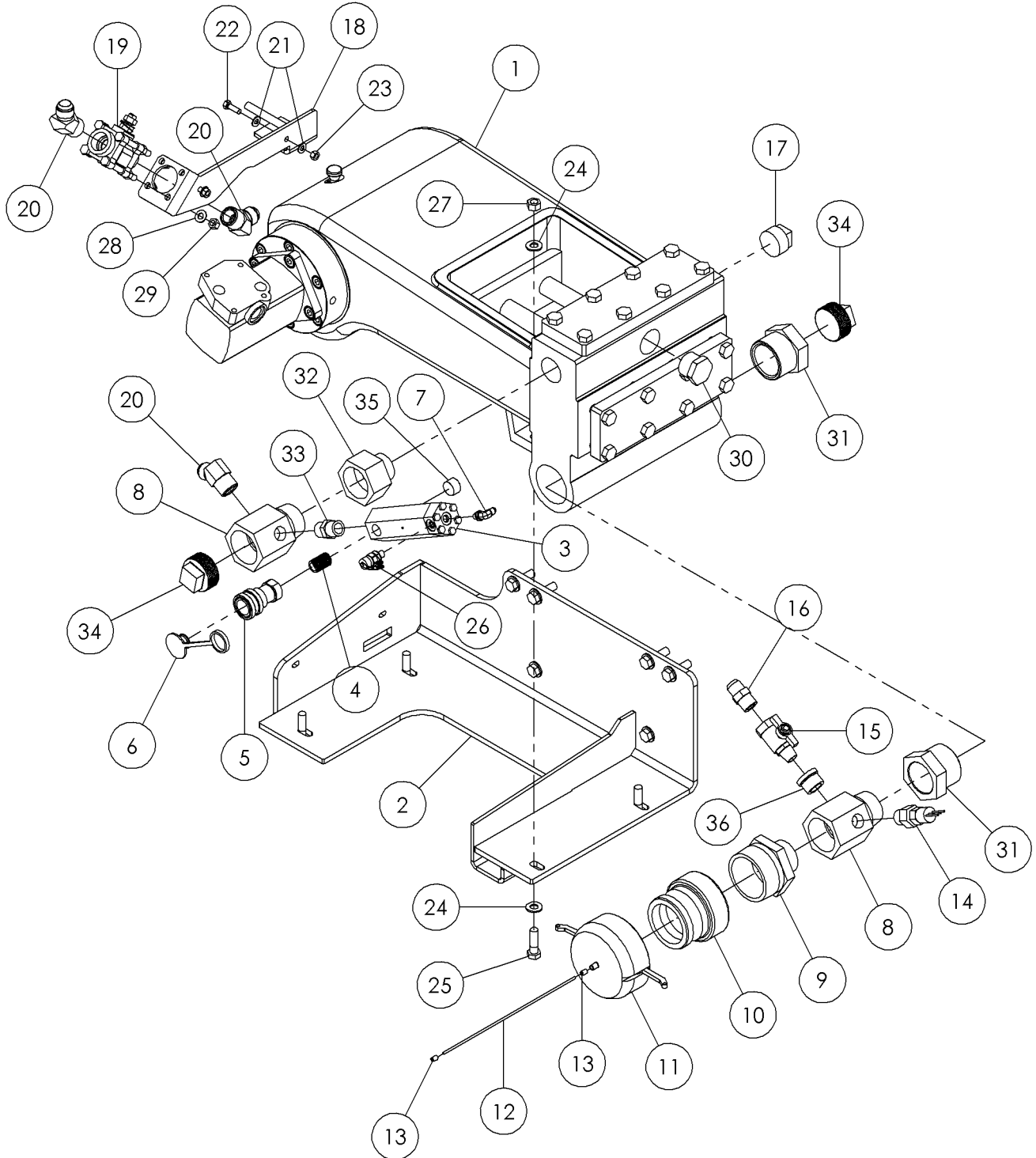
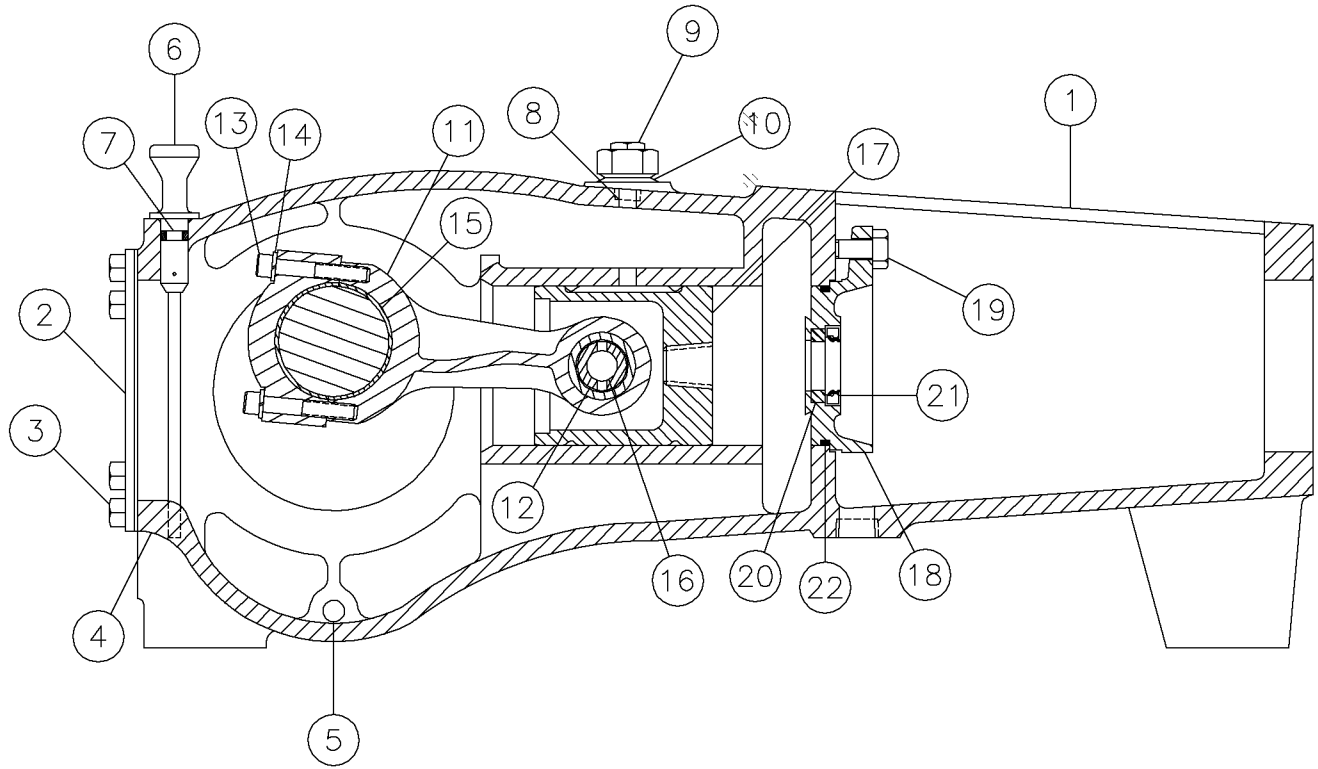

Illustration No. 296280892

## Water Pump-50 GPM APLEX Fig 11-3

REF. NO.	*	PART NO.	DESCRIPTION	QTY.	REMARKS
1		296269559	APLEX 50 GPM MUD PUMP W/CHARLYN HYD/DR M	1	Breakdown Fig. 11-3z01 Thru 11-3z05
2		296280862	PUMP SUPPORT ASY	1	
3		296265854	WATER PRESSURE DUMBELL PISTON MAN.ASSY	1	Breakdown Fig. 11-1z02
4		707003	1/2" NPT HEX NIPPLE	1	
5		227235001	COUPLER-1/2"NPT QUICK(FEMALE)	1	
6		234679001	CAP-DUST	1	
7		59423001	90-4MORBA-4MJ	1	
8		236472001	FITTING-2"MX3/4"FX2 XCX M NPT TEE	2	
9		221506001	NIPPLE-REDUCING 3X2 MPT (POLY)	1	
10		275759001	COUPLINE-3"MTPT X3" FPT (POLY)	1	
11		215429001	CAP-3" CAM LOCK	1	
12		244069001	CABLE-3/32"X12 XCX NYLON COATED	1	
13		1838001	CONNECTOR-WIRE (ETC)	2	
14		287554001	SWITCH - 10 PSI NO/NC	1	
15		275770001	VALVE - 3/4 MXF BALL W/T-HNDL	1	
16		53836001	3/4M PIPE-#12M JIC ST.	1	
17		732015	1 1/2" PIPE PLUG BLACK STEEL	1	
18		296303781	WATER VALVE SUPPORT	1	
19		278003001	VALVE - 1" 1500 PSI BRASS BALL	1	Breakdown Fig. 11-1z03
20		60904001	1"M NPT X 16M JIC 45 DEG ELBOW	3	
21		235714001	WASHER - FLATSTRL - .31 - .34 X .69 - .06-YZ-A325	4	
22		238209001	BOLT-5/16-18X1 GR8 HEX ZINC YC	2	
23		240333001	NUT-5/16-18 GR8 TL ZINC PLTD	2	
24		485025	WASHER-1/2 FLAT-HARDENED-YZ	14	
25		240334001	SCREW-HCS-.50-13X1.75-GR8-YZ	10	
26		75493001	FITTING - TEST - 4MORB - 16MTP	1	
27		250512001	NUT- 1/2 NC Gr8 TOP LOCK Y/ ZINC	4	
28		235713001	WASHER - FLATSTRL - .38 - .41 X .81 - .06-YA-A325	4	
29		235725001	NUT - HEX - .38 - 16 - GR8 - YZ	4	
30		120885001	FITTING-1 1/4 NPT PIPE PLUG	1	
31		236015001	HEX BUSHING-40MPT X 32FPT	2	
32		296289008	FITTING - STR - 24MNPT - 32FNPT	1	
33		707007	NIPPLE-3/4 HEX	1	
34		296258568	FITTING - PLUG - 32MNPT - SQ - GALV	2	
35		735001	3/4" COUNTERSUNK PIPE PLUG	1	
36		730017	1" X 3/4" HEX BUSHING STEEL	1	

Components-Crankshaft Fig 11-3z01



Components-Crankshaft Fig 11-3z01

REF. NO.	*	PART NO.	DESCRIPTION	QTY.	REMARKS
1		296272942	POWER FRAME	1	
2		220741007	CRANKCASE COVER	1	
3		220741009	3/8-16X5/8 HHCS	8	
4		220741011	GASKET-CRANKCASE COVER	1	
5		296272943	PIPE PLUG 3/8" SQUARE HEAD	2	
6		220741021	OIL LEVEL DIPSTICK	1	
7		220741023	O-RING 2-023	1	
8		296272944	PIPE PLUG 1/8" SOCKET HEAD	3	
9		277781019	FILTER - BREATHER	1	
10		220741017	1/2" NPT PLUG-SOCKET HEAD	1	
11		220741025	CONNECTING ROD	3	Inc. Ref. No's 12, 13, & 14
12		296272945	BUSHING-WRIST PIN	1	
13		220741029	5/16-18X2" SOCKET HD CAP SCREW	2	
14		220741031	5/16" LOCKWASHER	2	
15		220741033	CRANK PIN BEARING HALF	3	
16		220741035	WRIST PIN	3	
17		220741037	CROSSHEAD	3	
18		220741039	WIPER BOX	3	
19		296272946	SCREW-3/8"X1 1/4" HEX HEAD	6	
20		220741045	POLYPAK RING	3	
21		220741047	OIL SEAL	3	
22		220741049	O-RING	3	
		296269559	APLEX 50 GPM MUD PUMP W/CHARLYN HYD/DR M		(Inc. All Items in Figure.)

Components-Power Frame Fig 11-3z02

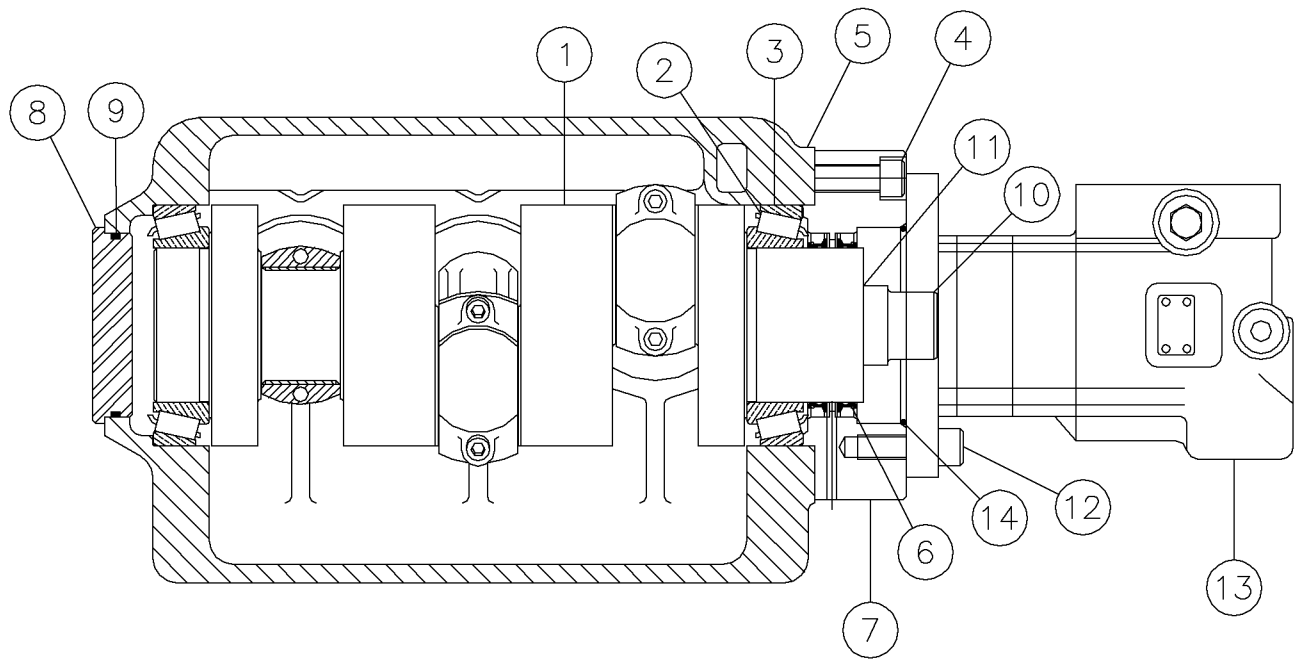

## Components-Power Frame Fig 11-3z02

REF. NO.	*	PART NO.	DESCRIPTION	QTY.	REMARKS
1		228098011	CRANKSHAFT	1	
2		228098013	CONE	2	
3		228098015	CUP	2	
4		296272949	SCREW -1/2"NC X 2" LONG HEX HEAD CAP	6	
5		220741113	SHIM SET	1	
6		228098025	OIL SEAL	2	
7		228098019	BEARING RETAINER/MOTOR ADAPTER	1	
8		277781025	PLUG - CRANK SHAFT	1	
9		220741121	O-RING	1	
10		228098027	SPLINED COUPLER -SC45 PUMP	1	
11		224904009	SPACER-HARDENED SPLINE ADAPTER	1	
12		239383023	CAP SCREW-1/2 NC-1 1/4 HEX HD	4	
13		275996001	MOTOR - HYD. (EATON) 2 SP.	1	
14		220741125	O-RING NITRILE	1	
		296269559	APLEX 50 GPM MUD PUMP W/CHARLYN HYD/DR M		Includes All Items in Figure

Components-Fluid End Fig 11-3z03

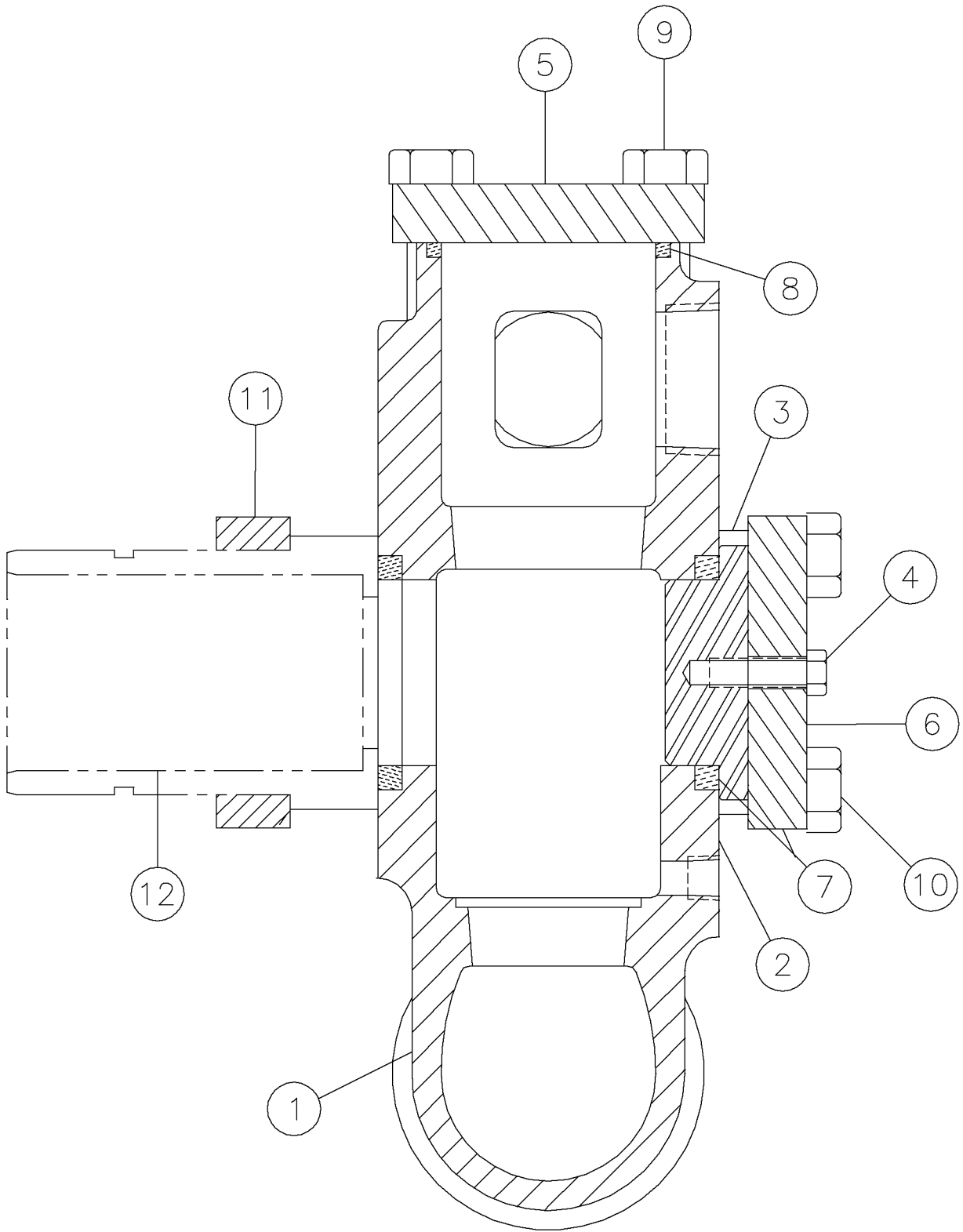



## Components-Fluid End Fig 11-3z03

REF. NO.	*	PART NO.	DESCRIPTION	QTY.	REMARKS
1		296272950	FLUID END	1	
2		296272951	SCREW-3/4"NC X 4 1/2" SOCKET HEAD CAP	2	
3		224408109	VALVE COVER AND CYL.HEAD PLUG	3	
4		220741057	3/8-16X1 1/4" HHCS	3	
5		296272952	VALVE COVER	1	
6		220741059	RETAINER PLATE	2	
7		224408131	SEAL-STUFFING BOX (RUBBER)	3	
8		296272953	O-RING #335	3	
9		277780030	HEX HD CAP SCREW - 5/8 NCX 1 3/4	8	
10		220741065	5/8-11X7 1/2" HHCS	8	
11		296272954	RETAINER PLATE	1	
12		220741069	3/8-16 X 1 1/2" HHCS	2	

Components-Suction/Discharge Valve Fig 11-3z04

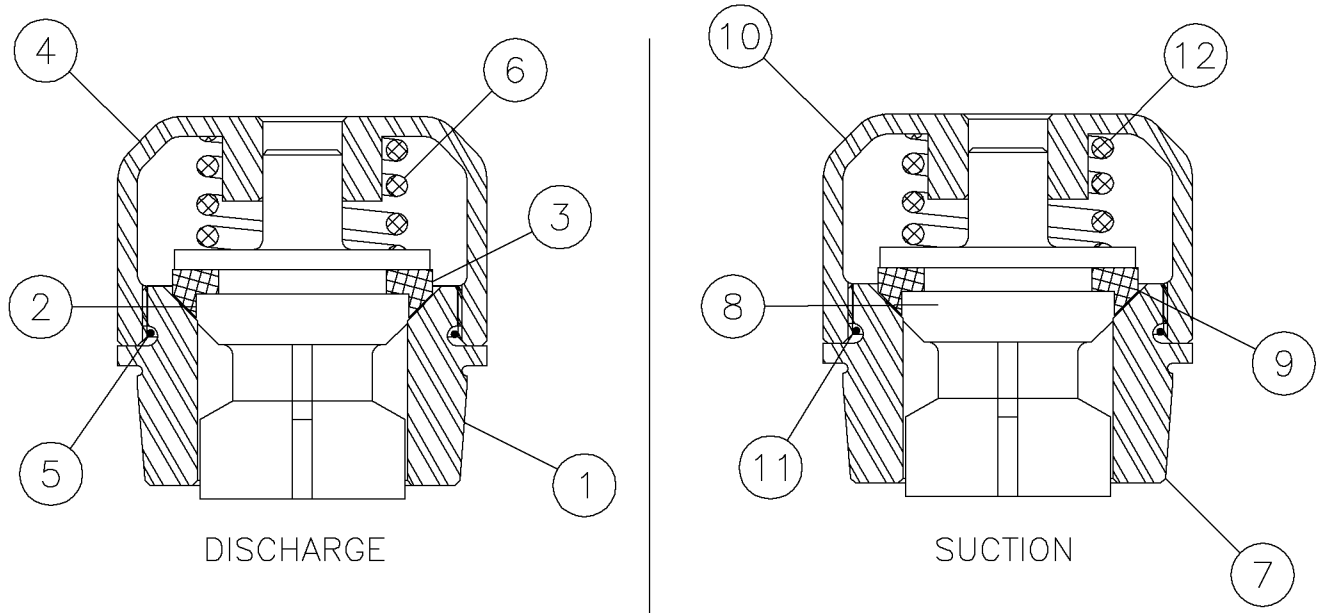

ABRASIVE RESISTANT VALVES

## Components-Suction/Discharge Valve Fig 11-3z04

REF. NO.	*	PART NO.	DESCRIPTION	QTY.	REMARKS
1		244460021	VALVE SEAT - DISCHARGE	1	
2		244460029	VAVLE BODY	1	
3		244460023	POLYURETHANE INSERT	1	
4		244460027	GUIDE CAGE	1	
5		224408125	O-RING (RUBBER) SIZE 032	1	
6		220741141	SPRING - VALVE	1	
7		244460033	VALVE SEAT - SUCTION	1	
8		244460029	VAVLE BODY	1	
9		244460023	POLYURETHANE INSERT	1	
10		244460027	GUIDE CAGE	1	
11		224408125	O-RING (RUBBER) SIZE 032	1	
12		220741141	SPRING - VALVE	1	
		244460005	VALVE ASSY - ABRASIVE RESISTANT ( SUCTION)	3	Inc. Ref. No's 7-12
		244460007	VALVE ASSY - ABRASIVE RESISTANT (DISCHARGE)	3	Inc. Ref. No's 1-6

Components-Piston Fig 11-3z05

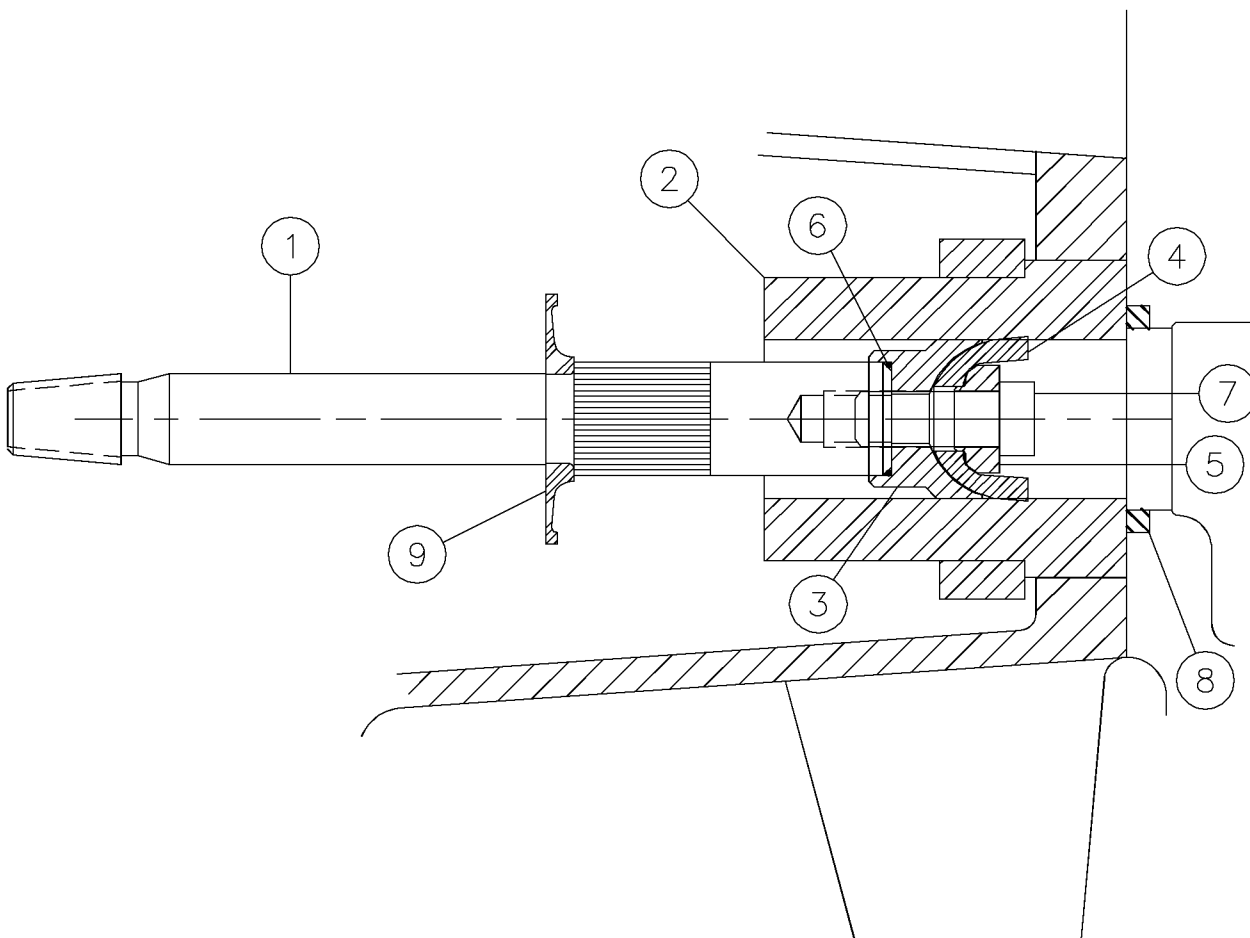

## Components-Piston Fig 11-3z05

REF. NO.	*	PART NO.	DESCRIPTION	QTY.	REMARKS
1		296272955	PISTON ROD	1	
2		296272956	PISTON LINER-2 1/4" WHITE CERAMIC	1	
3		296272957	PISTON HUB	1	
4		296272958	PISTON CUP HSN & KEVLAR	1	
5		296272959	PISTON KEEPER	1	
6		220741075	O-RING-POLYURETHANE (SIZE 024)	1	
7		279264001	PISTON - FASTENER END	1	
8		224408131	SEAL-STUFFING BOX (RUBBER)	1	
9		220741091	BAFFLE PLATE-LOW TEMP. RUBBER	1	

Drive Motor-50 GPM APLEX Fig 11-4

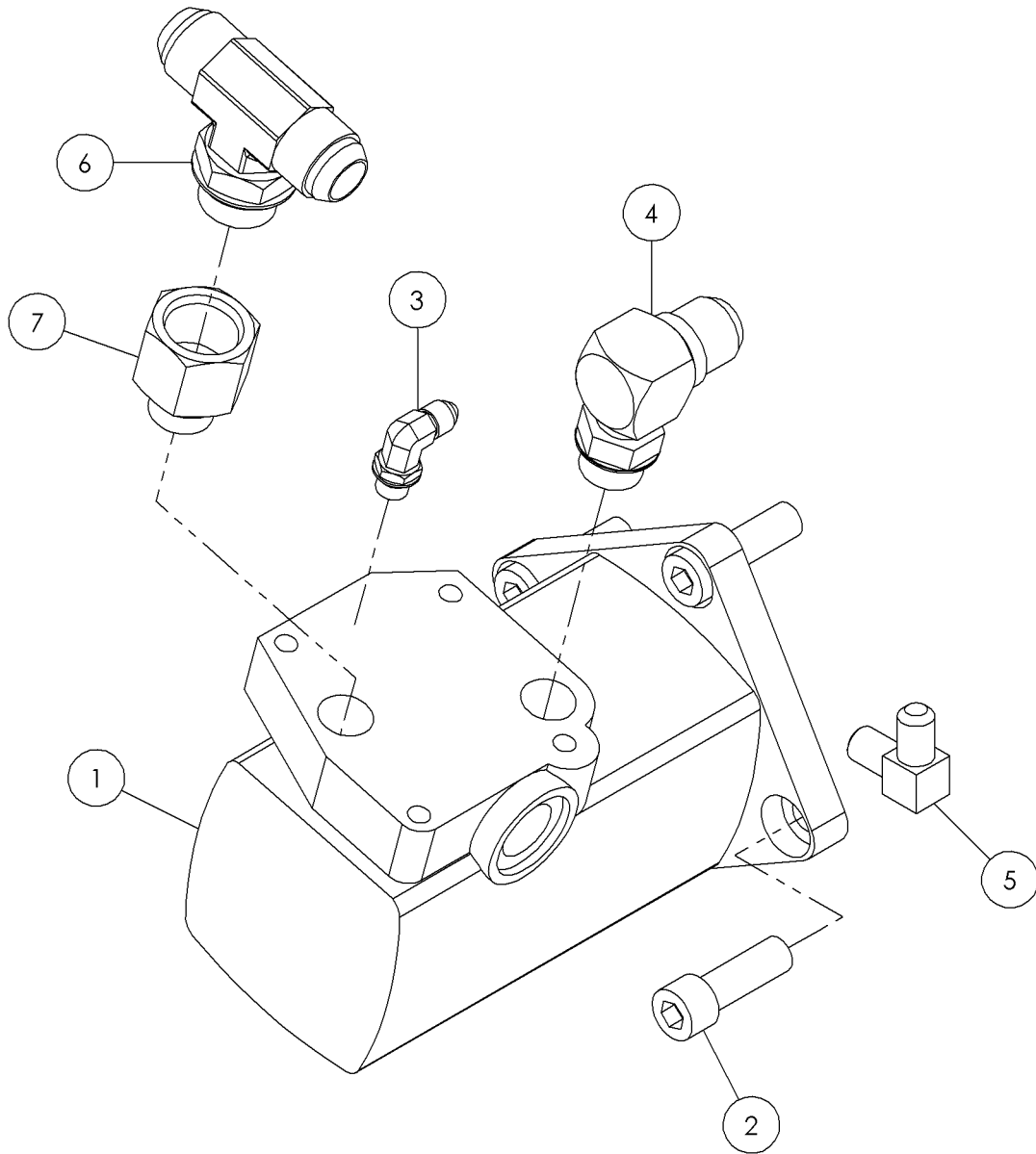
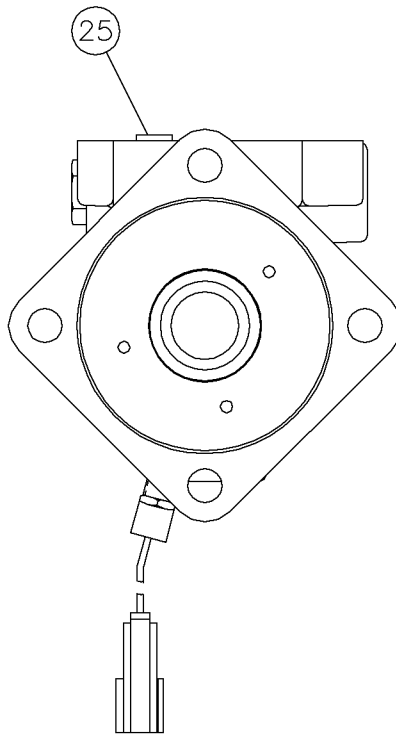
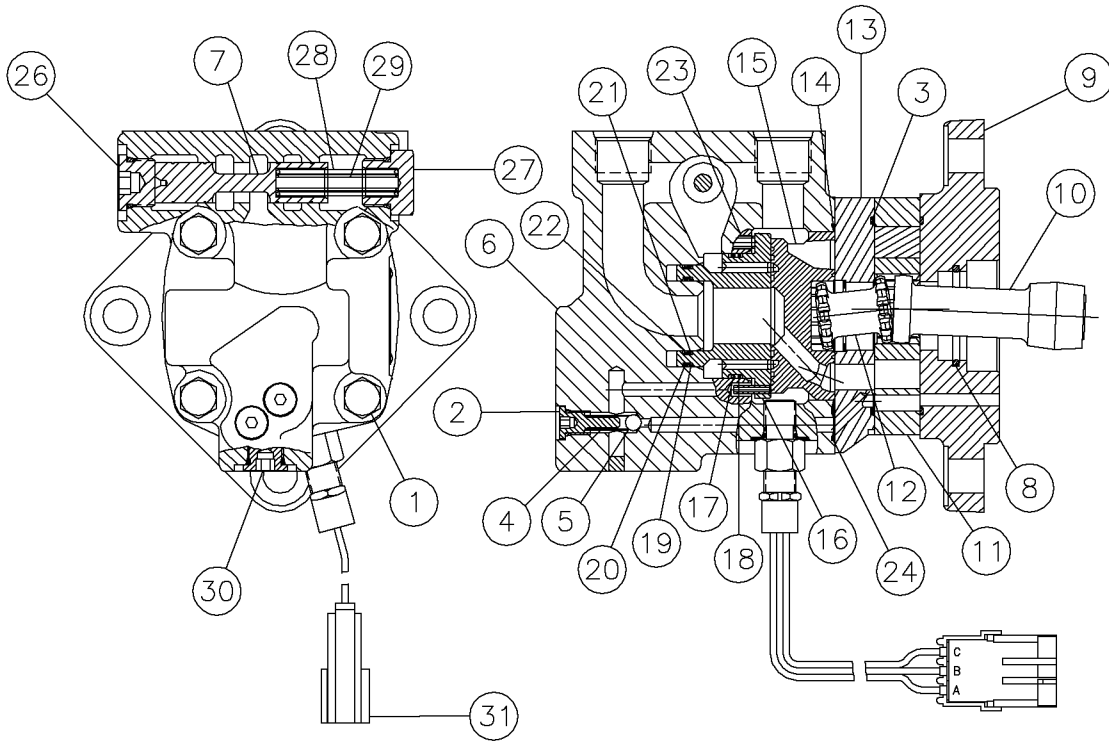

Illustration No. 296279916

## Drive Motor-50 GPM APLEX Fig 11-4

REF. NO.	*	PART NO.	DESCRIPTION	QTY.	REMARKS
1		275996001	MOTOR - HYD. (EATON) 2 SP.	1	Breakdown Fig. 11-4z01
2		514014	1/2-13X1 1/2" SOCKET HEAD BOLT	4	
3		59423001	FIT-4M JICX4M ADJ.90 DEG.ELBOW	1	
4		53871001	#10M O-RING X 12M JIC 90	1	
5		68707001	FITTING-1/4MX6M JIC 90 DEG.	1	
6		70032001	12M BCH X 12M JICX12M JIC TEE	1	
7		119167001	FITTING-10M X 12F ST. ADAPTER	1	

Components-Motor 50 GPM APLEX Fig 11-4z01





## Components-Motor 50 GPM APLEX Fig 11-4z01

REF. NO.	*	PART NO.	DESCRIPTION	QTY.	REMARKS
1		771017	BOLT	4	
2		4485015	CHECKING PLUG ASSY.	2	
3		4485011	O-RING-250003-903 (90D)	2	
4		770007	SEAL-O RING 9022-6	2	
5		770051	SPRING	2	
6		275996003	HOUSING	1	
7		201666043	SPOOL-CONTROL	1	
8		221557007	SEAL-O-RING	1	
9		221557009	FLANGE-MOUNTING (BEARING LESS)	1	
10		770081	DRIVE	1	
11			GEROLER ASSY.	1	Not Sold Separately
12		774011	DRIVE-VALVE	1	
13		275996002	PLATE - VALVE	1	
14		201666009	SEAL	1	
15		220749003	VALVE	1	
16		201666013	RING ASSY.-BALANCING	1	
		201666015	PIN-SPRING	2	
17		201666023	O-RING	1	
18		201666021	RING-BACKUP	2	
19		201666025	O-RING	1	
20		201666027	RING-BACKUP	1	
21		201666017	O-RING	1	
22		201666019	RING-BACKUP	1	
23		770039	SPRING	1	
24		1749025	SEAL-O-RING	1	
25		4485021	PLUG ASSY.	1	
		4485023	O-RING	1	
26		66845001	PLUG ASSY.	1	
		4343031	O-RING	1	
27		201666035	PLUG-ASSY.	1	
		4343031	O-RING	1	
28		201666041	SPRING-COMPRESSION	1	
29		201666039	SPRING-COMPRESSION	1	
30		500659021	SAE PLUG	1	
31		251106009	SPEED PICKUP - ELECTRONIC	1	
		275996001	MOTOR - HYD. (EATON) 2 SP.		Includes Ref No's 1-29
		221557003	REPAIR KIT		Includes Ref No's 3, 8, 14, 17-22&25-27

Water Pump-70 GPM APLEX Fig 11-5

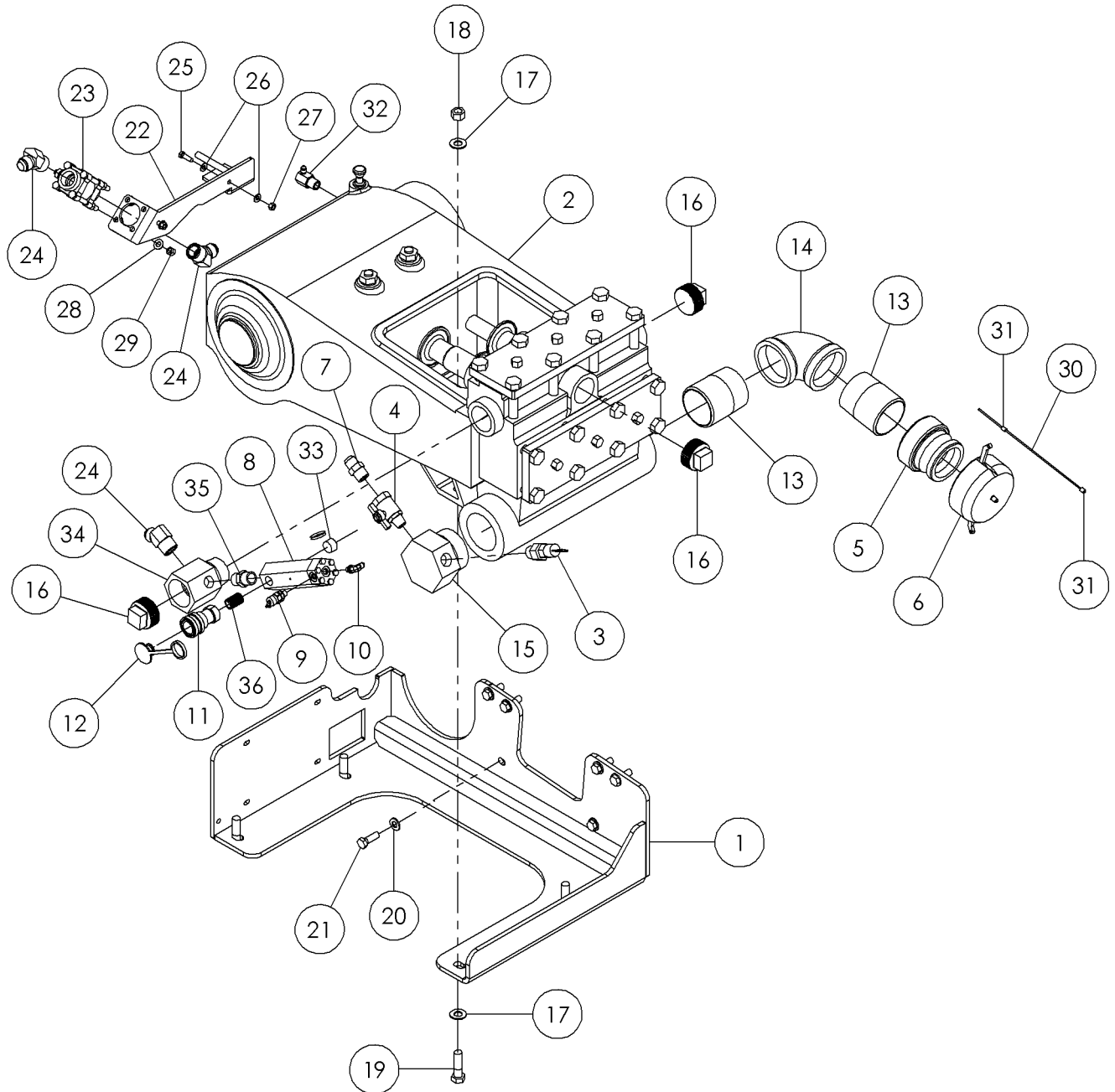
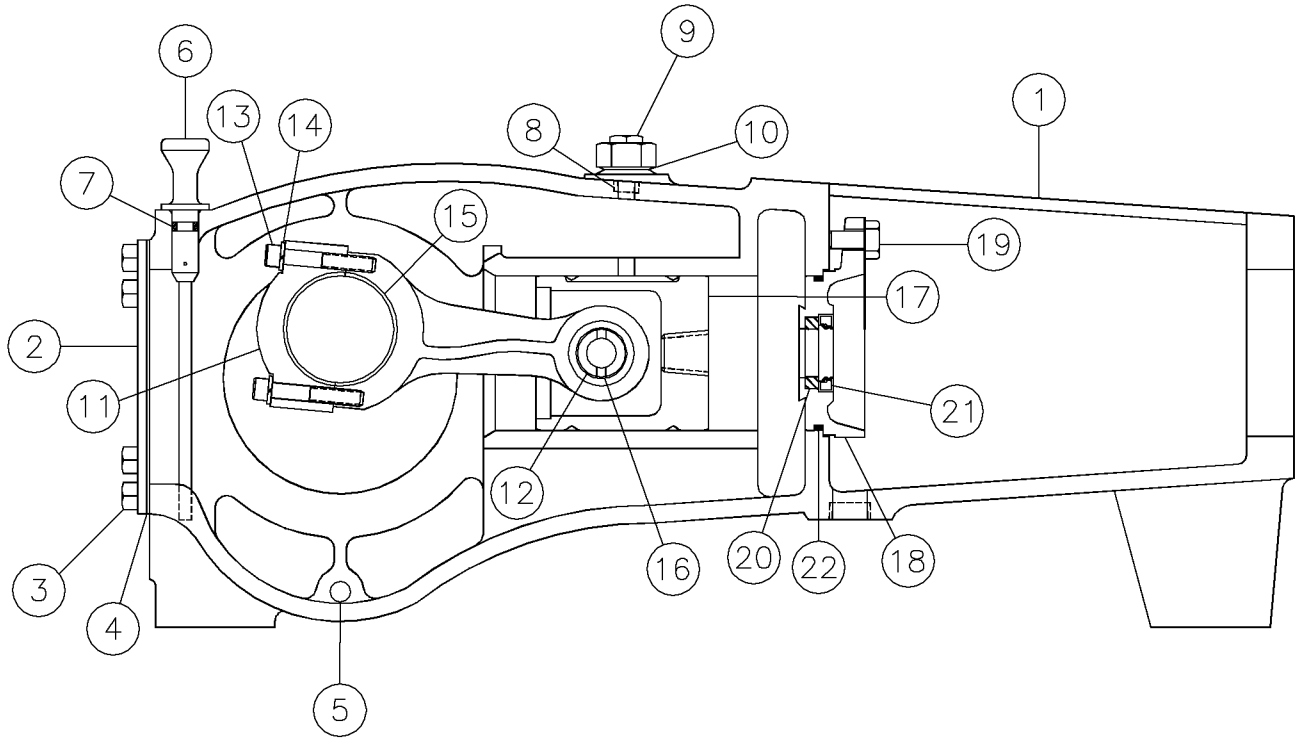

Illustration No. 296279882

## Water Pump-70 GPM APLEX Fig 11-5

REF. NO.	*	PART NO.	DESCRIPTION	QTY.	REMARKS
1		296279880	PUMP SUPPORT	1	
2		296279957	PUMP-MUD - 70 GPM	1	Breakdown Fig. 11-5z01 Thru 11-5z05
3		287554001	SWITCH - 10 PSI NO/NC	1	
4		275770001	VALVE - 3/4 MXF BALL W/T-HNDL	1	
5		275759001	COUPLINE-3"MTPT X3" FPT (POLY)	1	
6		215429001	CAP-3" CAM LOCK	1	
7		53836001	3/4M PIPE-#12M JIC ST.	1	
8		296265854	WATER PRESSURE DUMBELL PISTON MAN.ASSY	1	Breakdown Fig. 11-5z01 Thru 11-1z02
9		75493001	FITTING - TEST - 4MORB - 16MTP	1	
10		59423001	90-4MORBA-4MJ	1	
11		227235001	COUPLER-1/2"NPT QUICK(FEMALE)	1	
12		234679001	CAP-DUST	1	
13		296280248	FITTING-3" X CL GALV NIPPLE	2	
14		296280200	FITTING-3"FNPT-3"FNPT-90 DEG. GAL.	1	
15		296280201	FITTING - REDUCER 90, 3" MNPT 3/4 FNPT H	1	
16		296258568	FITTING - PLUG - 32MNPT - SQ - GALV	3	
17		235715001	WASHER-FLATSTRL-5/8" YZ A325	8	
18		250526001	NUT - 5/8-18 NF HEX Y/ZINC	4	
19		238245001	BOLT 5/8" - 11 X 2 1/4 Gr 8 HEX	4	
20		235712001	WASHER-1/2 SAE HARD ZINC PLTD	6	
21		235721001	BOLT-1/2-13X1 1/2 GR8 ZINC PLT	6	
22		296303781	WATER VALVE SUPPORT	1	
23		278003001	VALVE - 1" 1500 PSI BRASS BALL	1	Breakdown Fig. 11-1z03
24		60904001	1"M NPT X 16M JIC 45 DEG ELBOW	3	
25		238209001	BOLT-5/16-18X1 GR8 HEX ZINC YC	2	
26		235714001	WASHER-FLATSTRL-.31-.34X.69-.06-YZ-A325	4	
27		240333001	NUT-5/16-18 GR8 TL ZINC PLTD	2	
28		235713001	WASHER-FLATSTRL-.38-.41X.81-.06-YA-A325	4	
29		235725001	NUT - HEX - .38 - 16 - GR8 - YZ	4	
30		244069001	CABLE-3/32"X12 XCX NYLON COATED	1	
31		1838001	CONNECTOR-WIRE (ETC)	2	
32		54386001	1/2M PIPEX#4M JIC 90 DEG EL	1	
33		735001	3/4" COUNTERSUNK PIPE PLUG	1	
34		236472001	FITTING-2"MX3/4"FX2 XCX FNPT TEE	1	
35		707007	*NIPPLE-3/4 HEX	1	
36		707003	1/2" NPT HEX NIPPLE	1	

Components-Crankshaft Fig 11-5z01



## Components-Crankshaft Fig 11-5z01

REF. NO.	*	PART NO.	DESCRIPTION	QTY.	REMARKS
1		296285084	POWER FRAME KIT	1	
2		296285085	CRANKCASE	1	
3		220741009	3/8-16X5/8 HHCS	8	
4		224408079	GASKET-CRANKCASE COVER	1	
5		239383013	PLUG-3/8 PIPE SQ HEAD STEEL	2	
6		224408081	OIL LEVEL DIPSTICK	1	
7		224408083	O-RING	1	
8		239383009	PLUG-1/4 NPT SOCKET HEAD PLUG	3	
9		277781019	FILTER - BREATHER	1	
10		296285086	3/4" PIPE PLUG	1	
11		224408085	CONNECTING ROD	3	
12		224408087	WRIST PIN BUSHING	1	
13		296285087	3/8" NCX2 1/2" LONG SOCKET HEAD	2	
14		296285088	3/8" REG SPRING LOCKWASHER	2	
15		283701001	BEARING - CRANK PIN 2 HALVES SC65	3	
16		224408091	WRIST PIN	3	
17		224408093	CROSSHEAD	3	
18		224408095	WIPER BOX	3	
19		296285089	1/2'X1 1/2" LONG HEX HEAD	6	
20		224408099	POLYPAK RING	3	
21		224408101	OIL SEAL-WIPER BOX	3	
22		224408103	O-RING-WIPER BOX	3	

Components-Power Frame Fig 11-5z02

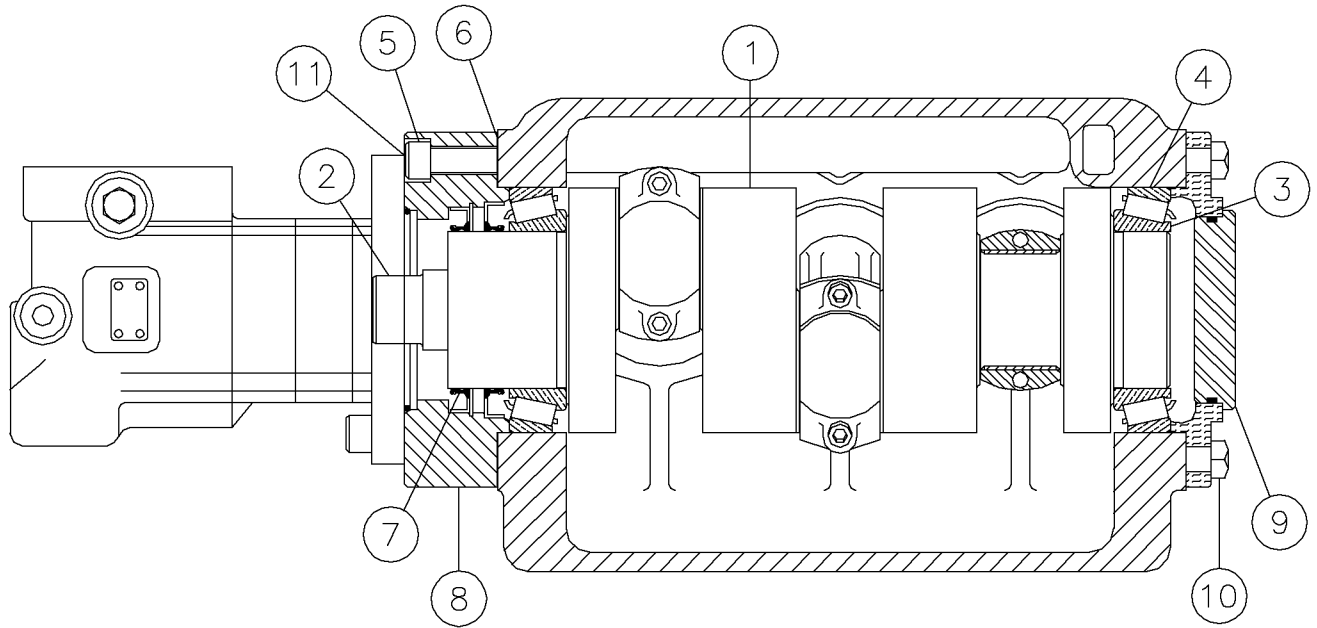

## Components-Power Frame Fig 11-5z02

REF. NO.	*	PART NO.	DESCRIPTION	QTY.	REMARKS
1		244460009	CRANKSHAFT	1	
2		244460011	SPLINE ADAPTER	1	
3		234309005	BEARING CONE	2	
4		296285091	BEARING CUP	2	
5		296285092	1/2" NC HEX HEAD CAP SCREW 2 3/4" LONG	6	
6		277781013	SHIM SET	1	
7		228098025	OIL SEAL	1	
8		244460015	BEARING RETAINER & MOTOR ADAPTER	1	
9		296285093	BLIND BEARING RETAINER	1	
10		296285089	1/2"-13UNC HEX HD. CAP SCREW X 1 1/2" LONG	6	
11		296302412	GASKET	1	
		296285090	CRANKSHAFT ASSY		Inc. Ref. 1 And 2
		296253158	SC - 65 LH - CRANKSHAFT KIT W/ BEARINGS		Inc. Ref. 1-4

Components-Fluid End Fig 11-5z03

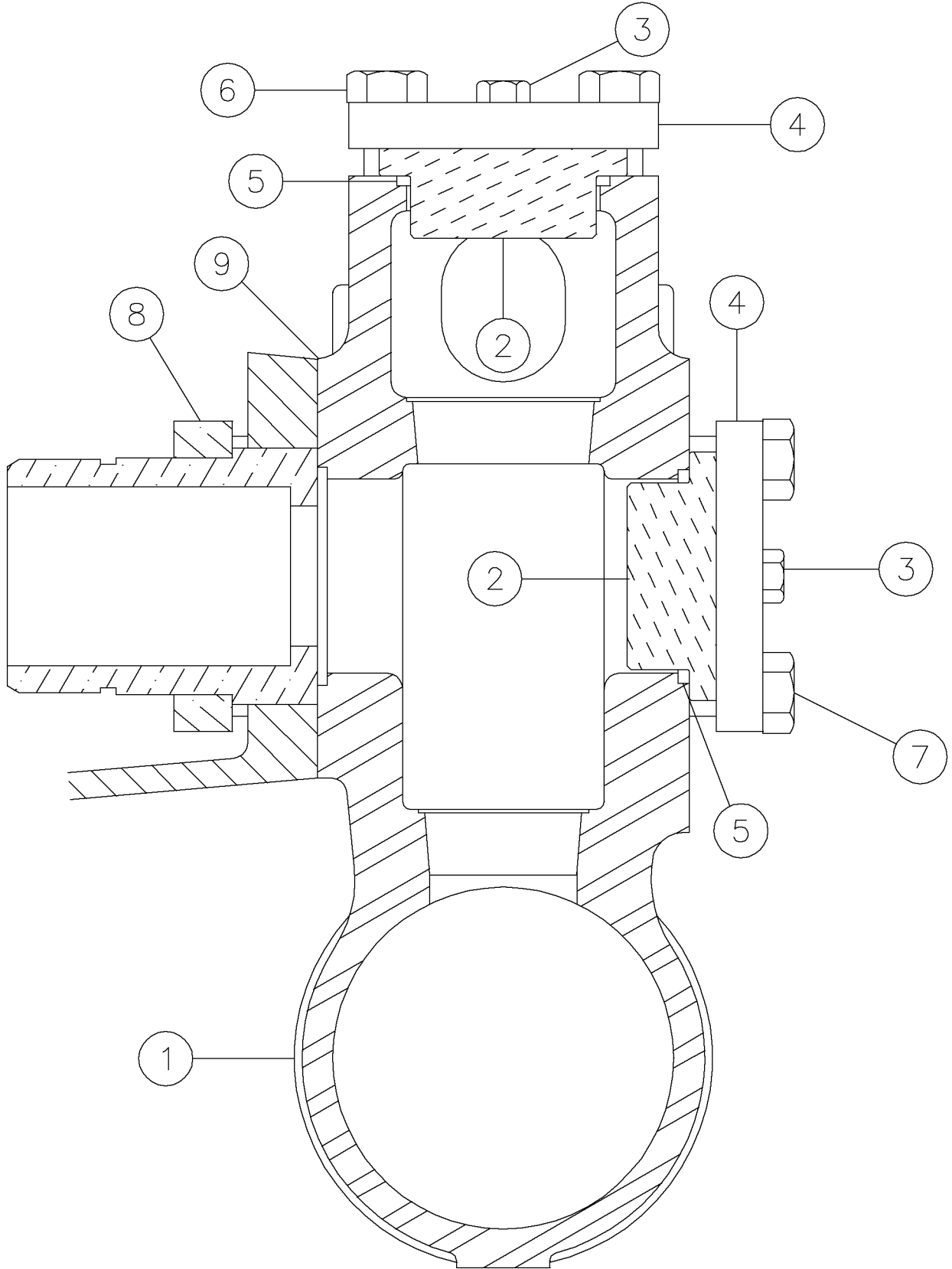



## Components-Fluid End Fig 11-5z03

REF. NO.	*	PART NO.	DESCRIPTION	QTY.	REMARKS
1		296285095	FLUID END-DUCTILE IRON	1	Includes All Items In Figure
2		244643021	VALVE COVER & CYL. HEAD PLUG	6	
3		239383023	CAP SCREW-1/2 NC-1 1/4 HEX HD	6	
4		244460017	VALVE COVER & CYL HEAD PLUG RETAINER	2	
5		296251335	O-RING - FLUID SEAL	6	
6		244643023	SCREW-3/4-10 X 2 1/2 HEX HD C	8	
7		244643025	SCREW-3/4-10 X 9 1/2 HEX HD C	8	
8		296285096	RETAINER PLATE	1	
9		277781035	HEX HD CAP SCREW - 5/8 X 2 1/4	2	

Components-Suction/Discharge Valve Fig 11-5z04

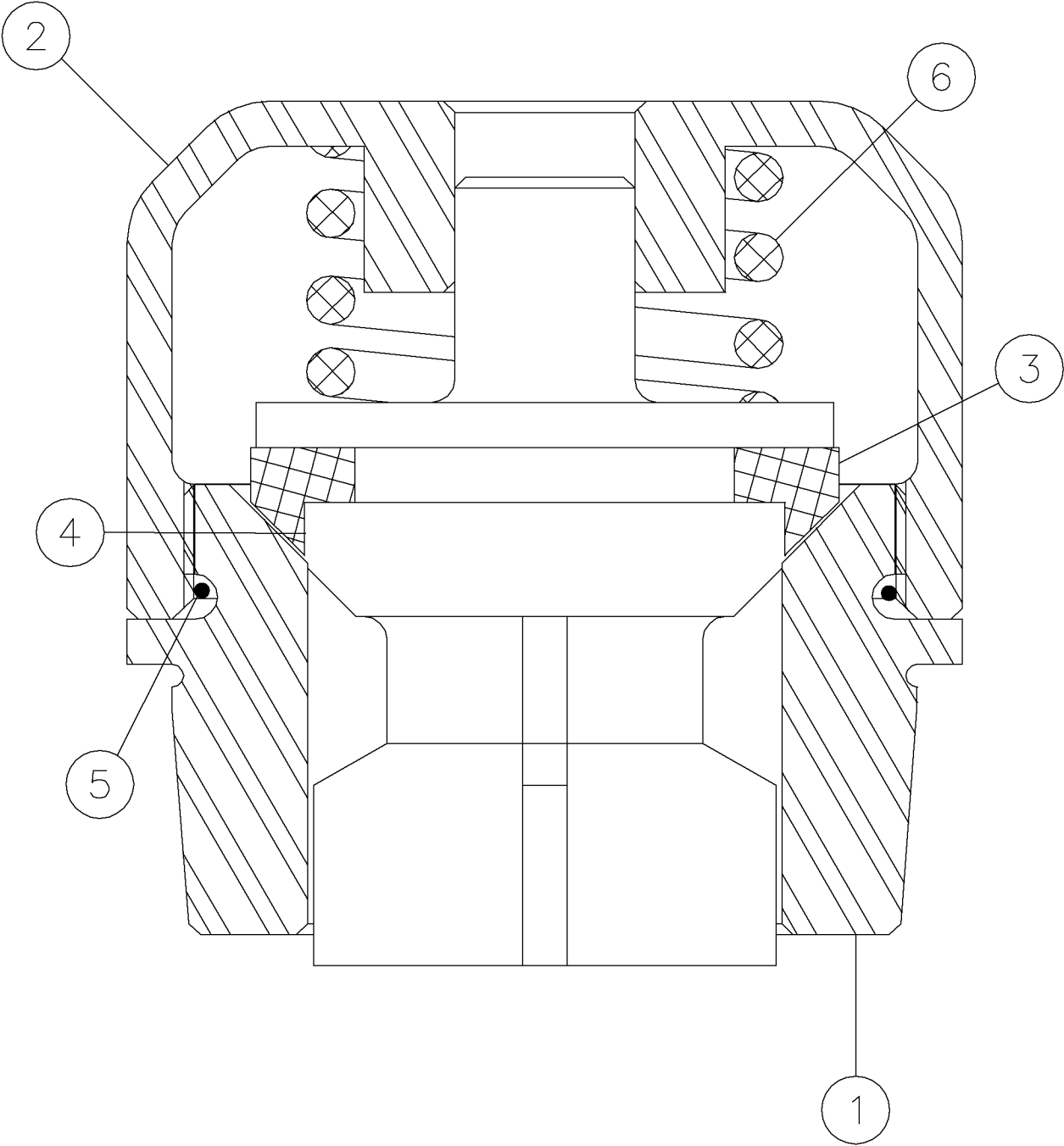

## Components-Suction/Discharge Valve Fig 11-5z04

REF. NO.	*	PART NO.	DESCRIPTION	QTY.	REMARKS
1		277781043	VALVE SEAT - SUCTION	1	
2		277781045	VALVE BODY	1	
3		277781047	POLYURETHANE THRUST	1	
4		277781049	GUIDE CAGE	1	
5		239383033	O-RING NITRILE RUBBER-2-035	1	
6		277781053	VALVE SPRING	1	
		277781057	VALVE ASSEMBLY - SUCTION	3	Inc. Ref. 1-6
		277781059	VALVE ASSEMBLY - DISCHARGE	3	Inc. Ref. 1-6

Components-Piston Fig 11-5z05

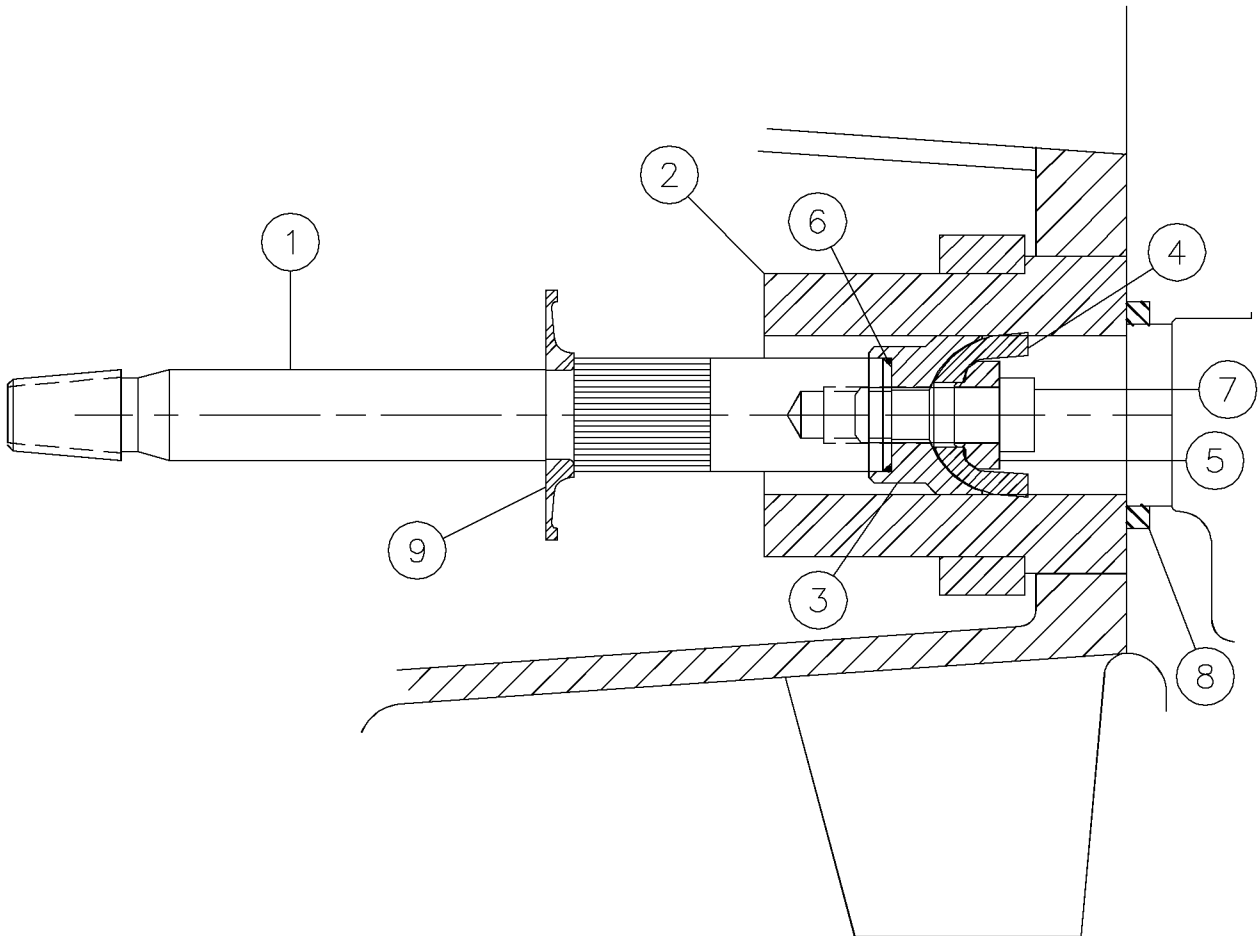

## Components-Piston Fig 11-5z05

REF. NO.	*	PART NO.	DESCRIPTION	QTY.	REMARKS
1		279254001	PISTON - ROD	1	
2		296251337	PISTON LINER 3"	1	
3		296285098	PISTON HUB	1	
4		296285099	PISTON CUP HSN & KEVLAR	1	
5		296285100	PISTON KEEPER	1	
6		220741075	O-RING-POLYURETHANE (SIZE 024)	1	
7		279264001	PISTON - FASTENER END	1	
8		296251341	FLUID SEAL	1	
9		277781061	BAFFLE PLATE	1	

Drive Motor-70 GPM APLEX Fig 11-6

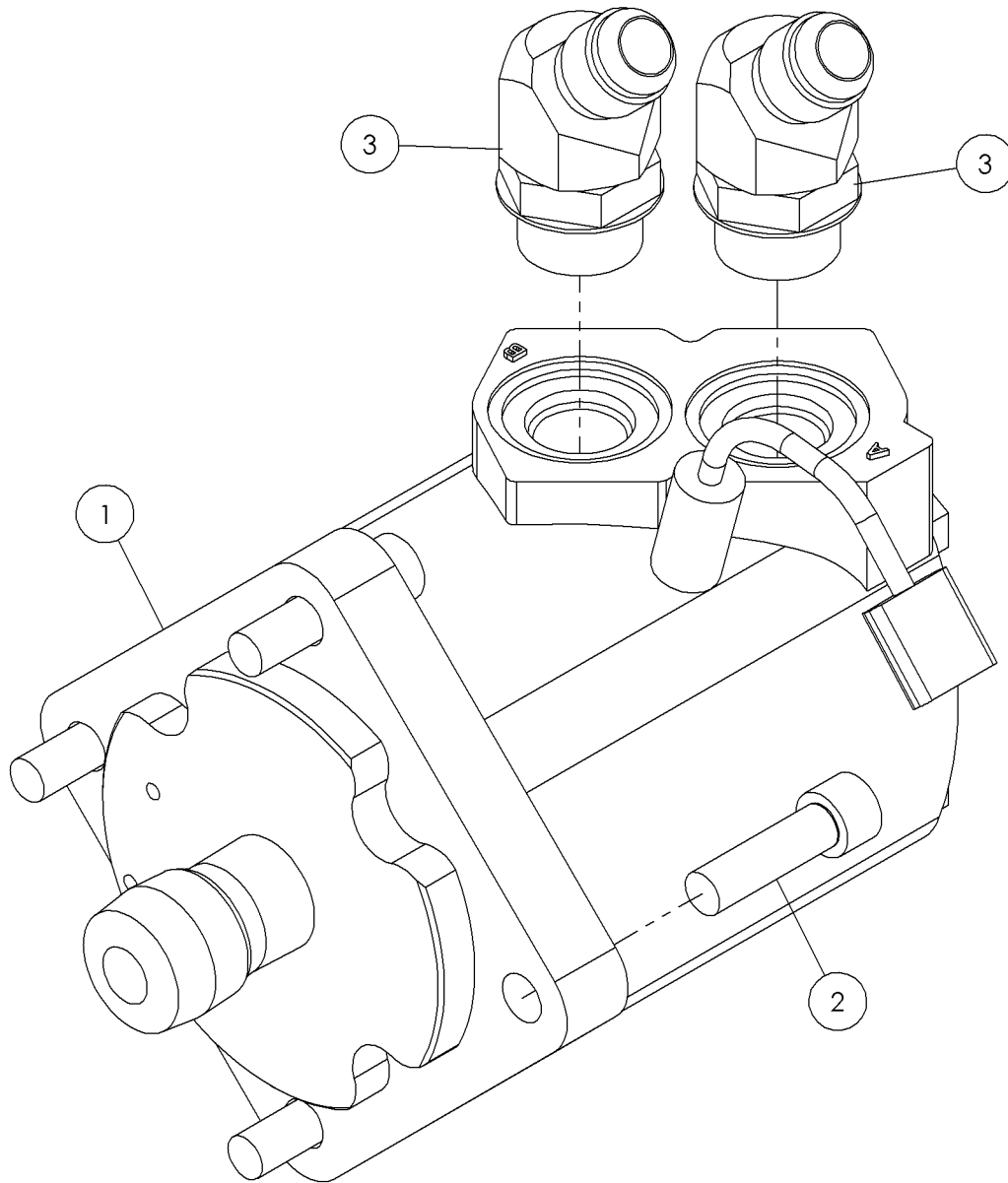
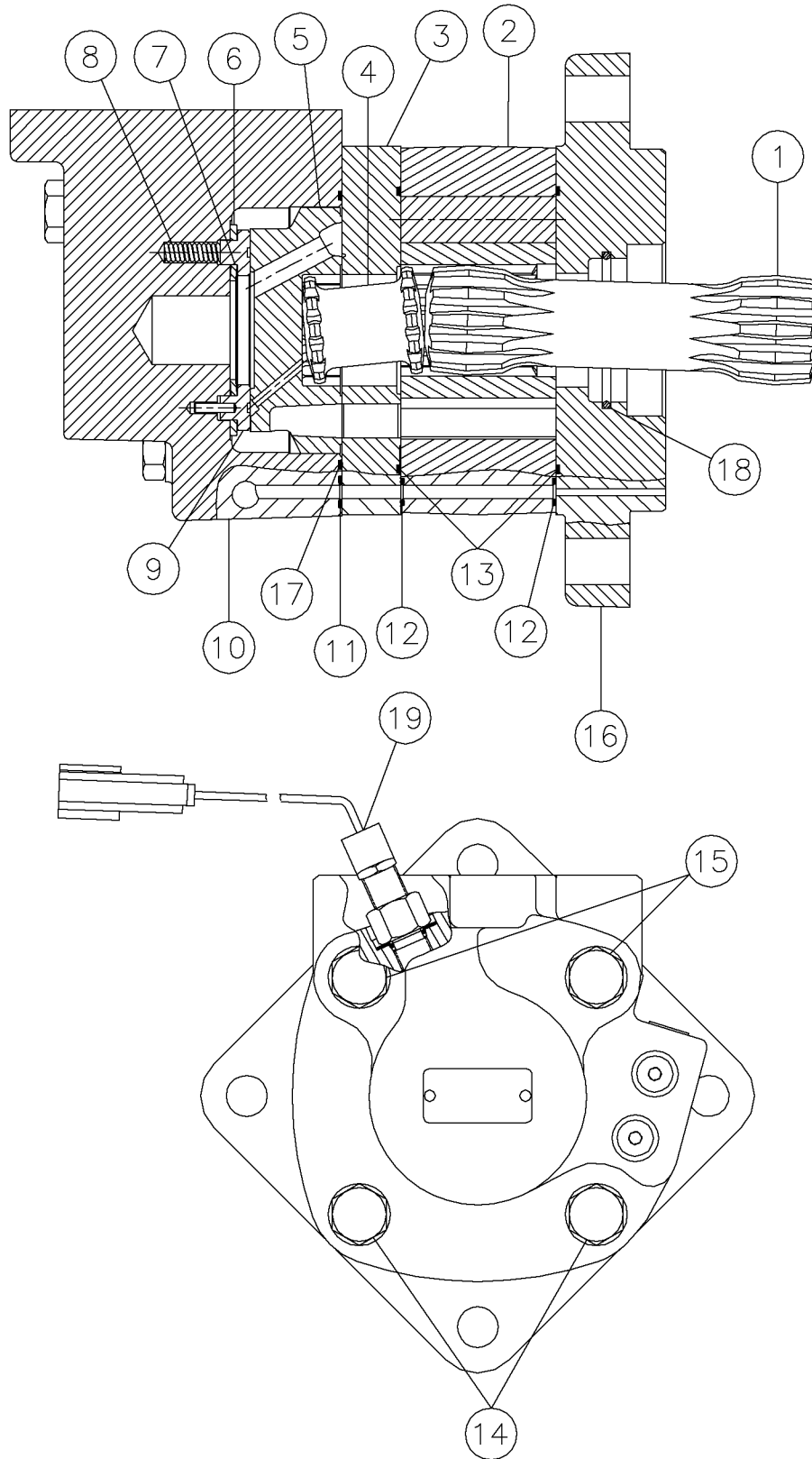

Illustration No. 296280899

## Drive Motor-70 GPM APLEX Fig 11-6

REF. NO.	*	PART NO.	DESCRIPTION	QTY.	REMARKS
1		296284063	MOTOR-BEARINGLESS 19 CID	1	Breakdown Fig. 11-6z01
2		229144001	CAPSCREW- 1/2-13 X 1 3/4SOC.HD	4	
3		81212001	FITTING-16MX12M JIC 45 ELBOW	2	

Components-Motor 70 GPM APLEX Fig 11-6z01





## Components-Motor 70 GPM APLEX Fig 11-6z01

REF. NO.	*	PART NO.	DESCRIPTION	QTY.	REMARKS
1		296285070	DRIVE	1	
2		296285071	GEROLER ASSY	1	
3		296285072	PLATE-VALVE	1	
4		215338013	DRIVE-VALVE	1	
5		296285073	VALVE	1	
6		776045	SEAL-FACE OUTER 6992	1	
7		296285074	SEAL-INNER	1	
8		296285075	SPRING - COMPRESSION	1	
9		209137015	BALANCE PLATE ASSEMBLY	3	
10		296285076	HOUSING VALVE	1	
11		770041	SEAL-O RING 9022-12	1	
12		215338009	SEAL	1	
13		209137007	SEAL-3 3/4"ID - (O-RING)	2	
14		255509033	BOLT-5.45	2	
15		255509031	BOLT-6.79	2	
16		296285077	FLANGE-MOUNTING	2	
17		752005	SEAL-O RING 15062	1	
18		215338003	SEAL	1	
19		251106009	SPEED PICKUP - ELECTRONIC	1	
		296284063	MOTOR-BEARINGLESS 19 CID		Includes All Items In Figure
		296285078	COMPLETE SEAL KIT		
		296285079	REAR SEAL KIT		

Wash Wand Fig 11-7

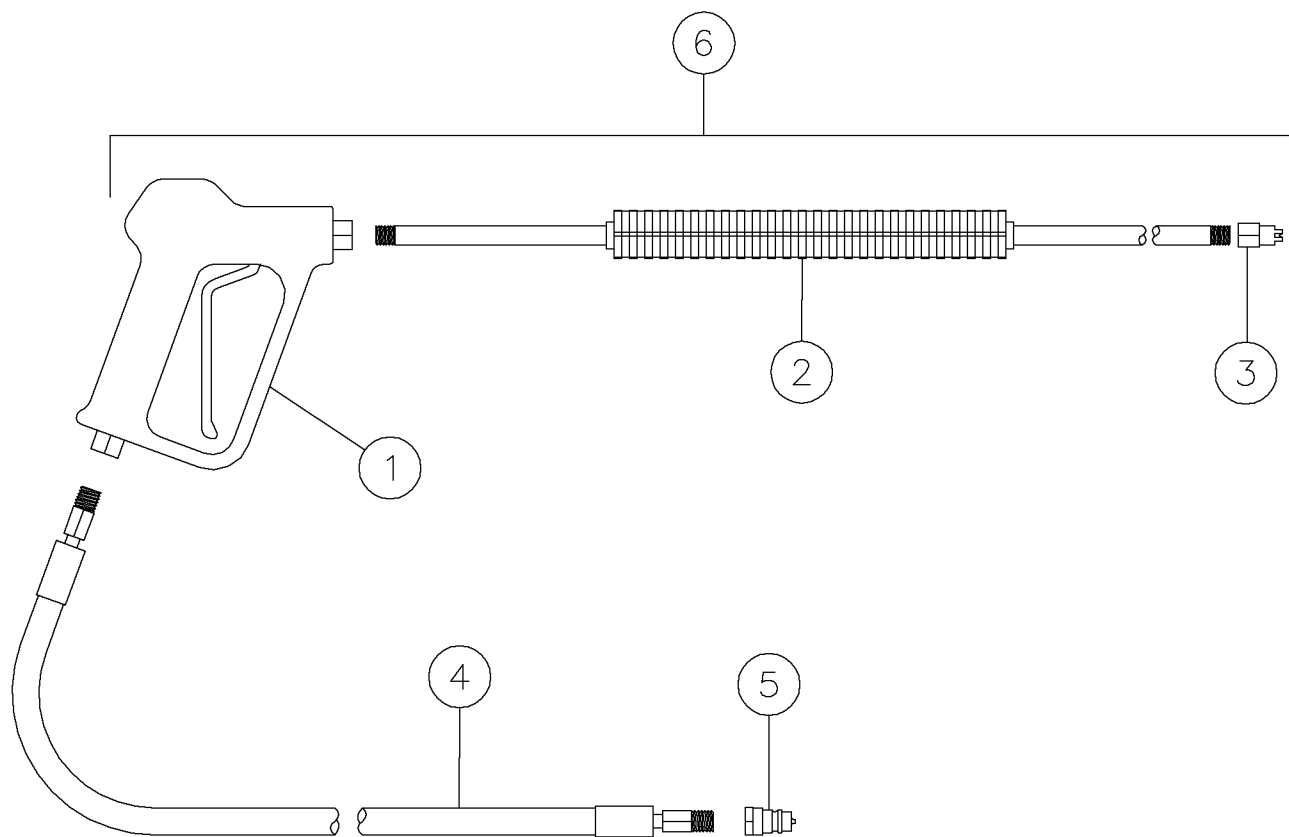

## Wash Wand Fig 11-7

REF. NO.	*	PART NO.	DESCRIPTION	QTY.	REMARKS
1		904578001	GUN HANDLE	1	
2		904577001	MOLDED LANCE	1	
3		904576001	SPRAY NOZZLE	1	
4		282761001	HOSE-3/8X500 3/8MSNPT/1/2MNPT 100R2	1	
5		227236001	COUPLER-1/2" NPT QUICK(MALE)	1	
6		285927001	GUN ASSY	1	
		240264001	WAND ASSY		Includes All Items In Figure

Cylinder-Water Shut Off Fig 11-8

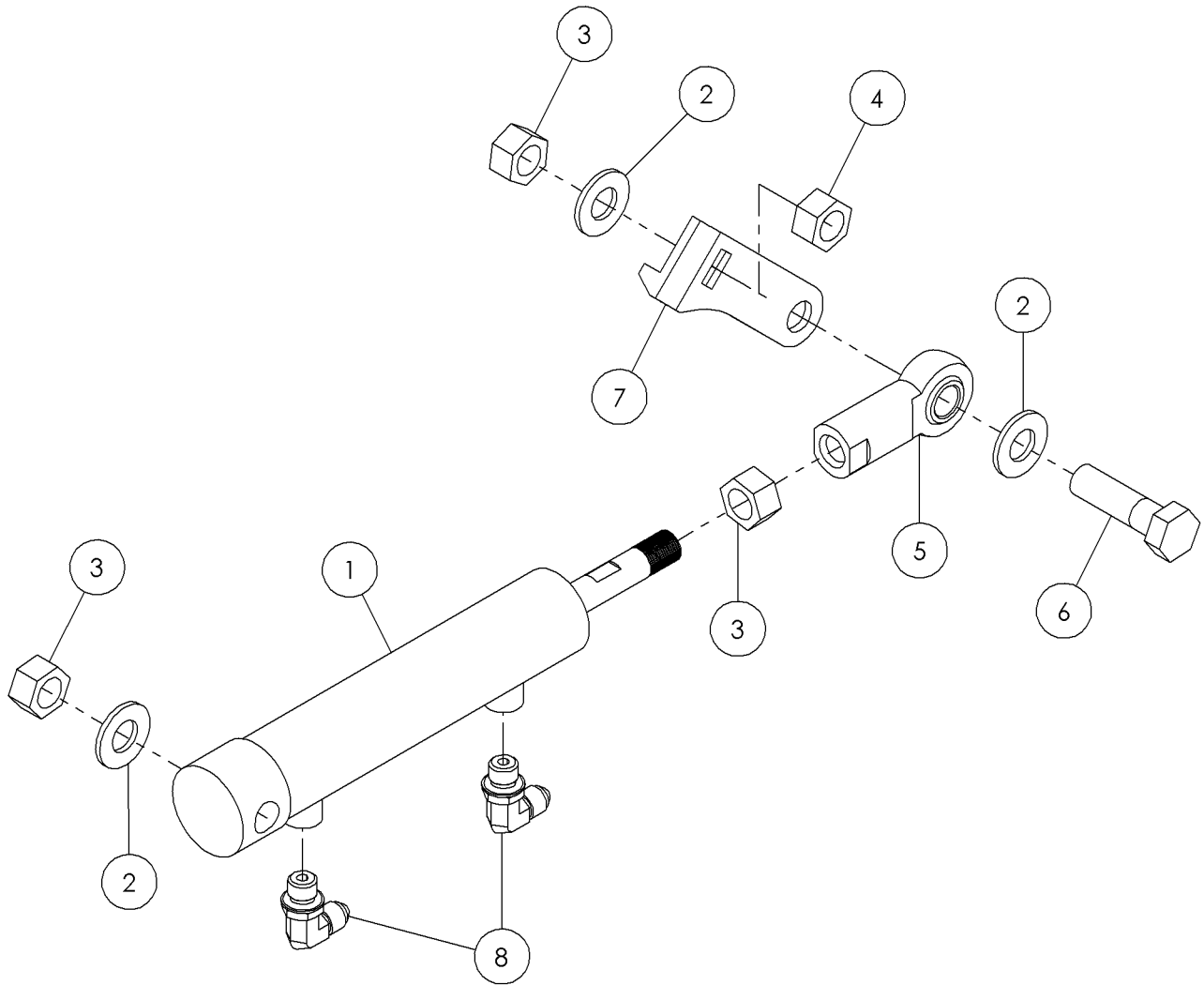
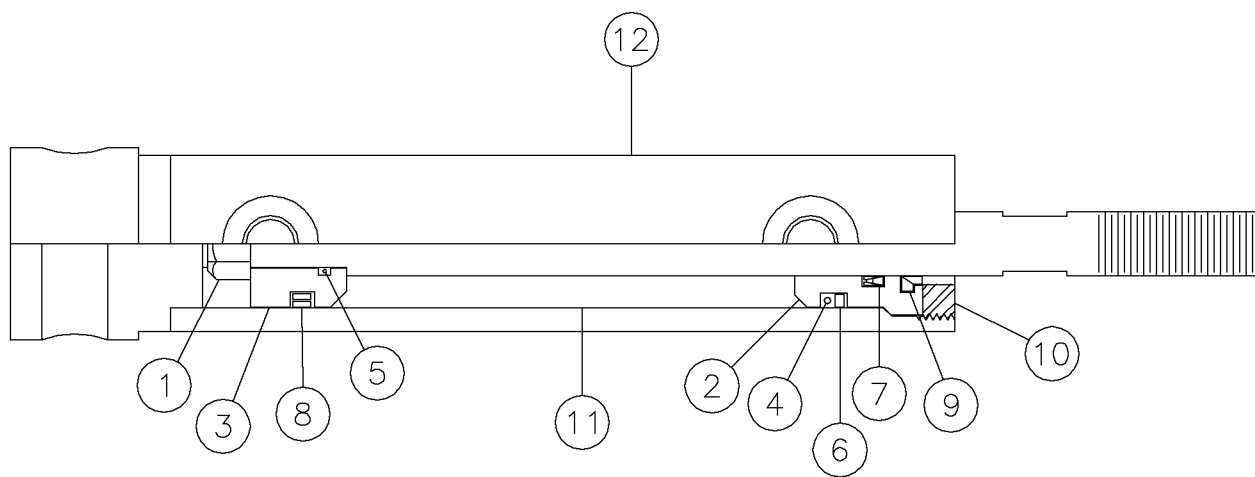

Illustration No. 296279929

## Cylinder-Water Shut Off Fig 11-8

REF. NO.	*	PART NO.	DESCRIPTION	QTY.	REMARKS
1		296285658	CYLINDER 1 X 3-1/2	1	Breakdown Fig. 11-8z01
2		485025	WASHER-1/2 FLAT-HARDENED-YZ	3	
3		250512001	NUT- 1/2 NC Gr8 TOP LOCK Y/ ZINC	3	
4		451001	NUT-1/2 N.F. HEX ZYC	1	
5		224291001	BALL JOINT-1/2-20 FEMALE THDS.	1	
6		240334001	SCREW-HCS-.50-13X1.75-GR8-YZ	1	
7		296275324	ARM - LEVER	1	
8		59423001	FIT-4M JICX4M ADJ.90 DEG.ELBOW	2	

Components-Cylinder Fig 11-8z01



## Components-Cylinder Fig 11-8z01

REF. NO.	*	PART NO.	DESCRIPTION	QTY.	REMARKS
1			NUT	1	Not Sold Separately
2			HEAD	1	Not Sold Separately
3			PISTON	1	Not Sold Separately
4			O-RING	1	Not Sold Separately
5			O-RING	1	Not Sold Separately
6			BACKUPS	3	Not Sold Separately
7			BS SEAL	1	Not Sold Separately
8			PSP SEAL	1	Not Sold Separately
9			DUST SEAL	1	Not Sold Separately
10			COLLAR	1	Not Sold Separately
11		296285210	SHAFT	1	
12			BARREL WITH CLEVIS AND PORTS	1	
		296285658	CYLINDER 1 X 3 1/2		Includes All Items In Figure
		296285211	SEAL KIT		Inc Items 4 thru 9

Water Valve-15' Fig 11-9

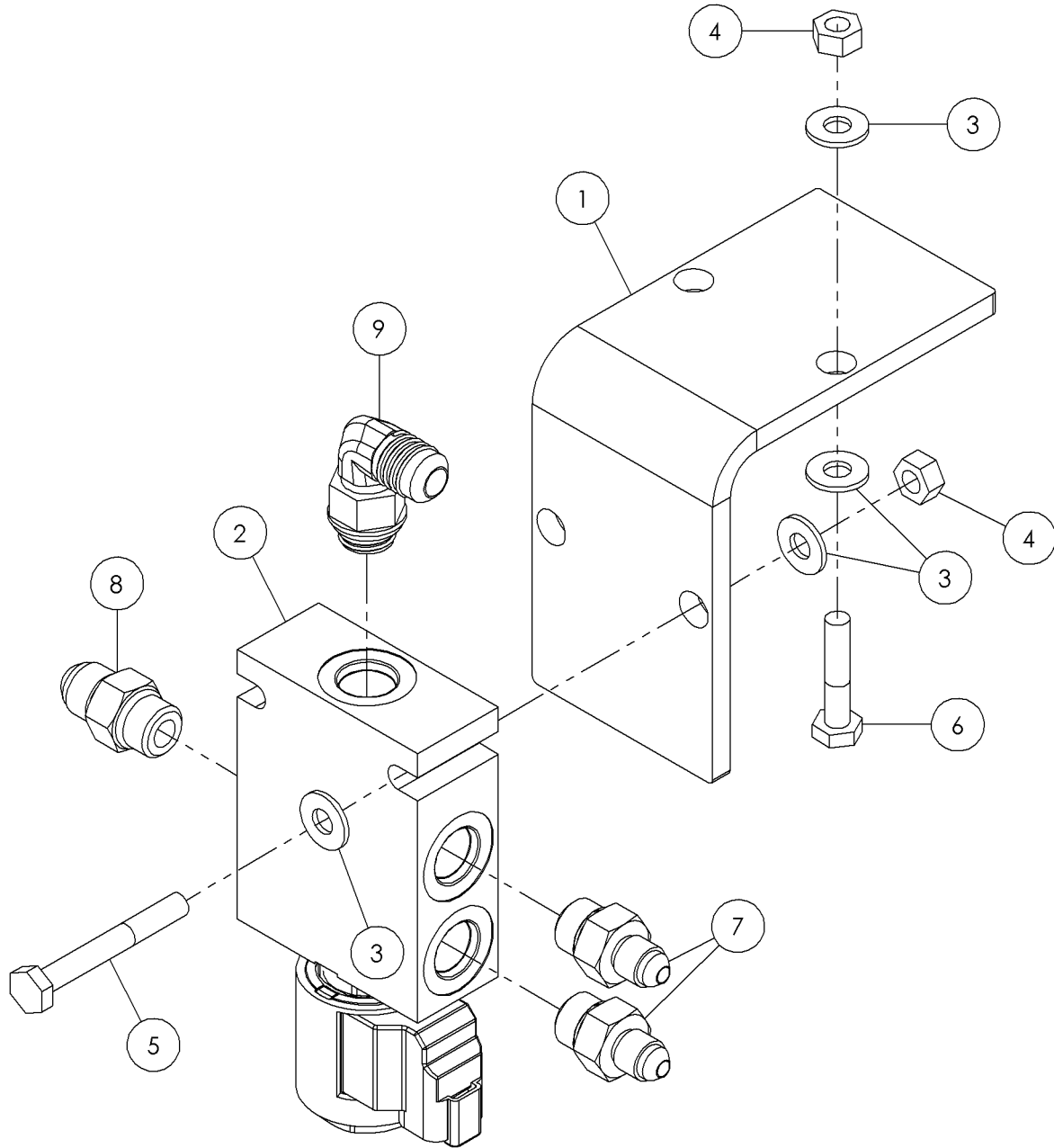

Illustration No. 296279885



## Water Valve-15' Fig 11-9

REF. NO.	*	PART NO.	DESCRIPTION	QTY.	REMARKS
1		296280975	BRACKET - VALVE MOUNT	1	Breakdown Fig. 7-7z02
2		294901001	VALVE - GREASER	1	
3		235716001	WASHER-FLATSTRL-.25-.28X.63-.06-CZ	8	
4		248198001	NUT-1/4 - 20 GR8 TOP LOCK ZINC	4	
5		248197001	BOLT-1/4-20X2 GR.8 ZINC PLTD	2	
6		250008001	BOLT 1/4-20 X 1 1/4 ZINC PL	2	
7		57968001	FITTING-STR-4MJ-6MORB	2	
8		65565001	FITTING - 6M O-RING X 6M JIC ST.	1	
9		59426001	FITTING - 90-6MJ-6MORBA	1	

Two Speed Valve Fig 11-10

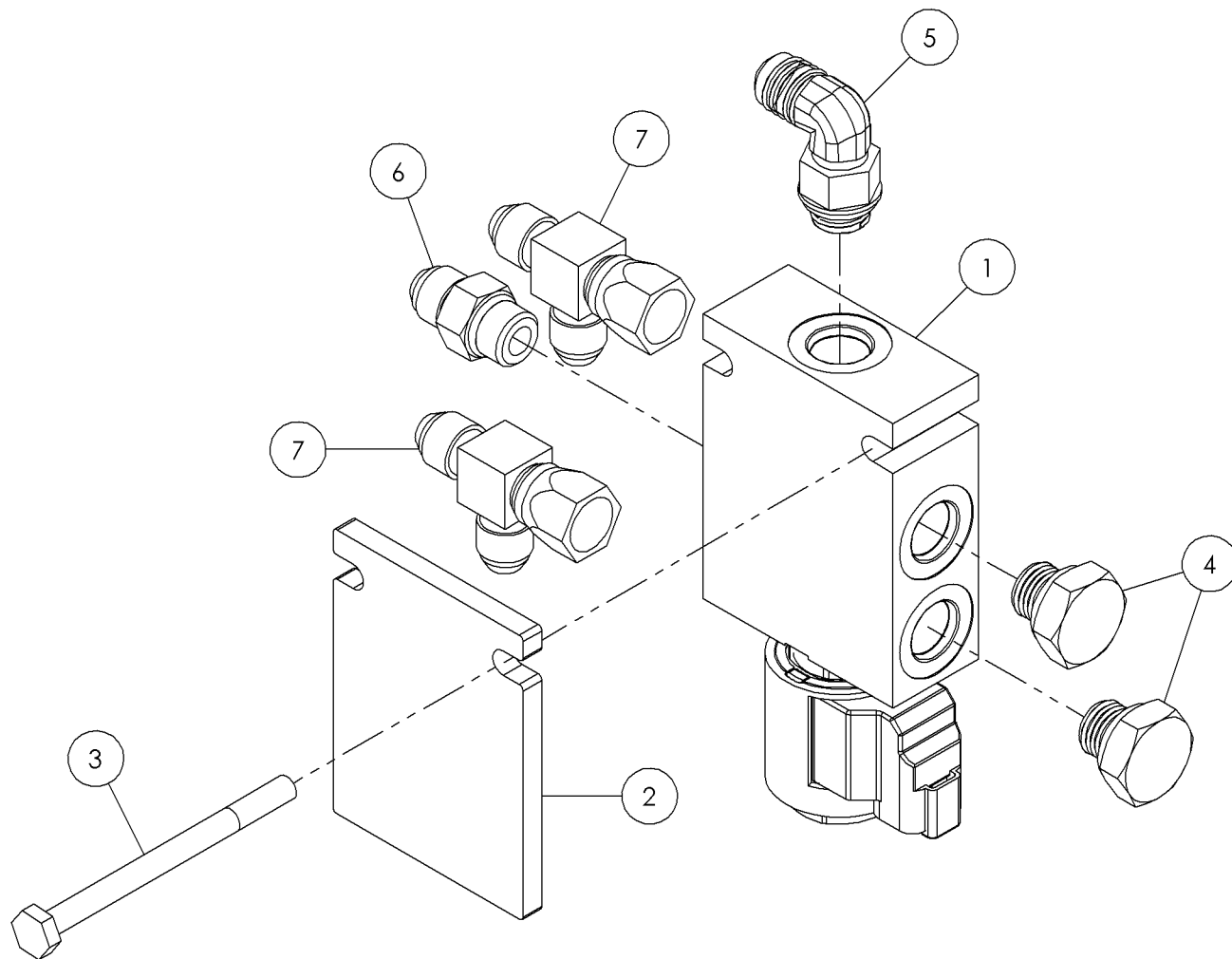

Illustration No. 296286556

## Two Speed Valve Fig 11-10

REF. NO.	*	PART NO.	DESCRIPTION	QTY.	REMARKS
1		294901001	VALVE - GREASER	1	Breakdown Fig. 7-7z02
2		296286557	PLATE - VALVE SPACER	1	
3		350032	BOLT - HEX 1/4 - 20 X 3 1/4	2	
4		5553001	FITTING - PLUG - 6MORB - HEX	2	
5		59426001	FITTING - 90-6MJ-6MORBA	1	
6		65565001	FITTING - 6M O-RING X 6M JIC ST.	1	
7		59427001	TEE-6MJ-6FSJ-6MJ	2	

Water Valve-10' Fig 11-11

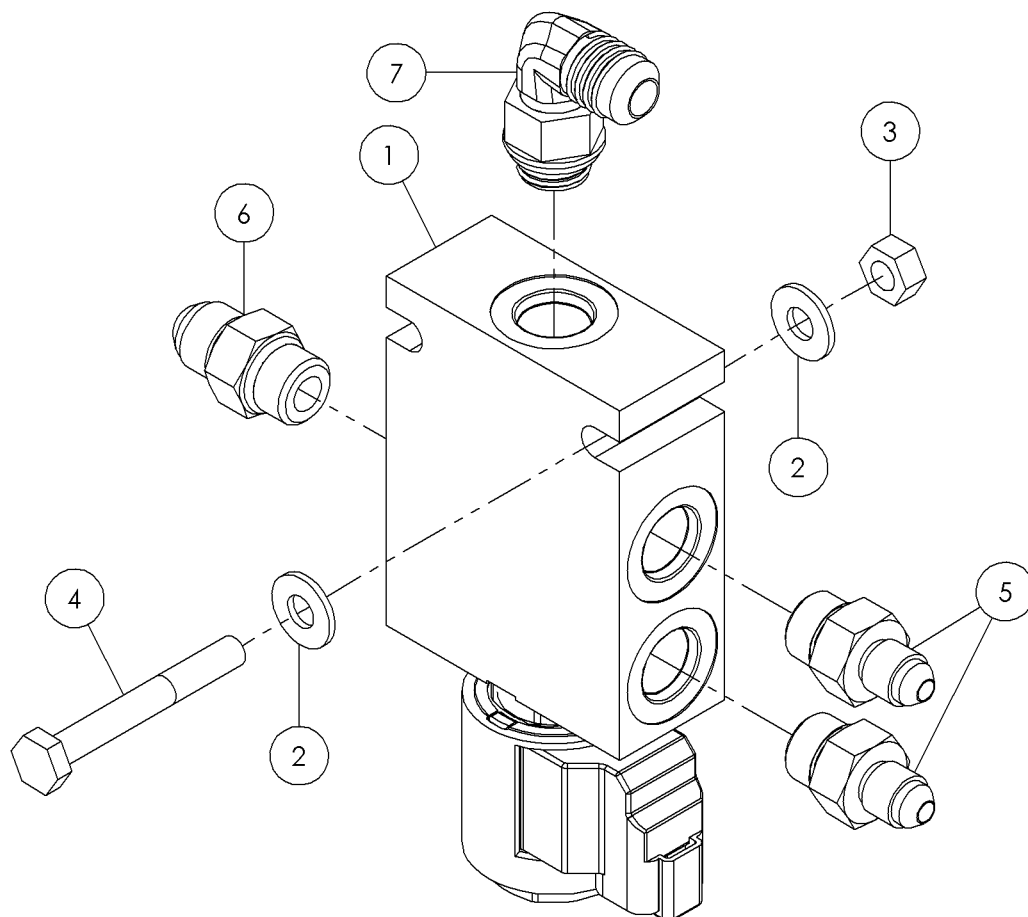

Illustration No. 296279885

## Water Valve-10' Fig 11-11

REF. NO.	*	PART NO.	DESCRIPTION	QTY.	REMARKS
1		294901001	VALVE - GREASER	1	Breakdown Fig. 7-7z02
2		235716001	WASHER-FLATSTRL-.25 -.28X .63-.06-CZ	4	
3		248198001	NUT-1/4 - 20 GR8 TOP LOCK ZINC	2	
4		248197001	BOLT-1/4-20X2 GR.8 ZINC PLTD	2	
5		57968001	FITTING-STR-4MJ-6MORB	2	
6		65565001	FITTING - 6M O-RING X 6M JIC ST.	1	
7		59426001	FITTING - 90-6MJ-6MORBA	1	

Rockfire Fitting Fig 11-12

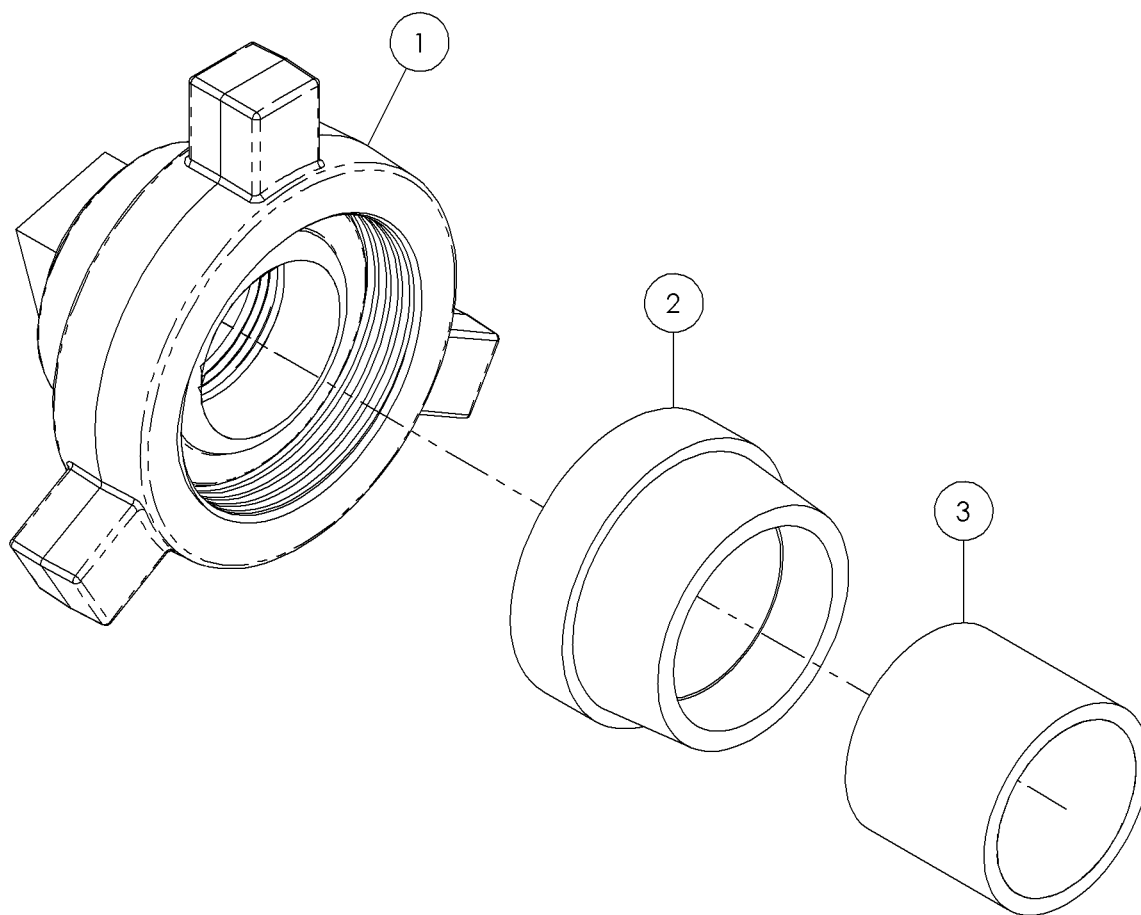

Illustration No. 296287939

## Rockfire Fitting Fig 11-12

REF. NO.	*	PART NO.	DESCRIPTION	QTY.	REMARKS
1		296259782	ASSY-CAP-2.00"-HYD-HAMMER	1	Breakdown Fig. 11-12z01
2		296259780	UNION - MALE	1	
3		240674001	NIPPLE-2" NPT CLOSE GALVANIZD	1	

Components-Cap 2" Fig 11-12z01

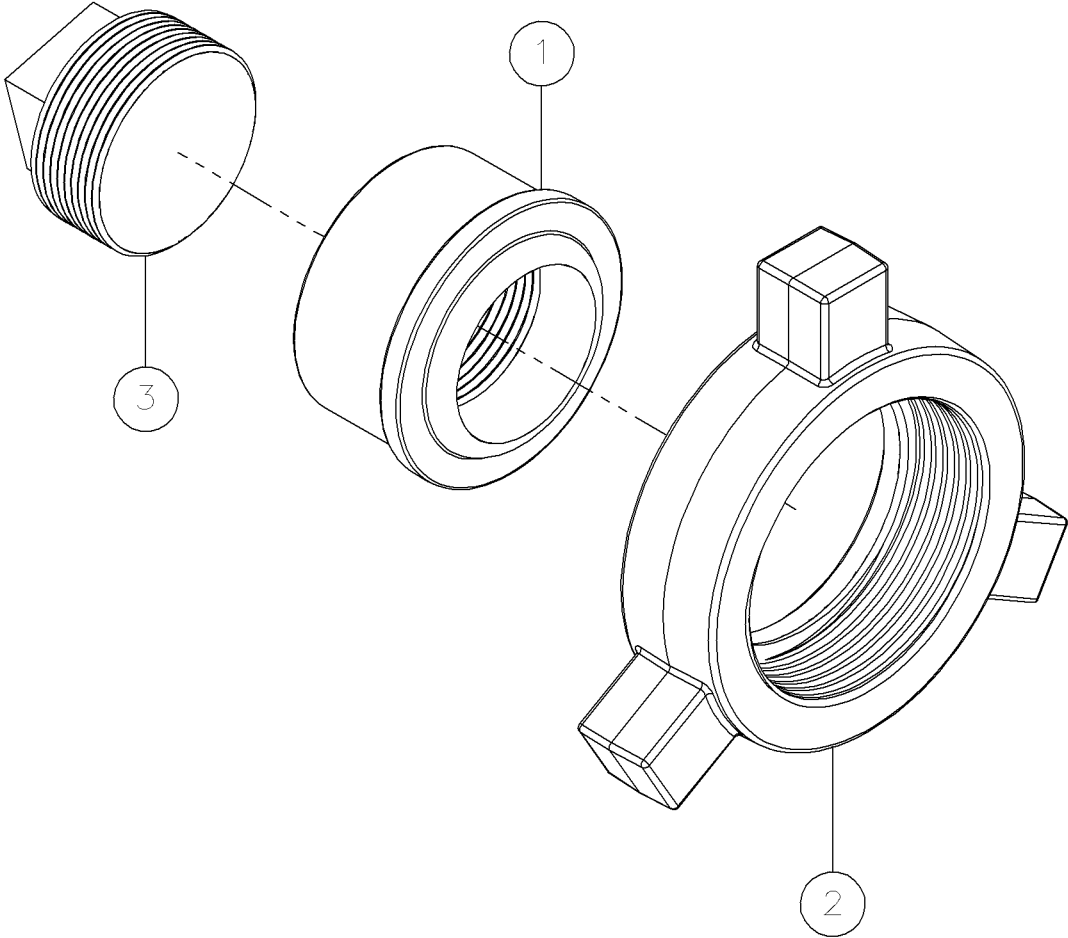

Illustration No. 296259782



## Components-Cap 2" Fig 11-12z01

REF. NO.	*	PART NO.	DESCRIPTION	QTY.	REMARKS
1		296259781	FITTING-STR-32FNPT-3000PSI	1	
2		296259779	NUT-WING-32HU-3000PSI	1	
3		296258568	FITTING - PLUG - 32MNPT - SQ - GALV	1	

Rotation System Fig 12-1

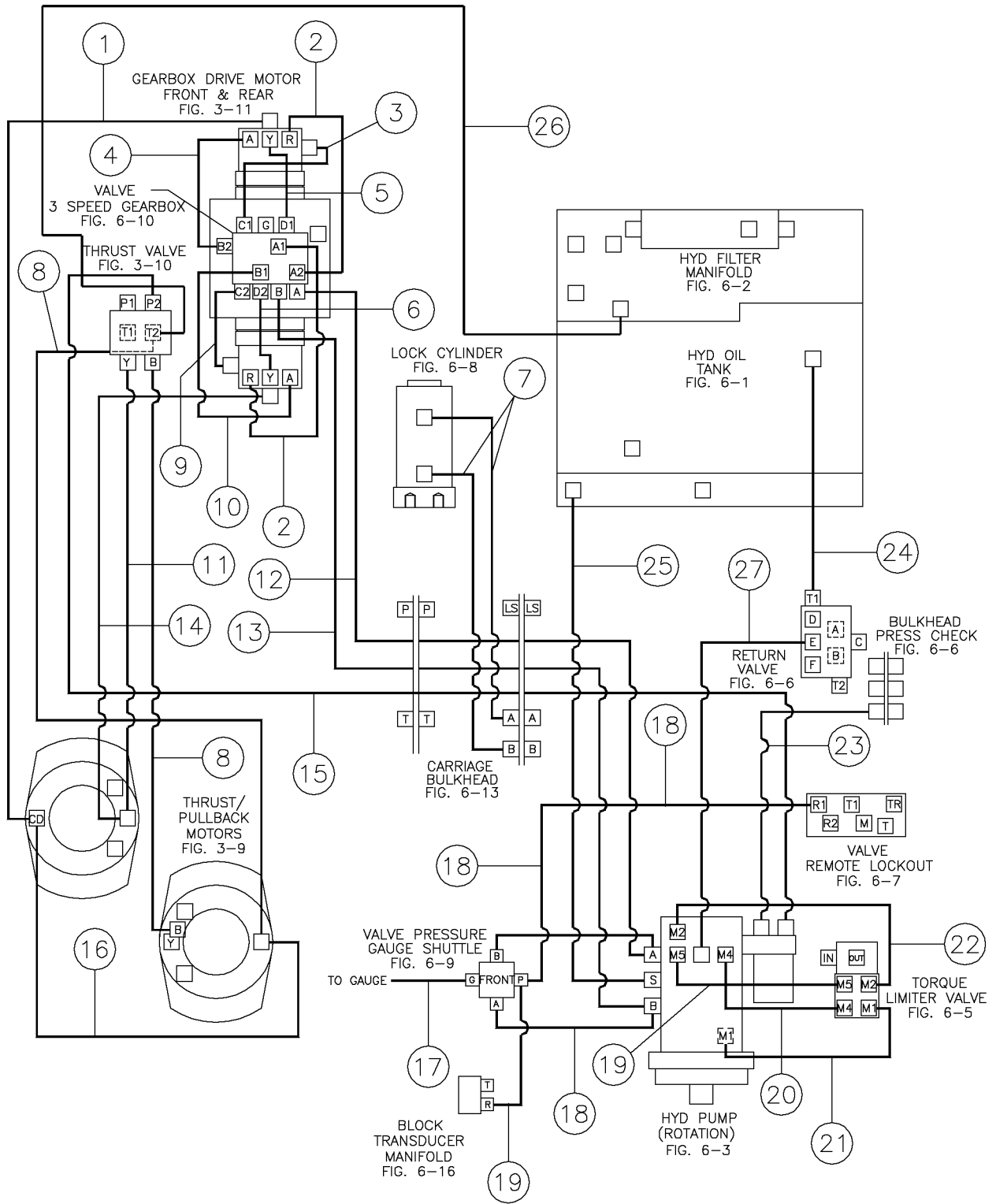

## Rotation System Fig 12-1

REF. NO.	*	PART NO.	DESCRIPTION	QTY.	REMARKS
1		296284029	HOSE- HYD .5X 36-8FSJ ST/90 3000 PSI	1	10 FT/15 FT
2		296284031	HOSE-HYD 1.0X38 16FSORFF ST/ST 6000 PSI	2	10 FT/15 FT
3		296280953	HOSE-HYD .50X20" 8FSJ ST/ST 3000 PSI	1	10 FT/15 FT
4		296284033	HOSE-HYD 1.0X43 -16FSORFF-ST/ST 6000 PSI	1	10 FT/15 FT
5		296284040	HOSE-HYD-.38X11.5-6FSJ-ST/ST-3000 PSI	1	10 FT/15 FT
6		296284041	HOSE-HYD-.38X13-6FSJ-ST/ST 3000 PSI	1	10 FT/15 FT
7		296280947	HOSE-1/4X240 4FS ST/90 JIC 3000 PSI	2	15 FT
		296286531	HOSE - 1/4 X 213 4FS ST/90 JIC 3000 PSI	2	10 FT
8		296284030	HOSE-HYD .5X35 8FSJ ST/45 PSI	2	10 FT/15 FT
9		296284036	HOSE-HYD .5X16 8FSJ ST/ST 3000 PSI	1	10 FT/15 FT
10		296303769	HOSE-HYD 1.0X37 - 16FSORFF ST/45 6000	1	10 FT/15 FT
11		296284037	HOSE-HYD-.38X27-6FSJ-ST/ST 3000 PSI	1	10 FT/15 FT
12		296303753	HOSE-HYD 1.00X268" 16FSORFF- 16CD62 45 DEG 6000PSI	1	15 FT
		296303764	HOSE-1.00 X 264 16FSORFF/16CD 62 ST/45	1	10 FT
13		296303753	HOSE-HYD 1.00X268" 16FSORFF- 16CD62 45 DEG 6000PSI	1	15 FT
		296303765	HOSE - 1.00 X 253 16 FSORFF/16CD62 ST/LL	1	10 FT
14		296284028	HOSE-HYD .5X18" -8FSJ ST/90 3000 PSI	1	10 FT/15 FT
15		296280934	HOSE-HYD 1/00X42" 16FSORFF-ST/L90 6000	1	15 FT
		296286530	HOSE - 1/4 X 249 4FS ST/90 JIC 3000 PSI	1	10 FT
16		296284035	HOSE-HYD .50X28-8FSJ ST/45 3000 PSI	1	10 FT/15 FT
17		244520001	HOSE-.078X136 4FS JIC ST	1	10 FT/15 FT
18		285556001	HOSE - .078 X 18 4 FS JIC ST/ST 6900 PSI	3	10 FT/15 FT
19		278941001	HOSE - 1/4 X 11 FFOR ST/ST 6000 PSI	2	10 FT/15 FT
20		278942001	HOSE - 1/4 X 11 FFOR ST/90 6000 PSI	1	10 FT/15 FT
21		278944001	HOSE - 1/4 X 26 FFOR ST/90 6000 PSI	2	10 FT/15 FT
22		278806001	HOSE-1X30 16FSJIC ST/90 250PSI	1	10 FT/15 FT
23		278943001	HOSE - 1/4 X 13 FFOR ST/ST 6000 PSI	1	15 FT
		296286533	HOSE - 1/2 X 258 8FS ST/ST JIC 3000 PSI	1	10 FT
24		296273675	HOSE- 1.0 X 15.5 - GMV	1	10 FT/15 FT
25		278806001	HOSE-1X30 16FSJIC ST/90 250PSI	1	10 FT/15 FT
26		296286533	HOSE - 1/2 X 258 8FS ST/ST JIC 3000 PSI	1	10 FT
		296280956	HOSE-1/2X284 8FS ST/ST JIC 3000 PSI	1	15 FT
27		296273675	HOSE- 1.0 X 15.5 - GMV	1	10 FT/15 FT

Thrust/Pullback Fig 12-2

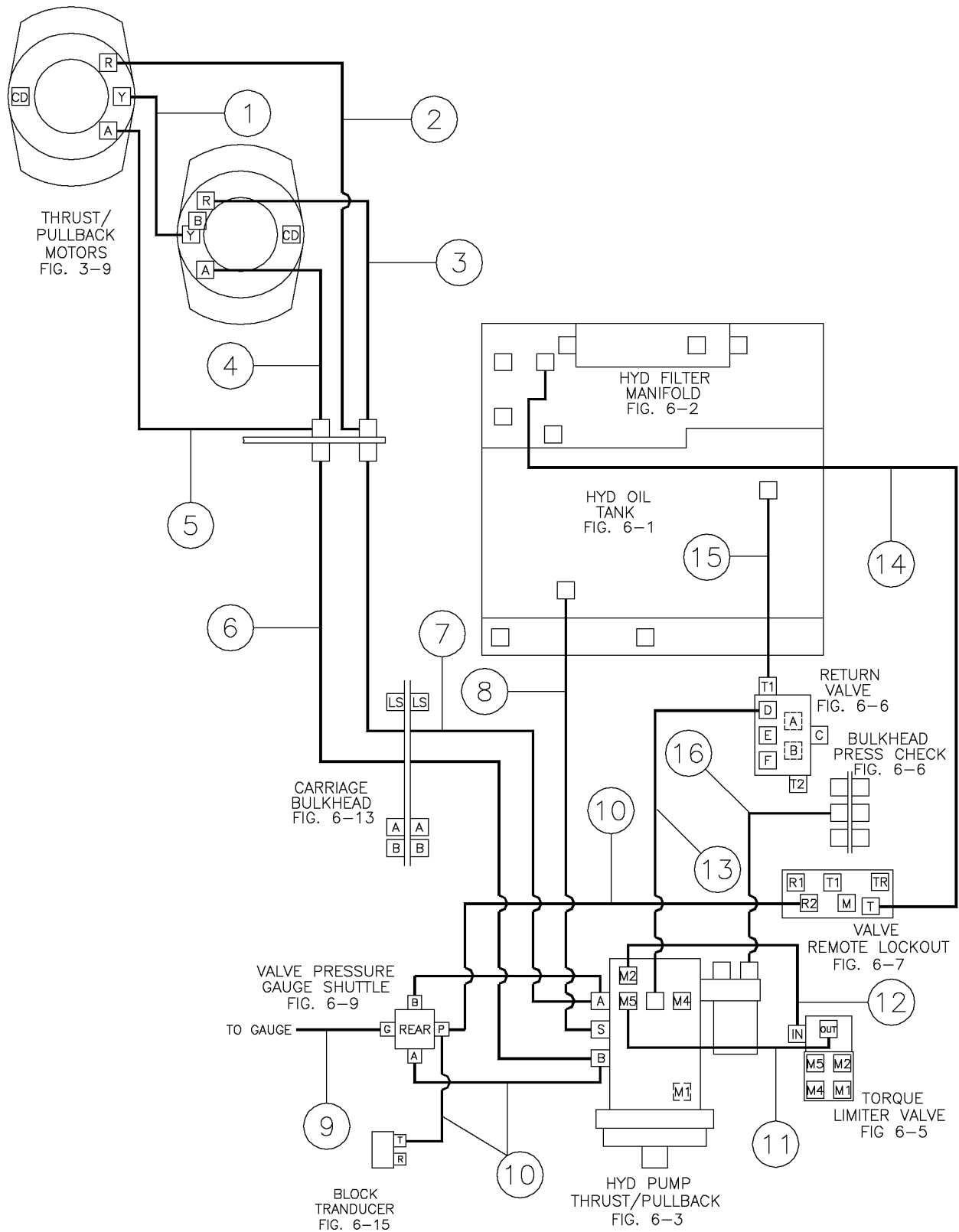

## Thrust/Pullback Fig 12-2

REF. NO.	*	PART NO.	DESCRIPTION	QTY.	REMARKS
1		296284039	HOSE-HYD-.38X15-6FSJ-ST/90-3000 PSI	1	10 FT/15 FT
2		296280931	HOSE WP 42,0 MPa 6000 PSI MSHA IC 40/26	1	10 FT/15 FT
3		296280933	HOSE-HYD 1.00X42" 16FSORFF-ST/L90 6000	1	10 FT/15 FT
4		296280932	HOSE-HYD 1.00X24" 16FSORFF-ST/90 6000PSI	1	10 FT/15 FT
5		296284034	HOSE -HYD 1.0X25 16FSORFF-ST/45 6000 PSI	1	10 FT/15 FT
6		296303752	HOSE-HYD 1.00X229" 16FSORFF-16CD62 45 DEG 6000 PSI	1	15 FT
		296303765	HOSE-HYD-1X248-16FSORFF-16CD62-45 D-6000 PSI W/BLK	1	10 FT
7		296303752	HOSE-HYD 1.00X229" 16FSORFF-16CD62 45 DEG 6000 PSI	1	15 FT
		296303765	HOSE-HYD-1X248-16FSORFF-16CD62-45 D-6000 PSI W/BLK	1	10 FT
8		296273711	HOSE-1.0X16-16FJX STR/90M-GMV	1	10 FT/15 FT
9		244520001	HOSE-.078X136 4FS JIC ST	1	10 FT/15 FT
10		285556001	HOSE - .078 X 18 4 FS JIC ST/ST 6900 PSI	3	10 FT/15 FT
11		285556001	HOSE - .078 X 18 4 FS JIC ST/ST 6900 PSI	1	10 FT/15 FT
12		296273679	HOSE - 1.0 X 23 - 16FSJ/NONE - 16GMV	1	10 FT/15 FT
13		296273675	HOSE- 1.0 X 15.5 - GMV	1	10 FT/15 FT
14		296280937	HOSE-1/4 X 48 4FS ST/90 JIC 3000 PSI	1	10 FT/15 FT
15		296258418	HOSE - .08 X 14 4FS JIC ST/ST MICRO	1	10 FT/15 FT

Implement System Fig 12-3

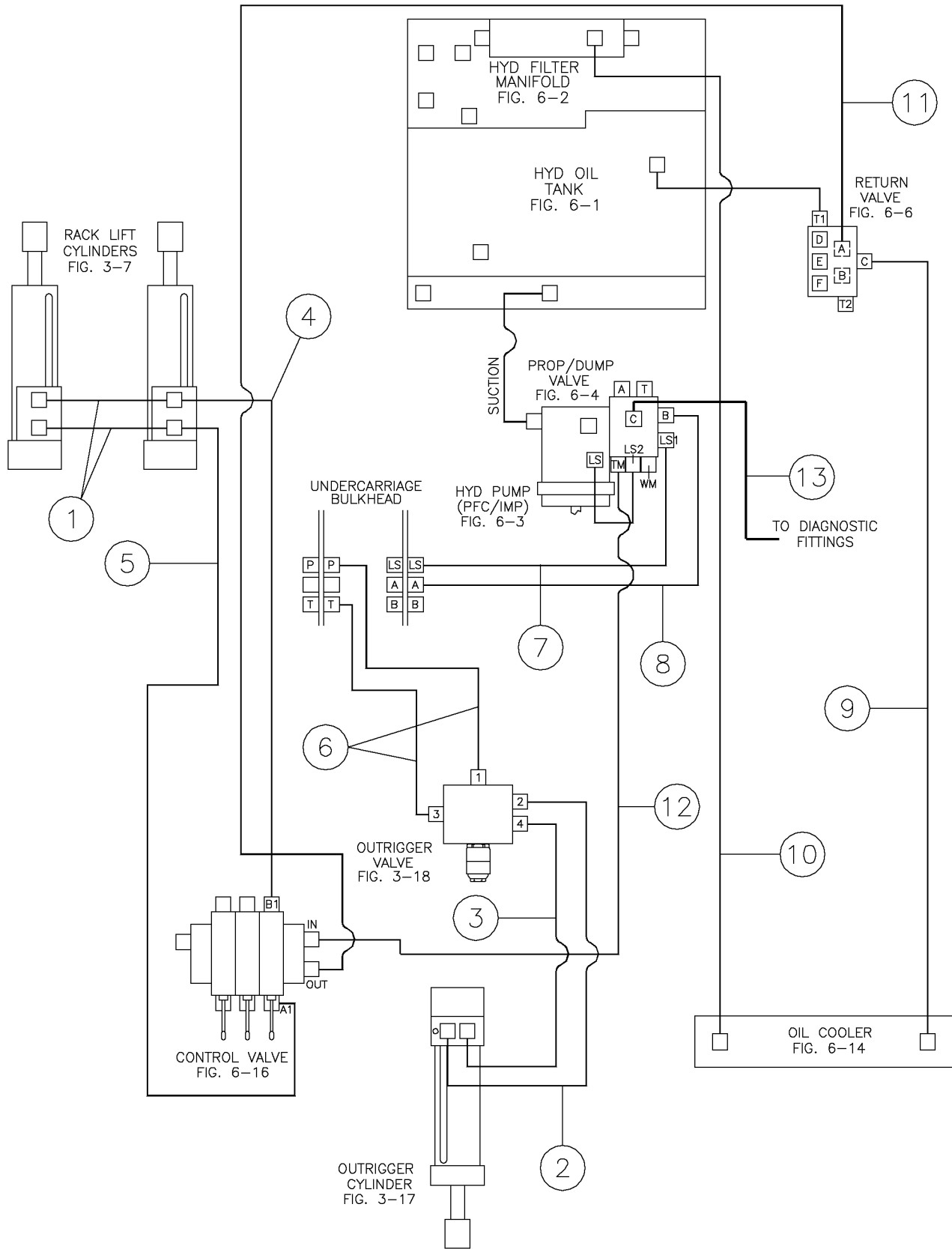

Implement System Fig 12-3

REF. NO.	*	PART NO.	DESCRIPTION	QTY.	REMARKS
1		278804001	HOSE-3/8X12 6FSJIC ST/90 M3K	2	10 FT/15 FT
2		57940719	HOSE-3/8X21 6FSJICST/45D3000#	1	15 FT
		257531001	HOSE-HYD 3/8 X 20 6FS JIC ST/45	1	10 FT
3		257531001	HOSE-HYD 3/8 X 20 6FS JIC ST/45	1	15 FT
		57940719	HOSE-3/8X21 6FSJICST/45D3000#	1	10 FT
4		296280939	HOSE-3/8 X 155 6FS JIC ST/90 3000 PSI	1	15 FT
		296286517	HOSE - 3/8 X 127 6FS ST/90 JIC 3000 PSI	1	10 FT
5		296280940	HOSE-3/8X148 6FS JIC ST/90 3000 PSI	1	15 FT
		296286518	HOSE-3/8 X 131 6FS ST/90 JIC 3000 PSI	1	10 FT
6		289119001	HOSE - 3/8 X 24 FSJIC ST/45 3000 PSI	2	10 FT/15 FT
7		257529001	HOSE-HYD 3/8 X 54 6FS JIC ST	1	10 FT/15 FT
8		296280936	HOSE-3/8 X 74 6FS JIC ST/90 3000 PSI	1	10 FT/15 FT
9		296279831	HOSE - 1.25" X 67" 20FSJIC ST/ST 250PSI	1	10 FT/15 FT
10		296279958	HOSE-1-1/4 X 70 20FSJIC ST/45 GMV	1	10 FT/15 FT
11		296280938	HOSE-3/4X182 12FS JIC ST/ST 3000 PSI	1	15 FT
		53845583	HOSE-3/4X163 12FS JIC 3000 PSI	1	10 FT
12		612950001	HOSE - 3/4 X 185 - 3000 PSI	1	10 FT/15 FT
13		285556001	HOSE - .078 X 18 4 FS JIC ST/ST 6900 PSI	1	10 FT/15 FT

Ground Drive System Fig 12-4

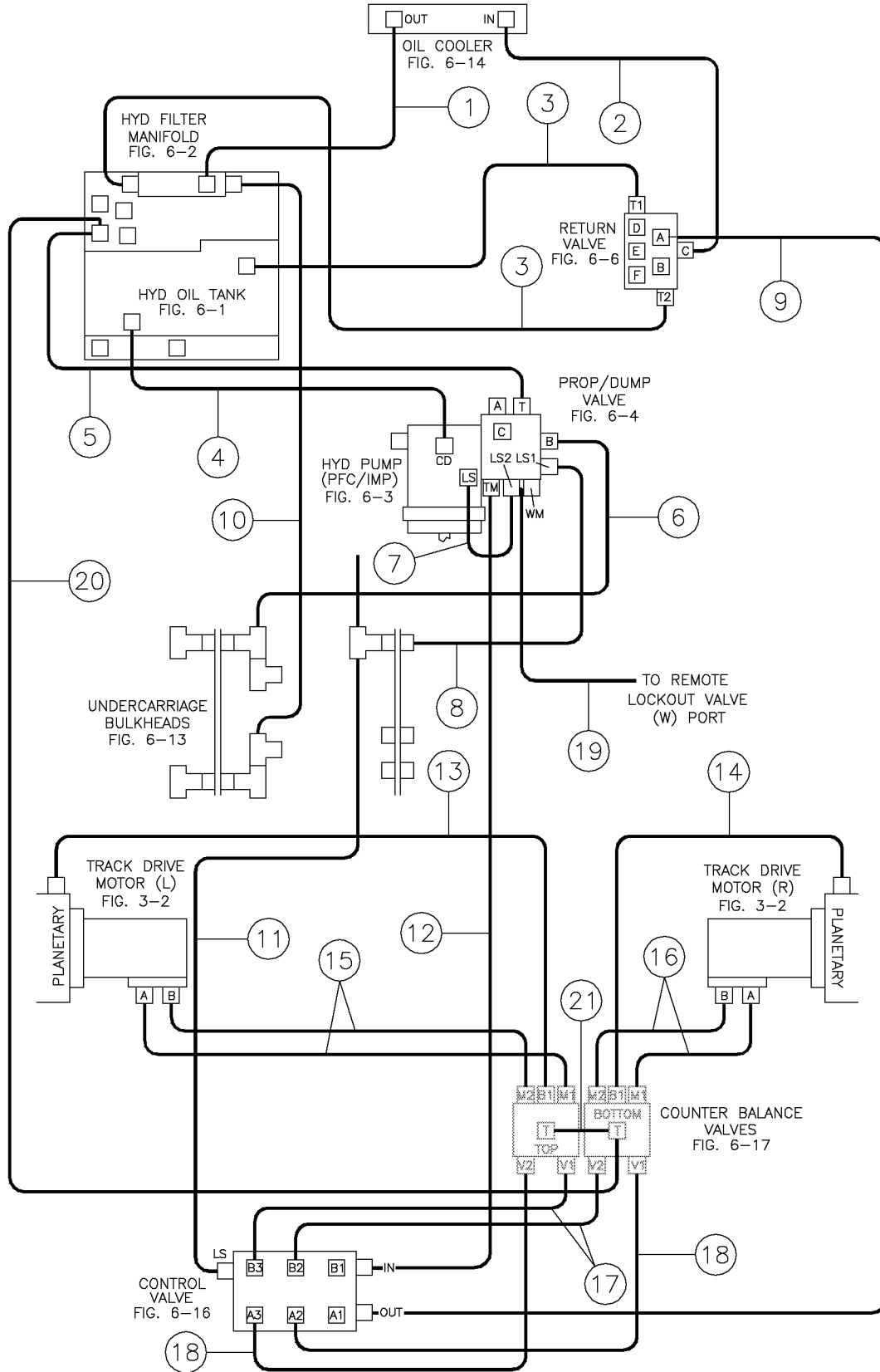



## Ground Drive System Fig 12-4

REF. NO.	*	PART NO.	DESCRIPTION	QTY.	REMARKS
1		296279958	HOSE-1-1/4 X 70 20FSJIC ST/45 GMV	1	10 FT/15 FT
2		296279831	HOSE - 1.25" X 67" 20FSJIC ST/ST 250PSI	1	10 FT/15 FT
3		278794001	HOSE-1X12 W/ NO ENDS 250 PSI	2	10 FT/15 FT
4		296256885	HOSE - .50 X 30 8FS JIC ST/90 M3K	1	10 FT/15 FT
5		296286525	HOSE - 1/4 X 43 4FS ST/ST JIC 3000 PSI	1	10 FT/15 FT
6		296280936	HOSE-3/8 X 74 6FS JIC ST/90 3000 PSI	1	10 FT/15 FT
7		57940445	HOSE-3/8X20 6FS JIC 3000 PSI	1	10 FT/15 FT
8		257529001	HOSE-HYD 3/8 X 54 6FS JIC ST	1	10 FT/15 FT
9		296280938	HOSE-3/4X182 12FS JIC ST/ST 3000 PSI	1	15 FT
9		53845583	HOSE-3/4X163 12FS JIC 3000 PSI	1	10 FT
10		296286516	HOSE-3/8X65 6FS ST/90 3000 PSI	1	10 FT/15 FT
11		296284003	HOSE-1/4X152 4FS JIC ST/90 3000 PSI	1	15 FT
11		296286571	HOSE - 1/4 X 122 4FS ST/90 JIC 3000 PSI	1	10 FT
12		612950001	HOSE - 3/4 X 185 - 3000 PSI	1	10 FT/15 FT
13		296303792	HOSE-1/4 X 98.4 FS ST/ST JIC 6000 PSI	1	15 FT
13		296303774	HOSE-1/4X78.4 FS ST/ST JIC 6000 PSI	1	10 FT
14		296303793	HOSE-1/4 X 120.4 FS ST/ST JIC 6000 PSI	1	15 FT
14		296303775	HOSE-1/4X94.4 FS ST/ST JIC 6000 PSI	1	10 FT
15		296303755	HOSE-HYD-.75X89-12FS JIC ST/ST- 3000PSI-M3K	2	15 FT
15		296299407	HOSE - 3/4 X 62 12FS JIC 3000PSI	2	10 FT
16		296303756	HOSE-HYD-.75X114"12FS JIC ST/ST - 3000PSI	2	15 FT
16		296256893	HOSE - .75 X 87 12 FS JIC ST/ST M3K	2	10 FT
17		53845727	HOSE-3/4X32 12FSJICST/90 3000	2	10 FT/15 FT
18		53845409	HOSE-3/4X36 12FSJICST/12FSJC90	2	10 FT/15 FT
19		53843183	HOSE-1/4X18 4FS JIC 3000 PSI	1	10 FT/15 FT
20		296303794	HOSE-1/4X152.4 FS ST/90 JIC 6000 PSI	1	15 FT
20		296303789	HOSE-1/4X136.4 FS ST/90 JIC 6000 PSI	1	10 FT
21		296303803	HOSE-1/4 X 18 4FS ST/ST JIC 6000 PSI	1	10 FT/15 FT



Stakedown Fig 12-5

REF. NO.	*	PART NO.	DESCRIPTION	QTY.	REMARKS
1		232125001	HOSE - HYD - 3/8 X 22 6FS JIC ST/ST	1	15 FT
		57940209	HOSE-3/8X30 6FS JIC (3000PSI)	1	10 FT
2		278840001	HOSE-3/8X90 6FSJIC ST/90 M3K	1	15 FT
		296299406	HOSE - 3/8 X 98 6FS ST/90 JIC 3000PSI	1	10 FT
3		278843001	HOSE-3/8X92 6FSJIC ST/90 M3K	1	15 FT
		257521001	HOSE-HYD 3/8 X 100" 6FS JIC ST/90	1	10 FT
4		57940259	HOSE-3/8X42 6FS JIC 3000 PSI	1	15 FT
		57940289	HOSE-3/8X50 6FS JIC 3000 PSI	1	10 FT
5		57940619	HOSE-3/8X49 6FS JIC ST/90	1	15 FT
		296280238	HOSE-3/8 X 49 6FS ST/90 JIC PSI 3000	1	10 FT
6		261377001	HOSE-HYD-.38X169-6FSJ-ST/90-3000PSI-M3K	2	15 FT (P And T Port)
		296286535	HOSE-3/8 X 150 6FS ST/90 JIC 3000 PSI	2	10 FT (T Port And P)
7		296284027	1/4X51 4FS ST/90	1	10 FT/15 FT
8		279052001	HOSE-3/8 X 54 FSJIC X FSJIC 90	2	15 FT
		279052001	HOSE-3/8 X 54 FSJIC X FSJIC 90	1	10 FT
9		278841001	HOSE-3/8X63 6FSJIC ST/90 M3K	2	15FT
		261278001	HOSE-HYD-.38X74-6FSJ-ST/90-3000PSI-100R17-M3KMTF	2	10 FT
10		278271001	HOSE-3/8X17 6 FSJIC ST-90 M2T	1	15 FT
		296256871	HOSE - .375 X 26 6FS JIC ST/90 M3K	1	10 FT
11		296284025	HOSE-3/8X174 6FS JIC ST/45	1	15 FT
		296286522	HOSE-3/8 X 151 6FS JIC 3000 PSI	1	10 FT

Vise Clamp Fig 12-6

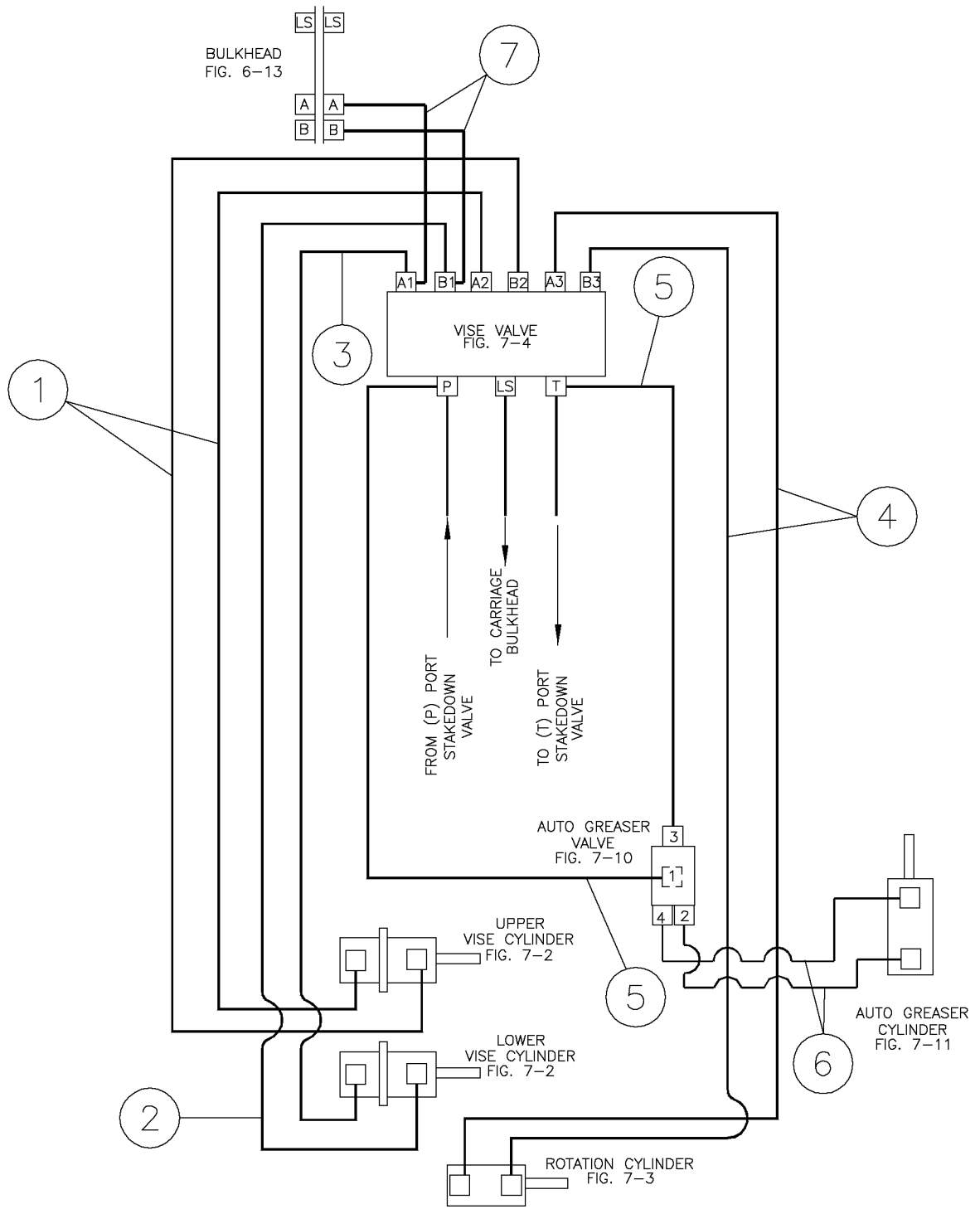

## Vise Clamp Fig 12-6

REF. NO.	*	PART NO.	DESCRIPTION	QTY.	REMARKS
1		53843325	HOSE-1/4X25 4FS JIC 3000 PSI	2	10 FT/15 FT
2		53843145	HOSE-1/4X30-4 FS JIC 3000 PSI	1	10 FT/15 FT
3		53843239	HOSE-1/4X26 4FS JIC 3000 PSII	1	10 FT/15 FT
4		53843559	HOSE-1/4X32 4FS JIC 3000 PSI	2	10 FT/15 FT
5		159999001	HOSE-HYD-.38X59-6FSJ-ST/90-3000PSI	2	10 FT/15 FT
6		53843195	HOSE-1/4X16 4FS JIC 3000 PSI	2	10 FT/15 FT
7		296286537	HOSE - 1/4 X 166 4FS ST/90 JIC 3000 PSI	2	10 FT
		296280998	HOSE - HYD .25X192 4FSJ ST/90 3000 PSI	2	15 FT

Rod Loader Fig 12-7

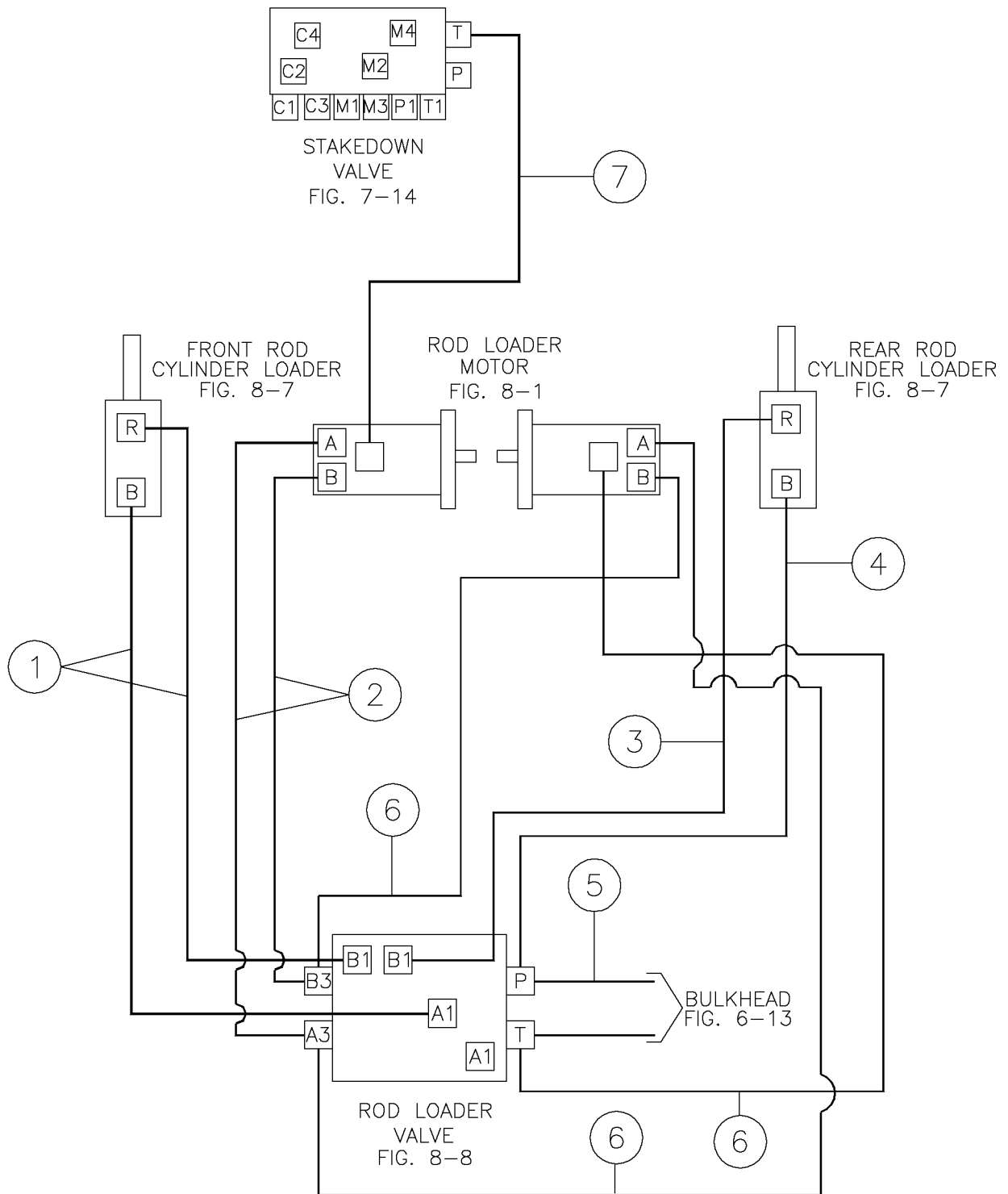

## Rod Loader Fig 12-7

REF. NO.	*	PART NO.	DESCRIPTION	QTY.	REMARKS
1		296284022	HOSE-3/8X128 6FS JIC 3000 PSI	2	15 FT
		296286524	HOSE - 3/8 X 98 6FS JIC 3000 PSI	2	10 FT
2		296284023	HOSE-3/8 X 119 6FS JIC 3000 PSI	2	15 FT
		296286523	HOSE - 3/8 X 96 6FS ST/90 JIC 3000 PSI	2	10 FT
3		296284024	HOSE-3/8 X 98 6FS JIC ST/90 3000 PSI	1	15 FT
		296286521	HOSE - 3/8 X 54 6FS ST/90 JIC 3000 PSI	1	10 FT
4		278843001	HOSE-3/8X92 6FSJIC ST/90 M3K	1	15 FT
		260837001	HOSE-HYD-.38X44-6FSJ-ST/90-3000PSI-100R17-M3KMTF	1	10 FT
5		257527001	HOSE-HYD 3/8 X 20 6FS JIC ST/90	2	10 FT/15 FT
6		261353001	HOSE-HYD-.38X60--6FSJ-ST/90-3000PSI-M3K	3	15 FT
		151015001	HOSE - 3/8 X 30 6FS JIC X6 FS JIC 90'	3	10 FT
7		296284027	HOSE-1/4 X 51 4FS JIC 3000 PSI	1	10 FT/15 FT

Water System-50 GPM FMC Fig 12-8

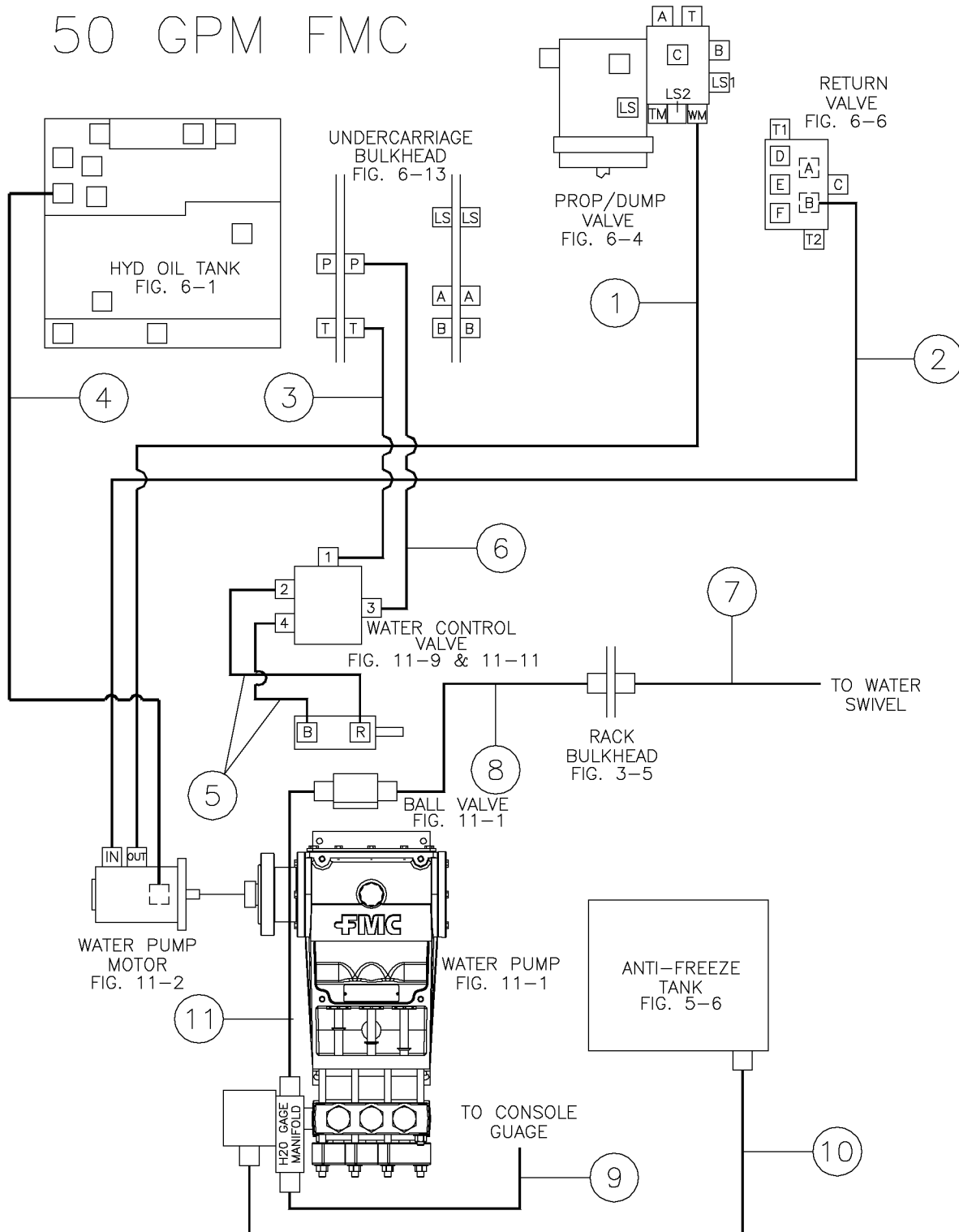



## Water System-50 GPM FMC Fig 12-8

REF. NO.	*	PART NO.	DESCRIPTION	QTY.	REMARKS
1		296280935	HOSE-.75X147 12FS JIC ST/ST 3000 PSI	1	15 FT
		275212001	HOSE-3/4X100 12FSJIC ST/ST M3K	1	10 FT
2		296280955	HOSE-.75X145 12FS JIC ST/ST 3000 PSI	1	15 FT
		53845033	HOSE-3/4X96 12FS JIC 100R4	1	10 FT
3		296284042	HOSE-3/8X71 6FS JIC ST/90 30000 PSI	1	15 FT
		57940477	HOSE-3/8X38 6FSJICST/6FSJC90	1	10 FT
4		296258371	HOSE - .25 X 144 4FS JIC ST/ST M3K	1	15 FT
		53843203	HOSE-1/4X106 4FS JIC 3000 PSI	1	10 FT
5		53843577	HOSE-1/4X16 4FSJICST/4FSJIC90D	2	15 FT
6		159751001	HOSE - 3/8 X 68 6FS JIC ST/90 3000# M3K	1	15 FT
		57940477	HOSE-3/8X38 6FSJICST/6FSJC90	1	10 FT
7		296280946	HOSE-1.00X222 16FS ST/45 JIC 3000 PSI	1	15 FT
		296286532	HOSE - 1.00 X 191 16FS ST/45 JIC 3000 PS	1	10 FT
8		296280945	HOSE-1.00X58 16FS JIC ST/90 3000 PSI	1	15 FT
		296280240	HOSE-1.0X31.5 16FS ST/45 JIC PSI 3000	1	10 FT
9		296280948	HOSE - MICRO	1	10 FT/15 FT
10		296280944	HOSE-3/4X70 12FS JIC ST/45 3000 PSI	1	10 FT/15 FT
11		296280216	HOSE-1.0X32 16FSJICST/90 3000	1	10 FT/15 FT

Water System- 50 GPM Aplex Fig 12-9

# 50 GPM APLEX

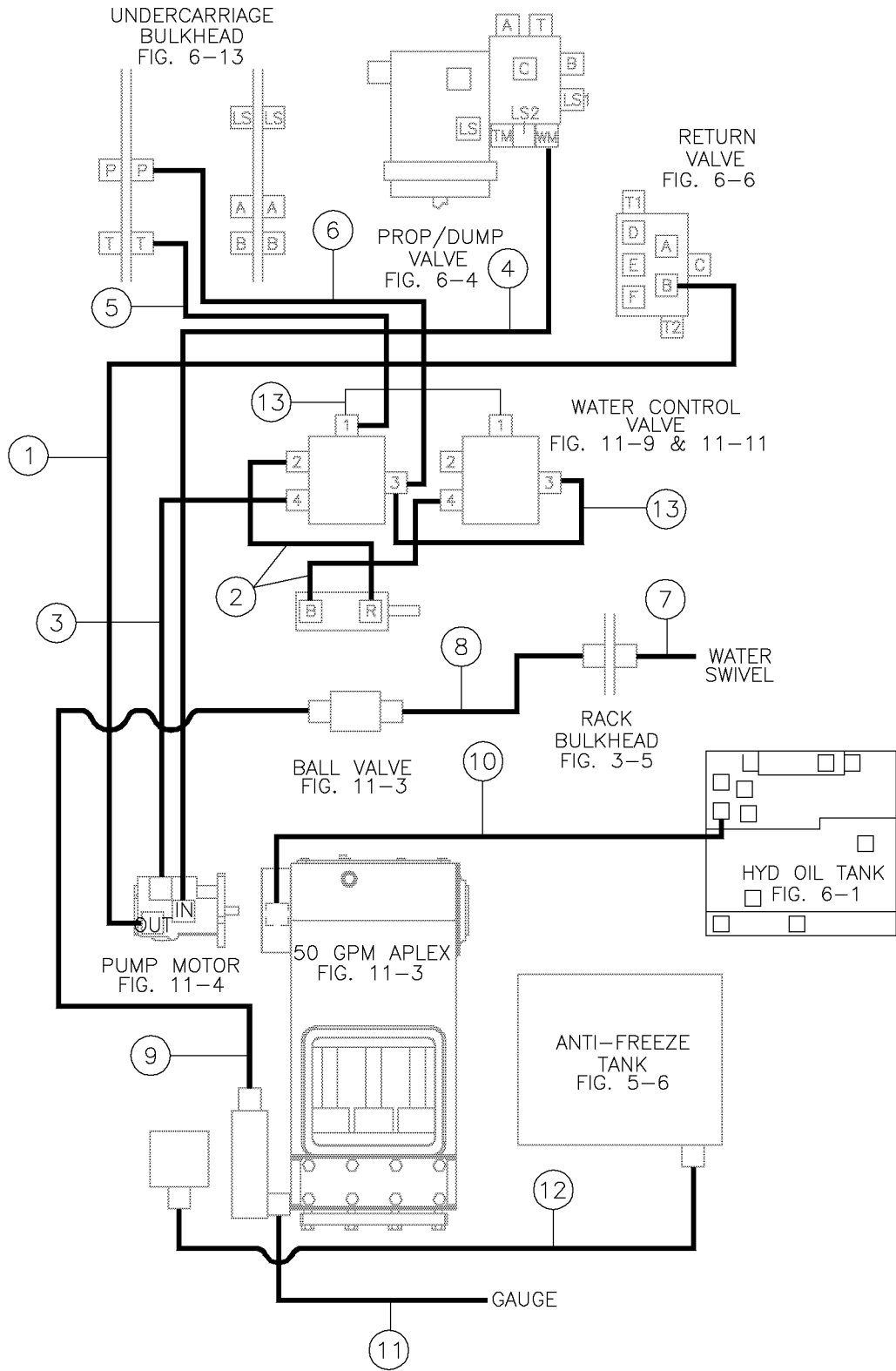

## Water System- 50 GPM Aplex Fig 12-9

REF. NO.	*	PART NO.	DESCRIPTION	QTY.	REMARKS
1		296280244	HOSE-3/4 X 126 12FS ST/ST PSI 3000	1	10 FT
		296280955	HOSE-.75X145 12FS JIC ST/ST 3000 PSI	1	15 FT
2		53843577	HOSE-1/4X16 4FSJICST/4FSJIC90D	2	10 FT/15 FT
3		53843145	HOSE-1/4X30-4 FS JIC 3000 PSI	1	10 FT/15 FT
4		296280245	HOSE- 3/4X130 12FS ST/ST PSI 3000	1	10 FT
		296280935	HOSE-.75X147 12FS JIC ST/ST 3000 PSI	1	15 FT
5		296284042	HOSE-3/8X71 6FS JIC ST/90 30000 PSI	1	10 FT/15 FT
6		159751001	HOSE - 3/8 X 68 6FS JIC ST/90 3000# M3K	1	10 FT/15 FT
7		296286532	HOSE - 1.00 X 191 16FS ST/45 JIC 3000 PS	1	10 FT
		296280946	HOSE-1.00X222 16FS ST/45 JIC 3000 PSI	1	15 FT
8		296286572	HOSE - 1.00 X 31.5 16FS JIC ST/90 3000 P	1	10 FT
		296280945	HOSE-1.00X58 16FS JIC ST/90 3000 PSI	1	15 FT
9		240748001	HOSE-3/4X63 12FSX12FS 3000 PSI	1	10 FT/15 FT
10		53843199	HOSE-1/4X118 4FS JIC 3000 PSI	1	10 FT/15 FT
11		296280948	HOSE - MICRO	1	10 FT/15 FT
12		296280216	HOSE-1.0X32 16FSJICST/90 3000	1	10 FT/15 FT
13		57940719	HOSE-3/8X21 6FSJICST/45D3000#	2	10 FT/15 FT

Water System- 70 GPM Aplex Fig 12-10

70 GPM APLEX

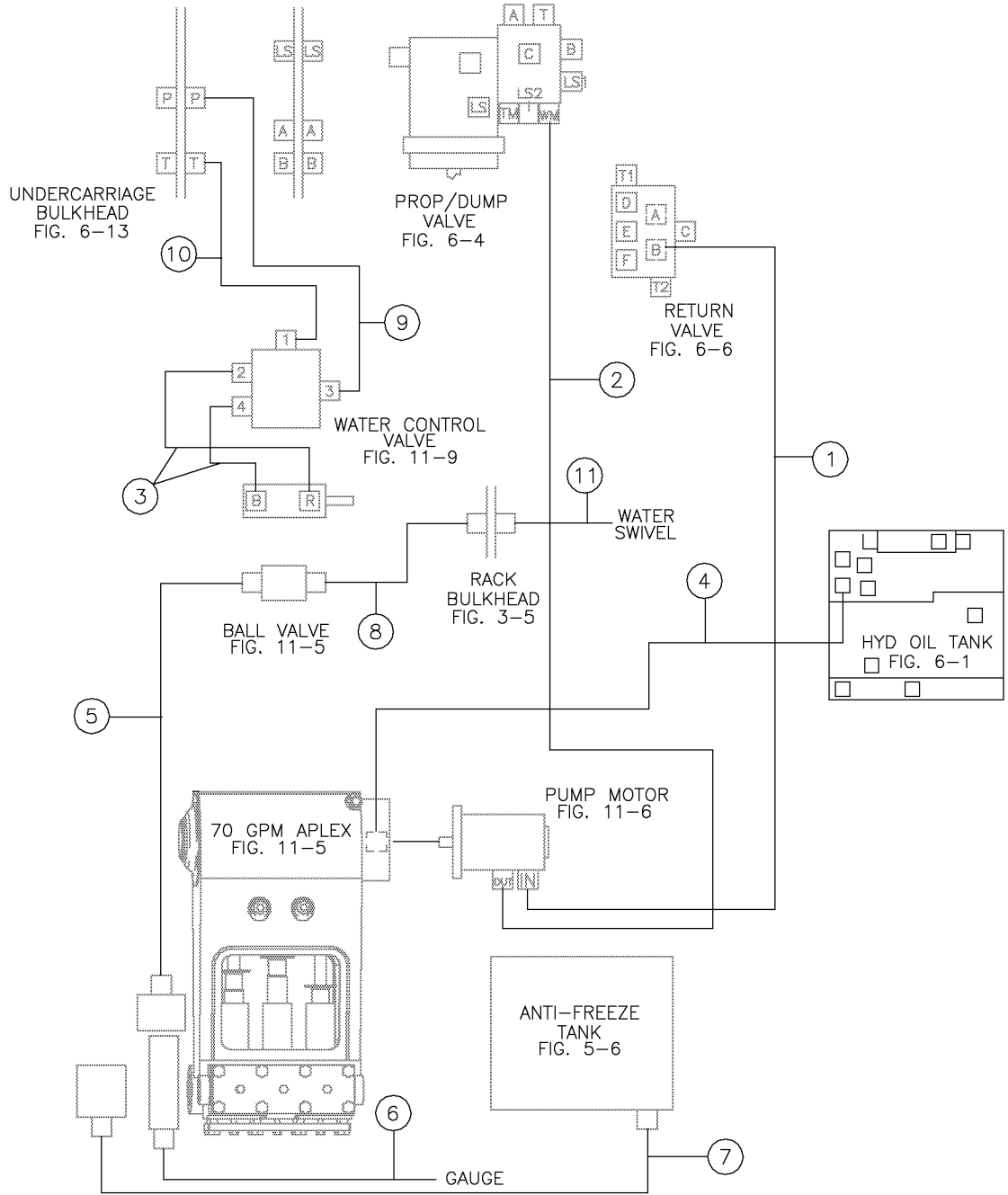

## Water System- 70 GPM Apex Fig 12-10

REF. NO.	*	PART NO.	DESCRIPTION	QTY.	REMARKS
1		296286539	HOSE - 3/4 X 119 12 FS ST/ST JIC 3000 PS	1	15 FT
		53845033	HOSE-3/4X96 12FS JIC 100R4	1	10 FT
2		296286540	HOSE- 3/4 X 121 12 FS ST/ST JIC 3000 PSI	1	15 FT
		275212001	HOSE-3/4X100 12FSJIC ST/ST M3K	1	10 FT
3		53843577	HOSE-1/4X16 4FSJICST/4FSJIC90D	2	10 FT/15 FT
4		53843203	HOSE-1/4X106 4FS JIC 3000 PSI	1	10 FT
		53843243	HOSE-1/4X130 4FS JIC 3000 PSI	1	15 FT
5		296280216	HOSE-1.0X32 16FSJICST/90 3000	1	10 FT/15 FT
6		296280948	HOSE - MICRO	1	10 FT/15 FT
7		296280944	HOSE-3/4X70 12FS JIC ST/45 3000 PSI	1	10 FT/15 FT
8		296286572	HOSE - 1.00 X 31.5 16FS JIC ST/90 3000 P	1	10 FT
		296280945	HOSE-1.00X58 16FS JIC ST/90 3000 PSI	1	15 FT
9		57940477	HOSE-3/8X38 6FSJICST/6FSJC90	1	10 FT
		159751001	HOSE - 3/8 X 68 6FS JIC ST/90 3000# M3K	1	15 FT
10		57940477	HOSE-3/8X38 6FSJICST/6FSJC90	1	10 FT
		296284042	HOSE-3/8X71 6FS JIC ST/90 30000 PSI	1	15 FT
11		296286532	HOSE - 1.00 X 191 16FS ST/45 JIC 3000 PS	1	10 FT
		296280946	HOSE-1.00X222 16FS ST/45 JIC 3000 PSI	1	15 FT



## Bucket Auto Greaser Fig 12-11

REF. NO.	*	PART NO.	DESCRIPTION	QTY.	REMARKS
1		57940319	HOSE-3/8X67 6FS JIC ST 3000	2	
2		53843383	*HOSE-1/4X18 4FS JIC 3000 PSI	2	
3		53843547	HOSE-1/4X21 4FS JIC 3000 PSI	1	

Cab Fig 12-12

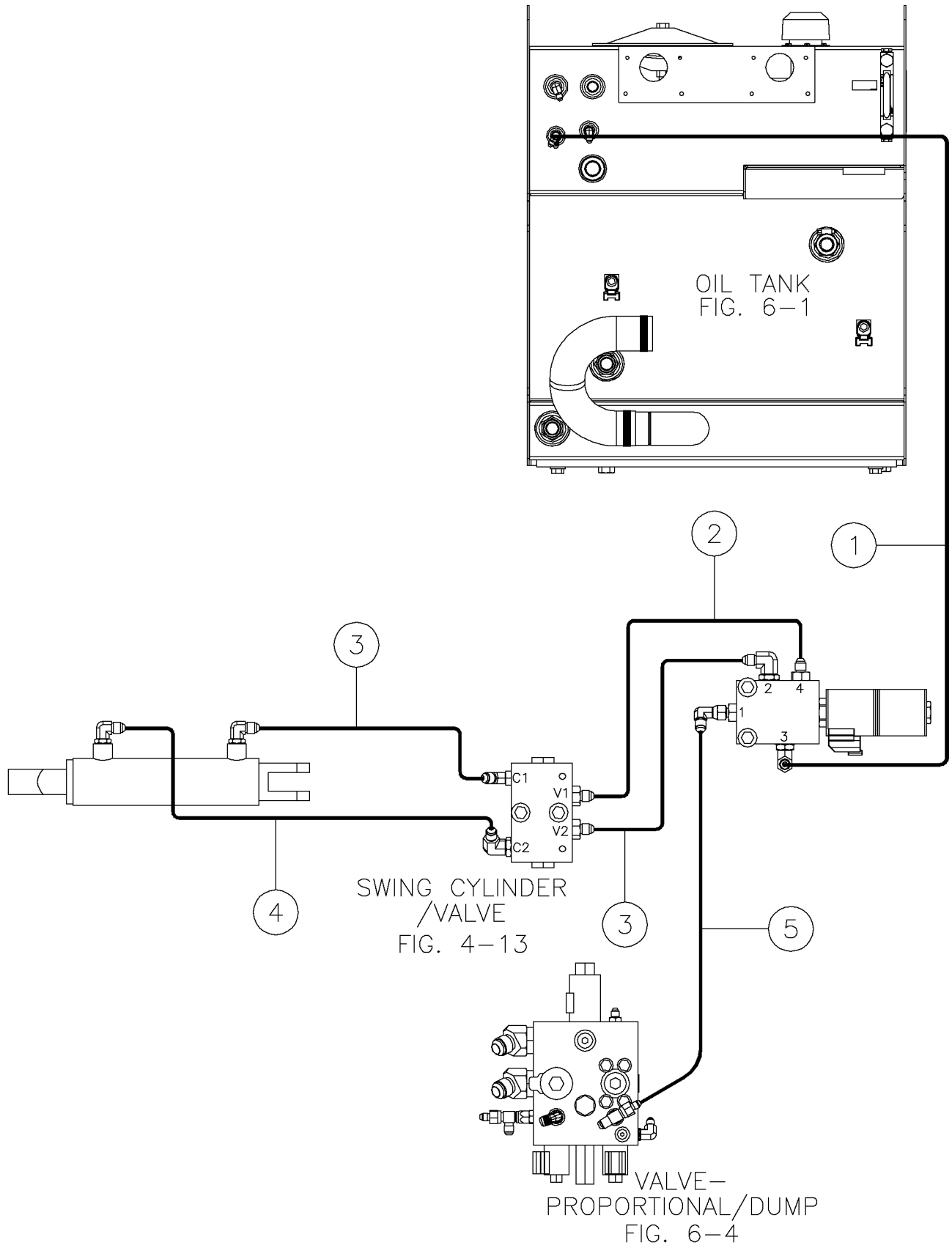



## Cab Fig 12-12

REF. NO.	*	PART NO.	DESCRIPTION	QTY.	REMARKS
1		232124045	HOSE-1/4 X 54 FSJIC X FSJIC 90	1	
2		296303315	HOSE - 1/4 X 13 4FS JIC 3000PSI	1	
3		53843795	HOSE-1/4"-9 XCX 4FS 3000 PSI	2	
4		53843601	HOSE-1/4X17 4FS JIC 3000 PSI	1	
5		235942001	HOSE-1/4X60 4FSJICST/4FS903000	1	

**NOTES:** \_\_\_\_\_

\_\_\_\_\_

\_\_\_\_\_

\_\_\_\_\_

\_\_\_\_\_

\_\_\_\_\_

\_\_\_\_\_

\_\_\_\_\_

\_\_\_\_\_

\_\_\_\_\_

\_\_\_\_\_

\_\_\_\_\_

\_\_\_\_\_

\_\_\_\_\_

\_\_\_\_\_

\_\_\_\_\_

\_\_\_\_\_

\_\_\_\_\_

\_\_\_\_\_

\_\_\_\_\_

\_\_\_\_\_



No part of this manual may be reproduced in any form or by any means, electronic or mechanical, including photocopying, recording, or by any information storage and retrieval systems, without the express written consent of Vermeer Corporation.

**Copyright © 2009 Vermeer Corporation**  
**All rights reserved.**  
**Vermeer Corporation**  
**1210 Vermeer Road East, P.O. Box 200**  
**Pella, Iowa 50219-0200, USA**